SINGLE OR MULTI CELL LED DRIVER SOLUTION

DESCRIPTION

The ZXSC300 is a single or multi cell LED driver designed for applications where step-up voltage conversion from very low input voltages is required. These applications mainly operate from single 1.5V or 1.2V battery cells. The circuit generates constant current pulses that are ideal for driving single or multiple LED's over a wide range of operating voltages.

The ZXSC300 is a PFM controller IC that drives an external Zetex switching transistor with a very low saturation resistance. These transistors are the best switching devices available for this type of switching conversion enabling high efficiency conversion with input voltages below 1 volt. The drive output of the ZXSC controller generates a dynamic drive signal for the switching transistor.

The circuit can start up under full load and operates down to an input voltage of 0.8 volts. The solution configuration ensures optimum efficiency over a wide range of load currents, several circuit configurations are possible depending on battery life versus brightness considerations.

The ZXSC300 is offered in the SOT23-5 package which, when combined with a SOT23 switching transistor, generates a high efficiency small size circuit solution. The IC and discrete combination offers the ultimate cost vs performance solution for single cell LED driving applications.

FEATURES

- 94% efficiency
- Minimum operating input voltage 0.8V
- Fixed output current
- Low saturation voltage switching transistor
- SOT23-5 package

APPLICATIONS

- LED flashlights and torches
- LED backlights
- White LED driving
- Multiple LED driving
- Solar Equipment

TYPICAL APPLICATION CIRCUIT

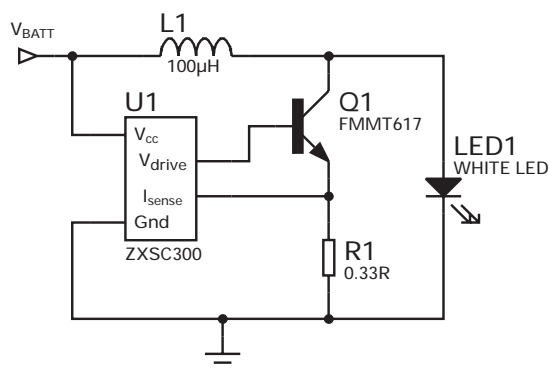

ORDERING INFORMATION

DEVICE	Reel	Tapewidth	Quantity per reel
ZXSC300E5TA	7"	8mm	3,000

DEVICE MARKING C300

Package SOT23-5

ZXSC300

ABSOLUTE MAXIMUM RATING

Supply Voltage	-0.3 to 10V	Operating Temperature	-40 to 85°C
Maximum Voltage Other Pins	-0.3 to V _{CC} +0.3V	Storage Temperature	-55 to 150°C
Power Dissipation	450mW		

ELECTRICAL CHARACTERISTICS: Test conditions unless otherwise stated: V_{CC}=1.5V, T_{AMB}=25°C

SYMBOL	PARAMETER	CONDITIONS	MIN.	TYP.	MAX.	UNITS
η	Efficiency ¹				94	%
V _{CC}	Recommended supply voltage range		0.8		8	V
V _{CC(min)}	Minimum startup and operating voltage	I _{DRIVE} = -600 μ A, V _{DRIVE} = 0.7V I _{DRIVE} = -600 μ A, V _{DRIVE} = 0.7V, T _{AMB} = -10°C ³		0.8 0.9	0.92	V
I _Q	Quiescent current ²			0.2		mA
I _{VDRIVE}	Base drive current	V _{DRIVE} = 0.7V, V _{ISENSE} = 0V	1.5		3.6	mA
I _{CC}	Supply current ³	V _{DRIVE} = 0.7V, V _{ISENSE} = 0V	2		4	mA
V _{VDRIVE(high)}	High level drive voltage	V _{ISENSE} = 0V, I _{VDRIVE} = -0.5mA	V _{CC} -0.3		V _{CC}	V
V _{VDRIVE(low)}	Low level drive voltage	V _{ISENSE} = 50mV, I _{VDRIVE} = 5mA	0		0.2	V
V _{ISENSE (threshold)}	Output current reference voltage		14	19	24	mV
T _{CVISENSE}	I _{SENSE} voltage temp co. ²			0.4		%/°C
I _{ISENSE}	I _{SENSE} input current	V _{ISENSE} = 0V	0	-30	-65	μ A
T _{DRV}	Discharge pulse width		1.2	1.7	3.2	μ s

OPERATING CONDITIONS

SYMBOL	PARAMETER	CONDITIONS	MIN.	TYP.	MAX.	UNITS
F _{OSC}	Recommended operating frequency ⁴				200	kHz

¹ Application dependent, see reference designs.

² These parameters guaranteed by design and characterisation

³ Total supply current = I_Q + I_{VDRIVE}, see typical characteristics

⁴ Operating frequency is application circuit dependent. See applications section.

ZXSC300

FMMT617

For the circuits described in the applications section, Zetex FMMT617 is the recommended pass transistor. The following indicates outline data for the transistor, more detailed information can be found in the Zetex surface mount data book or at www.zetex.com

ELECTRICAL CHARACTERISTICS (at $T_A = 25^\circ\text{C}$ unless otherwise stated).

PARAMETER	SYMBOL	MIN.	TYP.	MAX.	UNIT	CONDITIONS
Collector-Emitter Saturation Voltage	$V_{CE(sat)}$		8	14	mV	$I_C=0.1A, I_B=10mA^*$ $I_C=1A, I_B=10mA^*$ $I_C=3A, I_B=40mA^*$
			70	100	mV	
			150	200	mV	
Collector-Emitter Breakdown Voltage	$V_{(BR)CEO}$	15	18		V	$I_C=10mA^*$

*Measured under pulsed conditions. Pulse width=300 μ s. Duty cycle \leq 2%

ZHCS1000

For the circuits described in the applications section Zetex ZHCS1000 is the recommended Schottky diode. The following indicates outline data for the diode, more detailed information is available at www.zetex.com

ELECTRICAL CHARACTERISTICS (at $T_{amb} = 25^\circ\text{C}$ unless otherwise stated).

PARAMETER	SYMBOL	MIN.	TYP.	MAX.	UNIT	CONDITIONS
Forward Voltage	V_F			400	mV	$I_F=500mA$ $I_F=1A$
				500	mV	
Reverse Current	I_R		50	100	μ A	$V_R=30V$
Reverse Recovery Time	t_{rr}		12		ns	Switched from $I_F = 500mA$ to $I_R = 500mA$. Measured at $I_R=50mA$

*Measured under pulsed conditions. Pulse width=300 μ s. Duty cycle \leq 2%

ZXSC300

TYPICAL CHARACTERISTICS

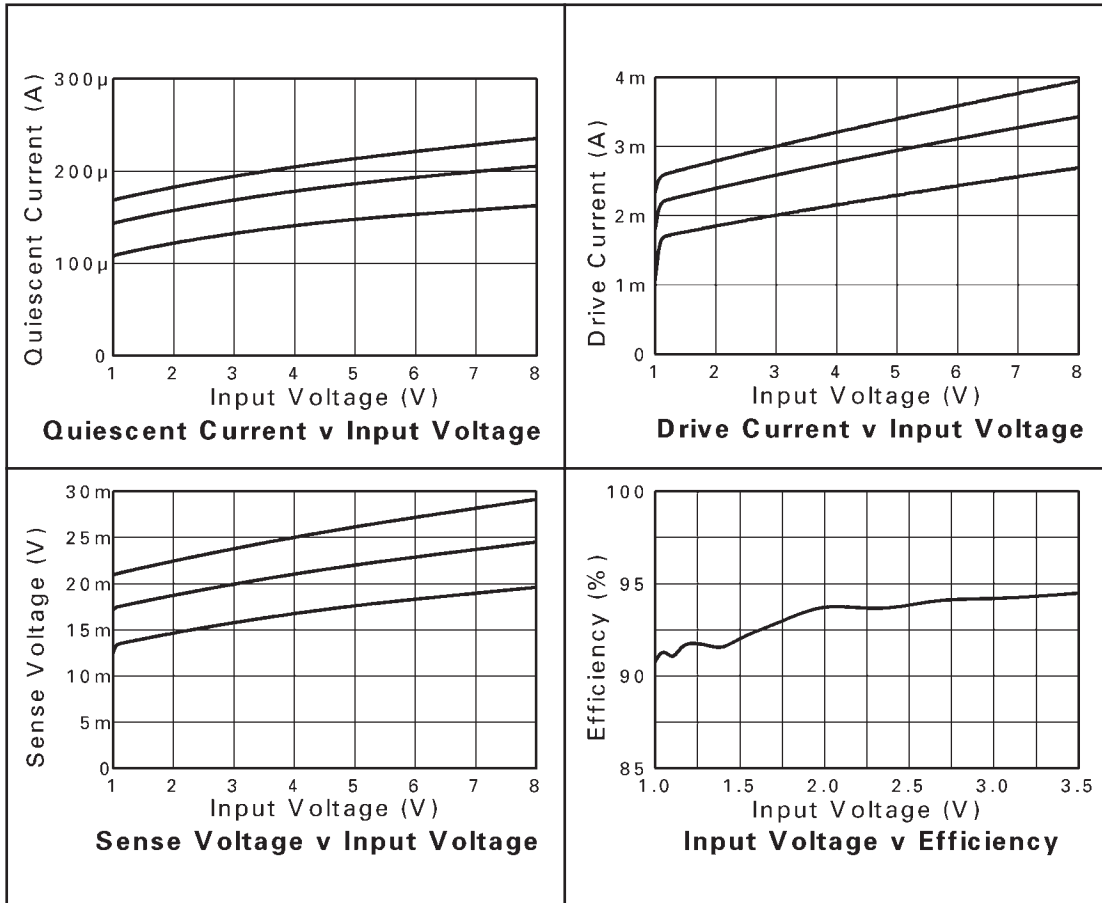

ZXSC300

DEVICE DESCRIPTION

The ZXSC300 is PFM, controller IC which, when combined with a high performance external transistor, enables the production of a high efficiency boost converter for use in single cell LED driving applications. A block diagram is shown for the ZXSC300 in Figure 1.

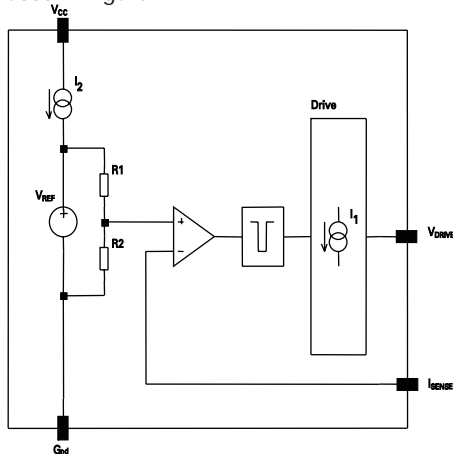
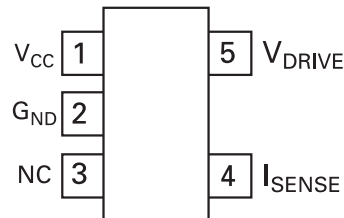

Figure 1 ZXSC300 Block Diagram

With every on pulse the switching transistor is kept on until the voltage across the current-sense resistor exceeds the threshold of the I_{SENSE} input. The on-pulse length, and therefore the switching frequency, is determined by the programmed peak current, the input voltage and the input to output voltage differential. See applications section for details.

The Driver circuit supplies the external switching transistor with a fixed drive current. To maximise efficiency the external transistor switched quickly, typically being forced off within 30ns.

Pin out Diagram



The on chip comparator forces the driver circuit and therefore the external switching transistor off if the voltage at I_{SENSE} exceeds 19mV. This threshold is set by an internal reference circuit and divider.

The Voltage at I_{SENSE} is taken from a current sense resistor connected in series with the emitter of the switching transistor. A monostable following the output of the comparator forces the turn-off time of the output stage to be typically 1.7 μ s. This ensures that there is sufficient time to discharge the inductor coil before the next on period.

Pin Descriptions

Pin No.	Name	Description
1	V_{CC}	Supply voltage, generally Alkaline, NiMH or NiCd single cell
2	Gnd	Ground
3	N/C	Not connected
4	I_{SENSE}	Inductor current sense input. Internal threshold voltage set to 19mV. Connect external sense resistor
5	V_{DRIVE}	Drive output for external switching transistor. Connect to base of external switching transistor

ZXSC300

REFERENCE DESIGNS

Two typical LED driving applications are shown. Firstly a maximum brightness solution and secondly an optimised battery life solution.

Maximum brightness solution

This circuit provides a constant current output to the LED by rectifying the switching pulses. This ensures maximum LED brightness.

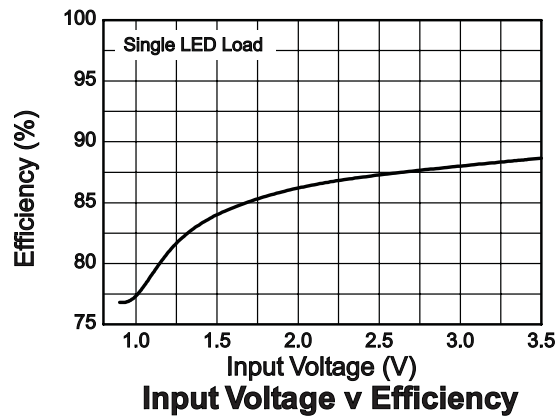
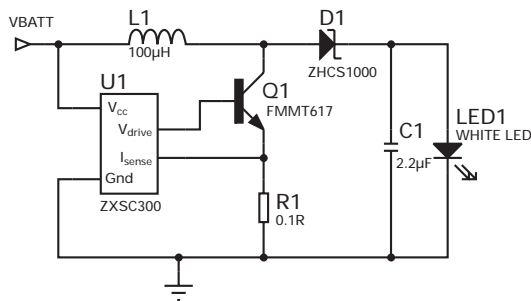

Material List

Ref	Value	Part Number	Manufacture	Comments
U1	N/A	ZXSC300E5	Zetex Plc	Single cell converter, SOT23-5
Q1	N/A	FM6T617	Zetex Plc	Low $V_{CE(sat)}$ NPN, SOT23
D1	1A	ZHCS1000	Zetex Plc	1A Schottky diode, SOT23
R1	100mW	Generic	Various	0805 Size
C1	2.2mF	Generic	Various	Low ESR ceramic capacitor
L1	100µH	DO1608P-104	Coilcraft	Surface mount inductor
LED1	5600mcd	NSPW500BS	Nichia	White LED

ZXSC300

Maximum battery life solution

To ensure optimum efficiency, and therefore maximum battery life, the LED is supplied with a pulsed current. Maximum efficiency is ensured with the removal of rectifier losses experienced in the maximum brightness solution.

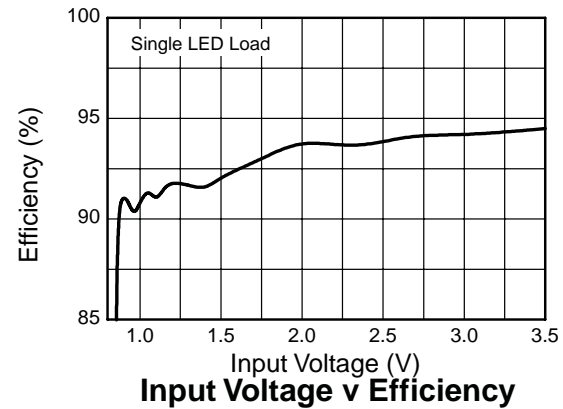
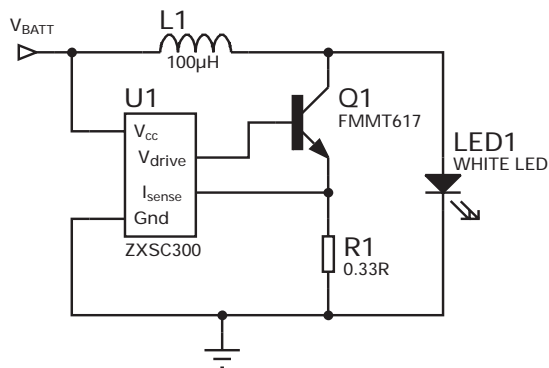

Materials list

Ref	Value	Part Number	Manufacture	Comments
U1	N/A	ZXSC300E5	Zetex Plc	Single cell converter, SOT23-5
Q1	N/A	FM617	Zetex Plc	Low $V_{CE(SAT)}$ NPN, SOT23
R1	330mW	Generic	Various	0805 Size
L1	100mH	DO1608P-104	Coilcraft	Surface mount inductor
LED1	5600mcd	NSPW500BS	Nichia	White LED

ZXSC300

APPLICATIONS INFORMATION

The following section is a design guide for optimum converter performance.

Switching transistor selection

The choice of switching transistor has a major impact on the converter efficiency. For optimum performance, a bipolar transistor with low $V_{CE(SAT)}$ and high gain is required.

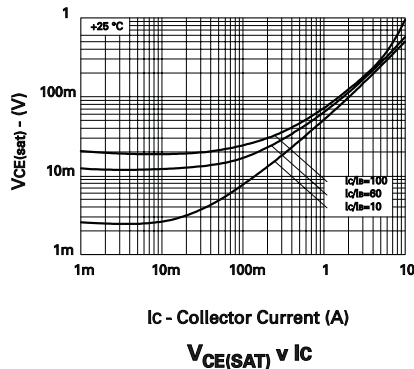

The Zetex FMMT617 is an ideal choice of transistor, having a low saturation voltage. A data sheet for the FMMT617 is available on Zetex web site or through your local Zetex sales office. Outline information is included in the characteristics section of this data sheet.

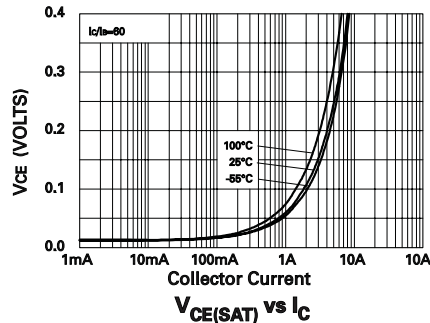

Schottky diode selection

For the maximum battery life solution a Schottky rectifier diode is required. As with the switching transistor the Schottky rectifier diode has a major impact on the converter efficiency. A Schottky diode with a low forward voltage and fast recovery time should be used for this application.

Inductor selection has a significant impact on the converter performance. For applications where efficiency is critical, an inductor with a series resistance of 500mΩ or less should be used.

The diode should be selected so that the maximum forward current is greater or equal to the maximum peak current in the inductor, and the maximum reverse voltage is greater or equal to the output voltage.

Peak current definition

The peak current rating is a design parameter whose value is dependent upon the overall application. For the high brightness reference designs, a peak current of was chosen to ensure that the converter could provide the required output power to the LED.

The Zetex ZHCS1000 meets these needs. Datasheets for the ZHCS Series are available on Zetex web site or through your local Zetex sales office. Outline information is included in the characteristics section of this data sheet.

In general, the I_{PK} value must be chosen to ensure that the switching transistor, Q1, is in full saturation with maximum output power conditions, assuming worst-case input voltage and transistor gain under all operating temperature extremes.

For the maximum brightness solution a pulsed current is supplied to the LED therefore a Schottky rectifier diode is not required.

Once I_{PK} is decided the value of R_{SENSE} can be determined by:

Inductor selection

$$R_{SENSE} = \frac{V_{ISENSE}}{I_{PK}}$$

where $V_{ISENSE} = 19mV$

The inductor value must be chosen to satisfy performance, cost and size requirements of the overall solution. For the reference designs we recommend an inductor value of 100uH with a core saturation current rating greater than the converter peak current value and low series resistance.



ZXSC300

Output Power Calculation

By making the above assumptions for inductance and peak current the output power can be determined by:

$$P_{OUT} = \frac{(V_{OUT} - V_{IN}) \times (I_{PK} + I_{MIN})}{2} \times \frac{T_{OFF}}{(T_{ON} + T_{OFF})}$$

Note: V_{OUT} = output voltage + Schottky rectifier voltage drop

where

$$T_{OFF} \cong 1.7\mu s \text{ (internally set by ZXSC300)}$$

and

$$T_{ON} = \frac{T_{OFF}(V_{OUT} - V_{IN})}{V_{IN}}$$

and

$$I_{MIN} = I_{PK} - \frac{(V_{OUT} - V_{IN}) \times T_{OFF}}{L}$$

Operating frequency can be derived by:

$$F = \frac{1}{(T_{ON} + T_{OFF})}$$

Capacitor selection

For pulsed operation, as in the maximum battery life solution, no capacitors are required at the output to the LED. For rectified operation, as in the maximum brightness solution, a small value ceramic capacitor is required, typically 2.2uF.

Generally an input capacitor is not required, but a small ceramic capacitor may be added to aid EMC, typically 470nF to 1uF.

Demonstration board

A demonstration board for the Maximum battery life solution, is available upon request. These can be obtained through your local Zetex office or through Zetex web pages. For all reference designs Gerber files and bill of materials can be supplied.

Layout of Maximum battery life solution

Top Copper

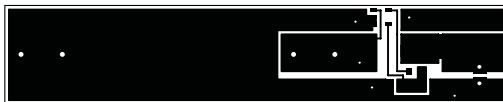

Drill Holes

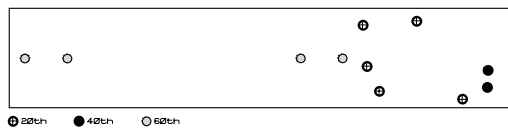

Bottom Copper



Silk Screen



ZXSC300

Notes:

ZXSC300

SUPPLIER LISTING

Manufacturer	EUROPE	ASIA	USA
Zetex	Zetex GmbH Germany	Zetex Asia Hong Kong	Zetex Inc
Tel:	(49) 894549490	(852) 2610 0611	(1) 631 543 7100
URL:	http://www.zetex.com		
AVX	AVX UK	AVX Asia Singapore	AVX USA
Tel:	(44) 1252 770000	(65) 6286 7555	(1) 843 448 9411
URL:	http://www.avxcorp.com		
Coilcraft	Coilcraft Europe UK		Coilcraft Inc
Tel:	(44) 1236 730595		(1) 847 639 6400
URL:	http://www.coilcraft.com		
Nichia Corporation	Nichia Europe B.V. The Netherlands	Nichia Corporation Japan	Nichia America Corporation
Tel:	(31) 20 5060900	(81) 3 3456 3784	Head Office (1) 717 285 2323 San Jose (1) 408 573 0933
URL:	http://www.nichia.co.jp		

ZXSC300

PACKAGE OUTLINE

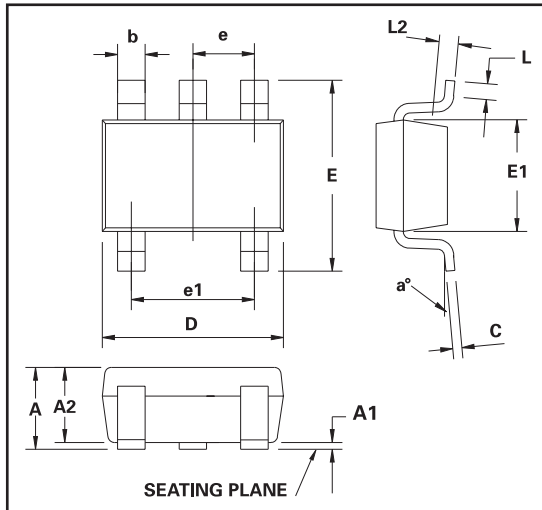

PACKAGE DIMENSIONS

DIM	Millimeters		Inches	
	MIN.	MAX.	MIN.	MAX.
A	0.90	1.45	0.0354	0.0570
A1	-	0.15	-	0.0059
A2	0.90	1.30	0.0354	0.0511
b	0.20	0.50	0.0078	0.0196
C	0.09	0.26	0.0035	0.0102
D	2.70	3.10	0.1062	0.1220
E	2.20	3.20	0.0866	0.1181
E1	1.30	1.80	0.0511	0.0708
e	0.95 REF		0.0374 REF	
e1	1.90 REF		0.0748 REF	
L	0.10	0.60	0.0039	0.0236
a	0°	30°	0°	30°

© Zetex plc 2003

Europe	Americas	Asia Pacific	Corporate Headquarters
Zetex GmbH Streitfeldstraße 19 D-81673 München Germany	Zetex Inc 700 Veterans Memorial Hwy Hauppauge, NY 11788 USA	Zetex (Asia) Ltd 3701-04 Metroplaza Tower 1 Hing Fong Road, Kwai Fong Hong Kong	Zetex plc Fields New Road, Chadderton Oldham, OL9 8NP United Kingdom
Telefon: (49) 89 45 49 49 0 Fax: (49) 89 45 49 49 49 europe.sales@zetex.com	Telephone: (1) 631 360 2222 Fax: (1) 631 360 8222 usa.sales@zetex.com	Telephone: (852) 26100 611 Fax: (852) 24250 494 asia.sales@zetex.com	Telephone (44) 161 622 4444 Fax: (44) 161 622 4446 hq@zetex.com

These offices are supported by agents and distributors in major countries world-wide.

This publication is issued to provide outline information only which (unless agreed by the Company in writing) may not be used, applied or reproduced for any purpose or form part of any order or contract or be regarded as a representation relating to the products or services concerned. The Company reserves the right to alter without notice the specification, design, price or conditions of supply of any product or service.

For the latest product information, log on to www.zetex.com



ISSUE 2 - FEBRUARY 2004