

UTC324

LINEAR INTEGRATED CIRCUIT

QUAD OPERATIONAL AMPLIFIERS

DESCRIPTION

The UTC324 consists of four independent, high gain internally frequency compensated operational amplifiers which were designed specifically to operate from a single power supply over a wide voltage range.

Operation from split power supplies is also possible so long as the difference between the two supplies 3 Volts to 32 volts.

Application areas include transducer amplifier, DC gain blocks and all the conventional OP amp circuits which now can be easily implemented in single power supply system.

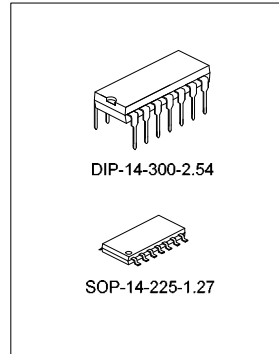

FEATURES

- *Internally frequency compensated for unity gain
- *Large DC voltage gain :100dB
- *Wide operating supply range($V_{CC}=3V\sim 32V$)
- *Input common-mode voltage includes ground
- *Large output voltage swing: From 0V to $V_{CC}-1.5V$
- *Power drain suitable for battery operation

ORDERING INFORMATION

Device	Package
UTC324D	DIP-14-300-2.54
UTC324E	SOP-14-225-1.27

BLOCK DIAGRAM

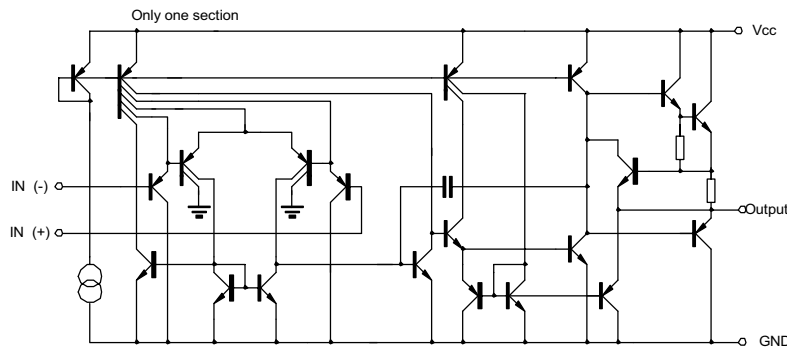

ABSOLUTE MAXIMUM RATINGS($T_a=25^{\circ}C$)

Characteristic	Symbol	Value	Unit
Supply Voltage	V_{CC}	± 18 or 36	V
Differential input voltage	$V_{i(diff)}$	32	V
Input Voltage	V_I	-0.3~32V	V
Power Dissipation	P_d	570	mW
Operating Temperature	T_{opr}	0 to +70	$^{\circ}C$

UTC324

LINEAR INTEGRATED CIRCUIT

Storage Temperature	Tstg	-65 to 150	°C
---------------------	------	------------	----

ELECTRICAL CHARACTERISTICS (Ta=25°C)

(Vcc=5.0V, All voltage referenced to GND unless otherwise specified)

Characteristic	Symbol	Test Condition	Min	Typ.	Max	Unit
Input offset voltage	V _{IO}	V _{CM} =0 to V _{CC} -1.5 V _{O(p)} =1.4V, R _S =0		1.5	7.0	mV
Input offset current	I _{IO}			3.0	50	nA
Input Bias current	I _b			40	250	nA
Input Common-mode voltage range	V _{I(R)}	V _{CC} =30V	0	V _{CC} -1.5		V
Supply Current	I _{CC}	R _L =∞, V _{CC} =30V		1.0	3	mA
		V _{CC} =5V		0.7	1.2	mA
Large signal Voltage Gain	G _V	V _{CC} =15V, R _L >2kΩ V _{O(p)} =1V to 11V	25	100		V/mV
		V _{CC} =30V, R _L =2kΩ	26			V
Output voltage Swing	V _(OH)	V _{CC} =30V, R _L =10kΩ	27	28		V
		V _{CC} =5, R _L >10kΩ		5	20	mV
Common-mode rejection Ratio	CMRR		65	75		dB
Power supply rejection Ratio	PSRR		65	100		dB
Channel Separation	CS	f=1kHz to 20kHz		5	20	mV
Short circuit to GND	I _{SC}			40	60	mA
Output current	I _{source}	V _{I(+)} =1V, V _{I(-)} =0 V _{CC} =15V, V _{O(p)} =2V	20	40		mA
	I _{sink}	V _{I(+)} =0V, V _{I(-)} =1V V _{CC} =15V, V _{O(p)} =2V	10	13		mA
		V _{I(+)} =1V, V _{I(-)} =0 V _{CC} =15V, V _{O(p)} =200V	12	45		μA
Differential input voltage	V _{I(diff)}				V _{CC}	V

PIN CONFIGURATION

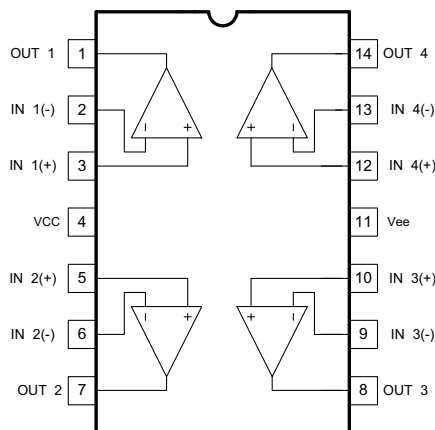

TYPICAL CHARACTERISTICS PERFORMANCE

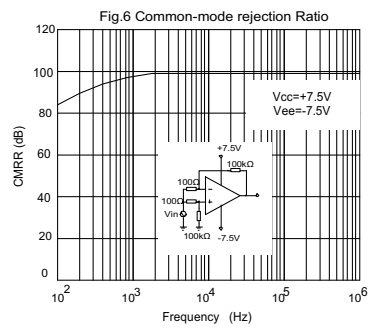
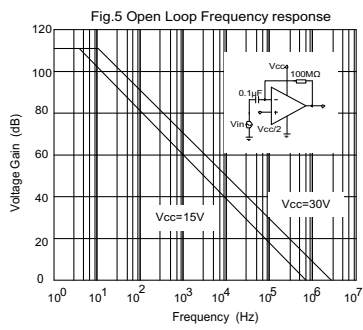
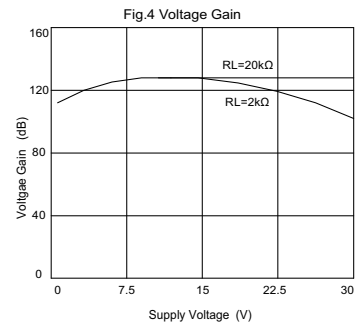
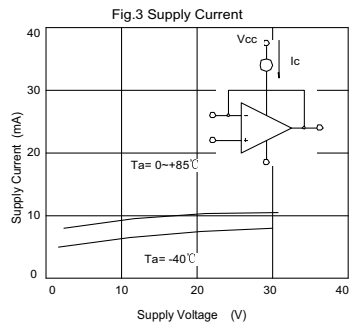
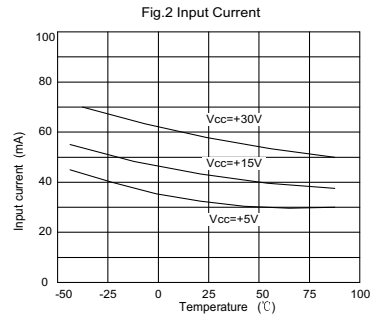
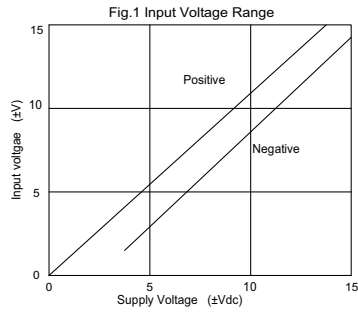

Fig.7

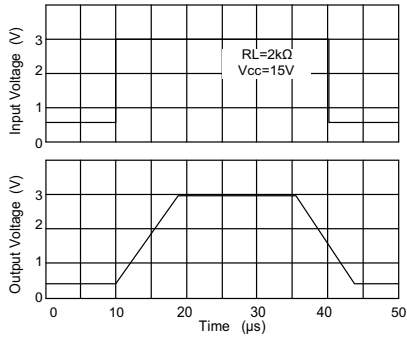

Fig.8 voltage Follower pulse response (small signal)

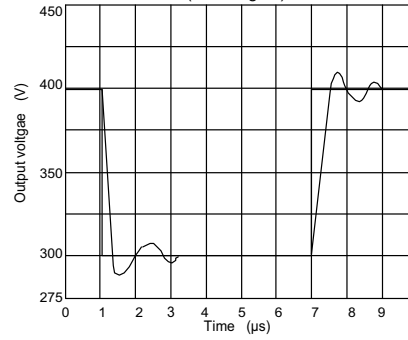

Fig.9 Large signal Frequency Response

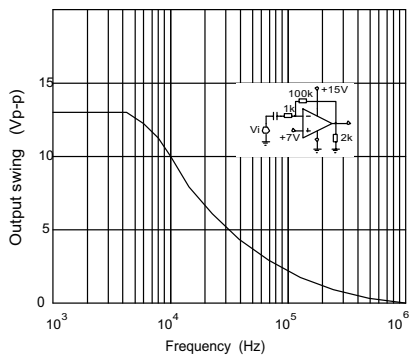

Fig.10 Output Characteristics current sourcing

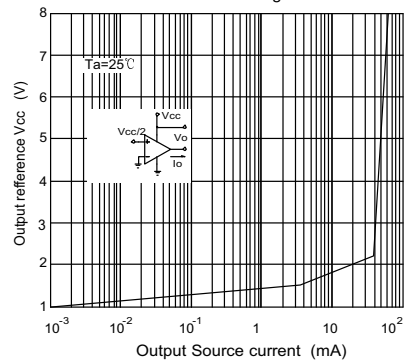

Fig.11 Output Characteristics Current sinking

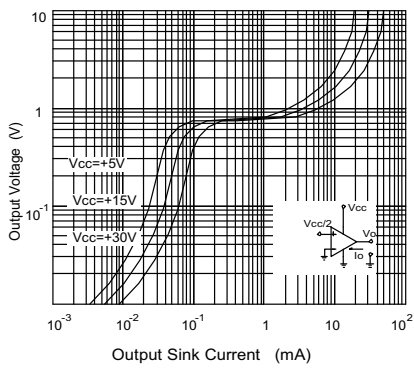
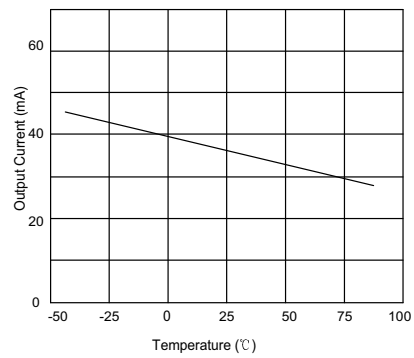

Fig.12 Current Limiting



UTC324

LINEAR INTEGRATED CIRCUIT

PACKAGE OUTLINE

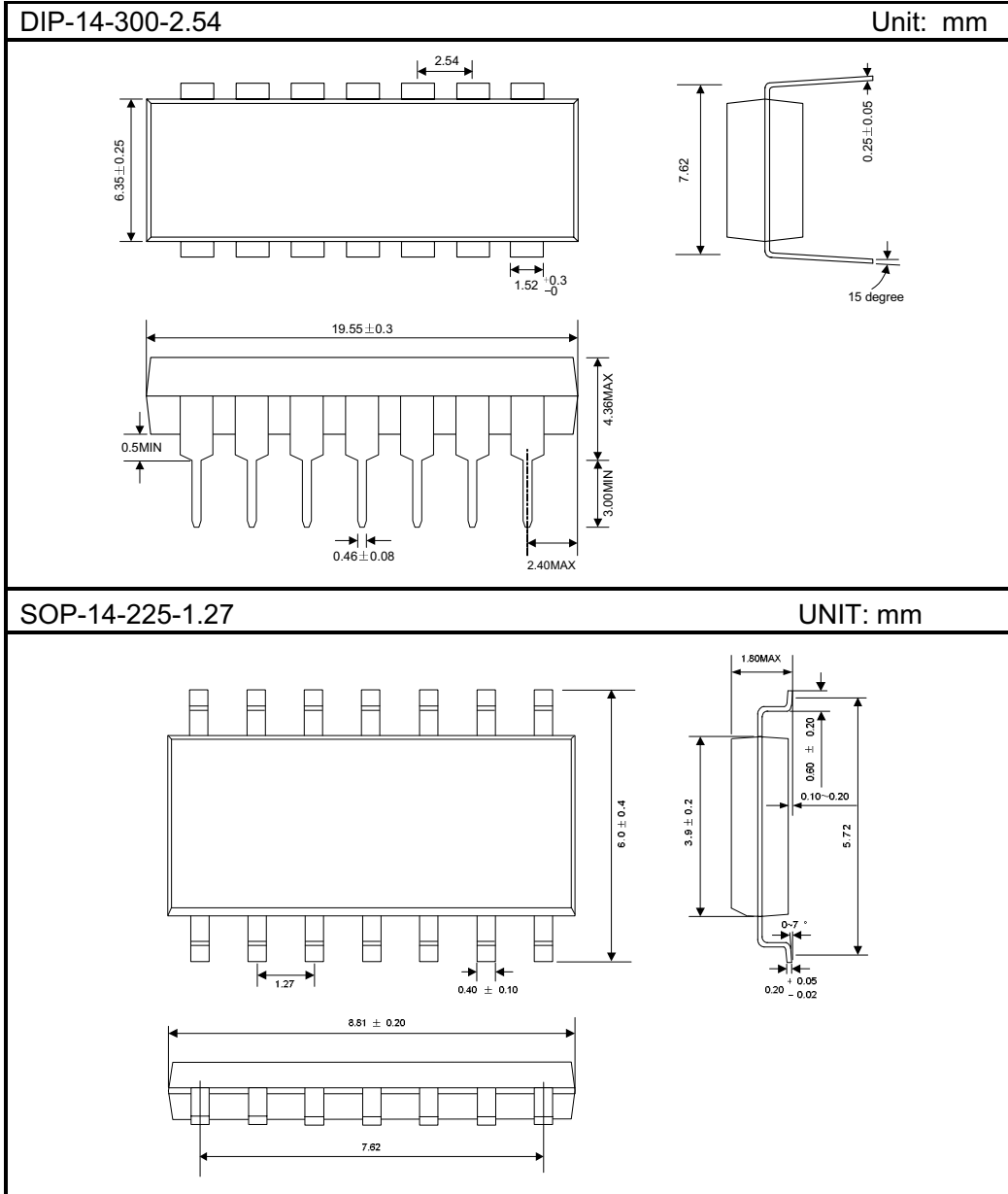

Attach

Revision History

Data	REV	Description	Page
	1.0	Original	
2003.10.15	1.1	Add "CHIP TOPOGRAPHY"	5
		Add "PAD COORDINATES"	5
2004.07.20	1.2	Add"SOP-14-225-1.27"	1
		Add"DIP-14-300-2.54、SOP-14-225-1.27"Package out line	5