

- **Overvoltage Protection and Lockout for 12 V, 5 V, 3.3 V**
- **Undervoltage Protection and Lockout for 5 V and 3.3 V**
- **Fault Protection Output With Open-Drain Output Stage**
- **Open-Drain Power Good Output Signal for Power Good Input, 3.3 V and 5 V**
- **Power Good Delay; 300-ms TPS3510, 150-ms TPS3511**
- **75-ms Delay for 5-V and 3.3-V Power Supply Short-Circuit Turnon Protection**
- **2.3-ms $\overline{\text{PSON}}$ Control to $\overline{\text{FPO}}$ Turnoff Delay**
- **38-ms $\overline{\text{PSON}}$ Control Debounce**
- **73- μs Width Noise Deglitches**
- **Wide Supply Voltage Range From 4 V to 15 V**

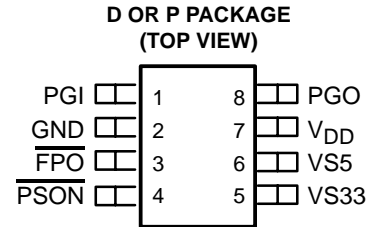

description

The TPS3510/1 is designed to minimize external components of personal-computer switching power supply systems. It provides protection circuits, power good indicator, fault protection output ($\overline{\text{FPO}}$) and $\overline{\text{PSON}}$ control.

Overvoltage protection (OVP) monitors 3.3 V, 5 V, and 12 V (12-V signal detects via V_{DD} pin). Undervoltage protection (UVP) monitors 3.3 V and 5 V. When an OV or UV condition is detected, the power good output (PGO) is set to low and $\overline{\text{FPO}}$ is latched high. $\overline{\text{PSON}}$ from low to high resets the protection latch. UVP function is enabled 75 ms after $\overline{\text{PSON}}$ is set low and debounced. Furthermore, there is a 2.3-ms delay (and an additional 38-ms debounce) at turnoff. There is no delay during turnon.

Power good feature monitors PGI, 3.3 V and 5 V and issues a power good signal when the output is ready.

The TPS3510/1 is characterized for operation from -40°C to 85°C .

typical application

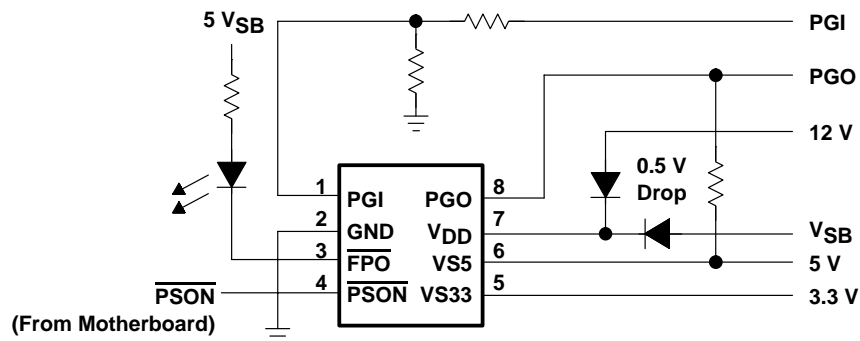

Please be aware that an important notice concerning availability, standard warranty, and use in critical applications of Texas Instruments semiconductor products and disclaimers thereto appears at the end of this data sheet.

PRODUCTION DATA information is current as of publication date. Products conform to specifications per the terms of Texas Instruments standard warranty. Production processing does not necessarily include testing of all parameters.

**TEXAS
INSTRUMENTS**

POST OFFICE BOX 655303 • DALLAS, TEXAS 75265

Copyright © 2002, Texas Instruments Incorporated

TPS3510,TPS3511 PC POWER SUPPLY SUPERVISORS

SLVS312A – JULY 2000 – REVISED DECEMBER 2002

FUNCTION TABLE

PGI	$\overline{\text{PSON}}$	UV CONDITION (3.3 V OR 5 V)	OV CONDITION (3.3 V, 5 V, OR 12 V)	$\overline{\text{FPO}}$	PGO
<0.95 V	L	no	no	L	L
<0.95 V	L	no	yes	H	L
<0.95 V	L	yes	no	L	L
0.95 V < PGI < 1.15 V	L	no	no	L	L
0.95 V < PGI < 1.15 V	L	no	yes	H	L
0.95 V < PGI < 1.15 V	L	yes	no	H	L
PGI > 1.15 V	L	no	no	L	H
PGI > 1.15 V	L	no	yes	H	L
PGI > 1.15 V	L	yes	no	H	L
x	H	x	x	H	L

x = don't care

$\overline{\text{FPO}}$ = L means: fault IS NOT latched

$\overline{\text{FPO}}$ = H means: fault IS latched

PGO = L means: fault

PGO = H means: NO fault

functional block diagram

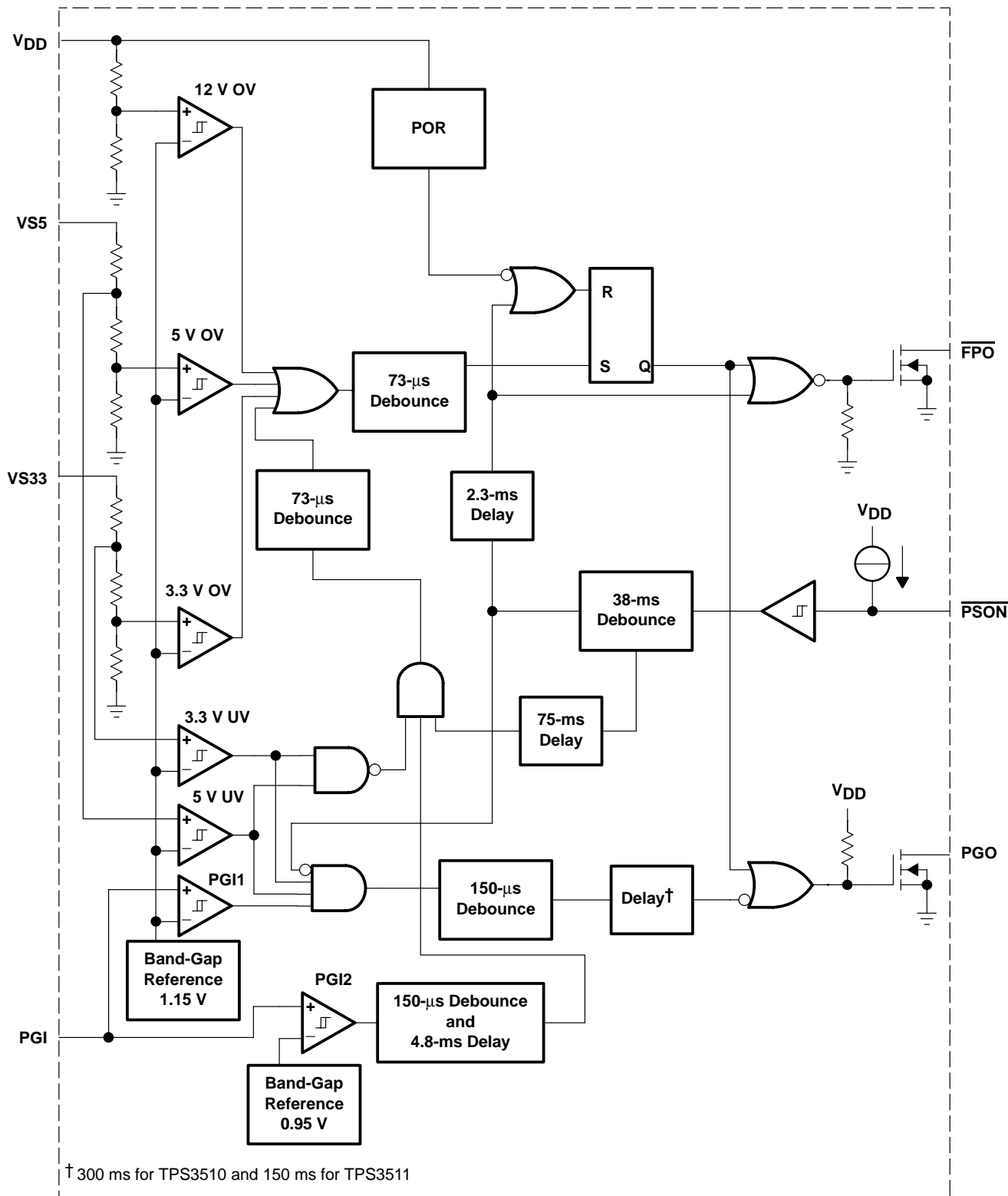

TPS3510,TPS3511 PC POWER SUPPLY SUPERVISORS

SLVS312A – JULY 2000 – REVISED DECEMBER 2002

timing diagram

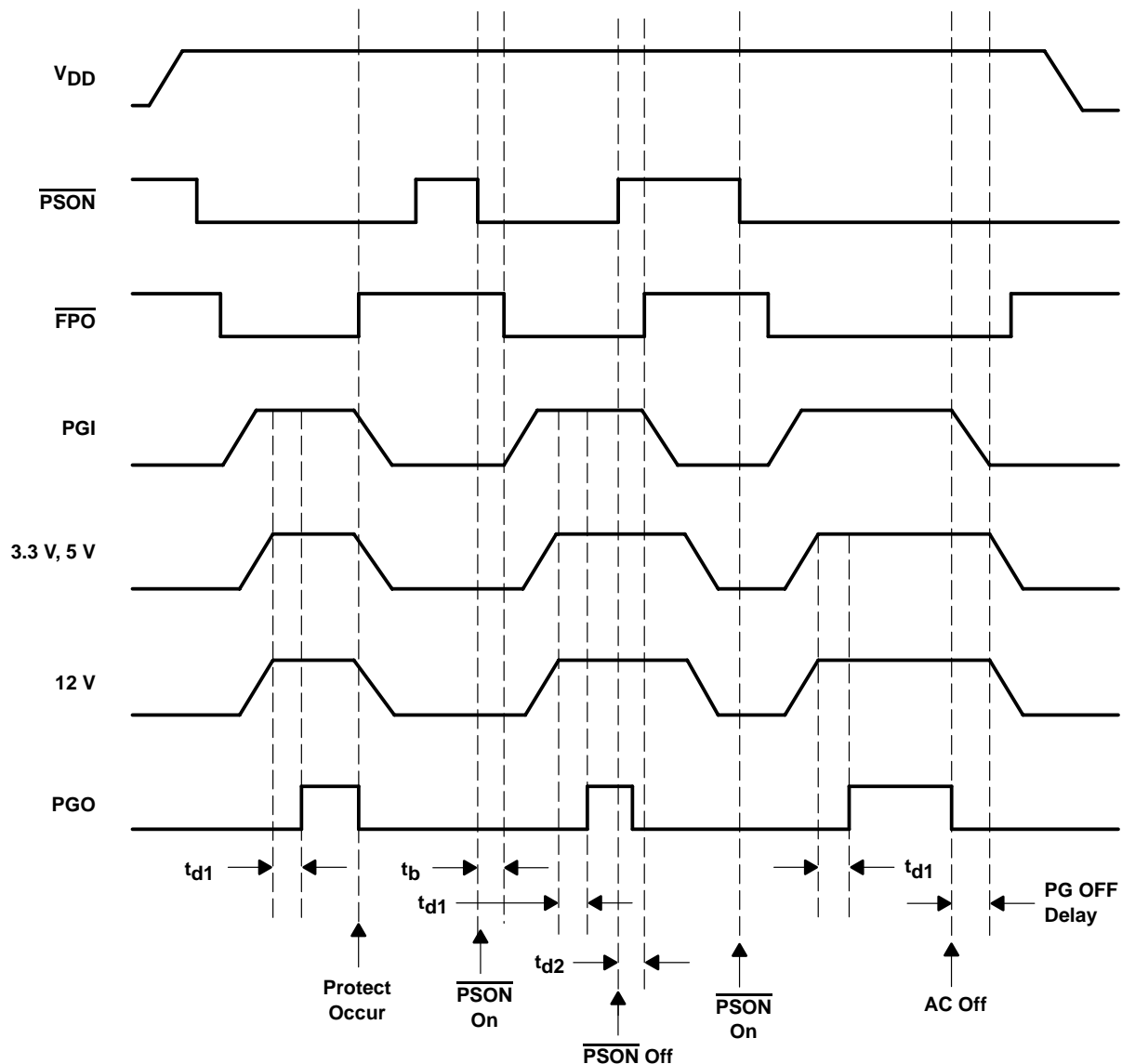

Terminal Functions

TERMINAL NAME	NO.	I/O	DESCRIPTION
$\overline{\text{FPO}}$	3	O	Inverted fault protection output, open drain output stage
GND	2		Ground
PGI	1	I	Power good input
PGO	8	O	Power good output, open drain output stage
$\overline{\text{PSON}}$	4	I	ON/OFF control
V_{DD}	7	I	Supply voltage/12 V overvoltage protection input pin
VS33	5	I	3.3 V over/undervoltage protection
VS5	6	I	5 V over/undervoltage protection



POST OFFICE BOX 655303 • DALLAS, TEXAS 75265

detailed description

power good and power good delay

A PC power supply is commonly designed to provide a power-good signal, which is defined by the computer manufacturers. PGO is a power-good signal and should be asserted high by the PC power supply to indicate that the 5-V and 3.3-V outputs are above the under-voltage threshold limit. At this time the converter should be able to provide enough power to ensure continuous operation within the specification. Conversely, when either the 5-V or the 3.3-V output voltages fall below the under-voltage threshold, or when ac power has been removed for a time sufficiently long so that power supply operation is no longer ensured, PGO should be de-asserted to a low state.

Figure 1 represents the timing characteristics of the power good (PGO), dc enable ($\overline{\text{PSON}}$), and the 5 V/3.3 V supply rails.

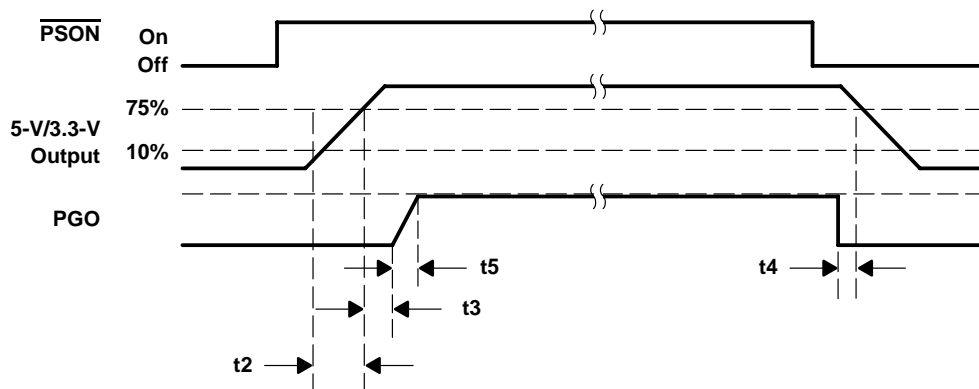

Figure 1. Timing of $\overline{\text{PSON}}$ and PGO

Although there is no requirement to meet specific timing parameters, the following signal timings are recommended:

$$2 \text{ ms} \leq t_2 \leq 20 \text{ ms}, 100 \text{ ms} < t_3 < 2000 \text{ ms}, t_4 > 1 \text{ ms}, t_5 \leq 10 \text{ ms}$$

Furthermore motherboards should be designed to comply with the previously recommended timing. If timings other than these are implemented or required, this information should be clearly specified.

The TPS3510/1 family of power-supply supervisors provides a power-good output (PGO) for the 3.3-V and 5-V supply voltage rails and a separate power-good input (PGI). An internal timer is used to generate a power-good delay. If the voltage signals at PGI, VS33, and VS5 rise above the under-voltage threshold, the open-drain power-good output (PGO) goes high after a delay of 150 ms or 300 ms. When the PGI voltage or either the 3.3-V and 5-V power rails drops below the under-voltage threshold, PGO is disabled immediately (after 150- μ s debounce).

power supply remote on/off ($\overline{\text{PSON}}$) and fault protect output ($\overline{\text{FPO}}$)

Since the latest personal computer generation focuses on easy turnon and power saving functions, the PC power supply requires two characteristics. One is a dc power supply remote on/off function, the other is standby voltage to achieve very low power consumption of the PC system. Thus the main power needs to be shut down.

The power supply remote on/off ($\overline{\text{PSON}}$) is an active low signal that turns on all of the main power rails including 3.3 V, 5 V, -5 V, 12 V, and -12 V power rails. When this signal is held high by the PC motherboard or left open circuited, the signal of the fault protect output ($\overline{\text{FPO}}$) also goes high. Thus, the main power rails should not deliver current and should be held at 0 V.

TPS3510,TPS3511 PC POWER SUPPLY SUPERVISORS

SLVS312A – JULY 2000 – REVISED DECEMBER 2002

power supply remote on/off ($\overline{\text{PSON}}$) and fault protect output ($\overline{\text{FPO}}$)(continued)

When the $\overline{\text{FPO}}$ signal is held high due to an occurring fault condition, the fault status is latched and the outputs of the main power rails should not deliver current but are held at 0 V. Toggling the power supply remote on/off ($\overline{\text{PSON}}$) from low to high resets the fault-protection latch. During this fault condition only the standby power is not affected.

When $\overline{\text{PSON}}$ goes from high to low or low to high, the 38-ms debounce block is active to avoid a glitch on the input that disables/enables the $\overline{\text{FPO}}$ output. During this period the under-voltage function is disabled for 75 ms to prevent turnon failure. At turnoff, there is an additional delay of 2.3 ms from $\overline{\text{PSON}}$ to $\overline{\text{FPO}}$.

Power should be delivered to the rails only if the $\overline{\text{PSON}}$ signal is held at ground potential, thus $\overline{\text{FPO}}$ is active-low. The $\overline{\text{FPO}}$ pin can be connected to 5 V (or up to 15 V) through a pullup resistor.

undervoltage protection

The TPS3510/1 provides under-voltage protection (UVP) for the 3.3-V and 5-V rails. When an undervoltage condition appears at either one of the 3.3-V (VS33) or 5-V (VS5) input pins for more than 146 μs , the $\overline{\text{FPO}}$ output goes high and PGO goes low. Also, this fault condition is latched until $\overline{\text{PSON}}$ is toggled from low to high or V_{DD} is removed.

The need for undervoltage protection is often overlooked in off-line switching power supply system design. But it is very important in battery-powered or hand-held equipment since the TTL or CMOS logic often results in malfunction.

In flyback or forward-type off-line switching power supplies, usually designed for low power, the overload protection design is very simple. Most of these types of power supplies are only sensing the input current for an overload condition. The trigger point needs to be set much higher than the maximum load in order to prevent false turnon.

However, this causes one critical problem. If the connected load is larger than the maximum allowable load but smaller than the trigger point, the system always becomes overheated with failure and damage occurring.

overvoltage protection

The overvoltage protection (OVP) of TPS3510/1 monitors 3.3 V, 5 V, and 12 V (12 V is sensed via the V_{DD} pin). When an overvoltage condition appears at one of the 3.3-V, 5-V, or 12-V input pins for more than 73 μs , the $\overline{\text{FPO}}$ output goes high and PGO goes low. Also, this fault condition is latched until $\overline{\text{PSON}}$ is toggled from low to high or V_{DD} is removed. During fault conditions, most power supplies have the potential to deliver higher output voltages than those normally specified or required. In unprotected equipment, it is possible for output voltages to be high enough to cause internal or external damage of the system. To protect the system under these abnormal conditions, it is common practice to provide overvoltage protection within the power supply.

Because TTL and CMOS circuits are very vulnerable to overvoltages, it is becoming industry standard to provide overvoltage protection on all 3.3-V and 5-V outputs. However, not only the 3.3-V and 5-V rails for the logic circuits on the motherboard need to be protected, but also the 12-V peripheral devices such as the hard disk, floppy disk, and CD-ROM players etc., need to be protected.

short-circuit power supply turnon

During safety testing the power supply might have tied the output voltage direct to ground. If this happens during the normal operating, this is called a short-circuit or over-current condition. When it happens before the power supply turns on, this is called a short-circuit power supply turnon. It can happen during the design period, in the production line, at quality control inspection or at the end user. The TPS3510/1 provides an undervoltage protection function with a 75-ms delay after $\overline{\text{PSON}}$ is set low.



POST OFFICE BOX 655303 • DALLAS, TEXAS 75265

absolute maximum ratings over operating free-air temperature (unless otherwise noted)†

Supply voltage, V_{DD} (see Note 1)	16 V
Output voltage V_O : \overline{FPO}	16 V
PGO	8 V
All other pins (see Note 1)	–0.3 V to 16 V
Continuous total power dissipation	See Dissipation Rating Table
Operating free-air temperature range, T_A	–40°C to 85°C
Storage temperature range, T_{stg}	–65°C to 150°C
Soldering temperature	260°C

† Stresses beyond those listed under “absolute maximum ratings” may cause permanent damage to the device. These are stress ratings only, and functional operation of the device at these or any other conditions beyond those indicated under “recommended operating conditions” is not implied. Exposure to absolute-maximum-rated conditions for extended periods may affect device reliability.

NOTE 1: All voltage values are with respect to GND.

DISSIPATION RATING TABLE

PACKAGE	$T_A \leq 25^\circ\text{C}$	DERATING FACTOR	$T_A = 70^\circ\text{C}$	$T_A = 85^\circ\text{C}$
	POWER RATING	ABOVE $T_A = 25^\circ\text{C}$	POWER RATING	POWER RATING
P	1092 mW	8.74 mW/°C	699 mW	568 mW
D	730 mW	5.84 mW/°C	467 mW	379 mW

recommended operating conditions at specified temperature range

		MIN	NOM	MAX	UNIT
Supply voltage, V_{DD}		4		15	V
Input voltage, V_I	\overline{PSON} , VS5, VS33			7	V
	PGI			$V_{DD} + 0.3\text{ V}$ (max = 7 V)	
Output voltage, V_O	\overline{FPO}			15	V
	PGO			7	
Output sink current, $I_{O,sink}$	\overline{FPO}			20	mA
	PGO			10	
Supply voltage rising time, t_r	See Note 2	1			ms
Operating free-air temperature range, T_A		–40		85	°C

NOTE 2: V_{DD} rising and falling slew rate must be less than 14 V/ms.

TPS3510,TPS3511 PC POWER SUPPLY SUPERVISORS

SLVS312A – JULY 2000 – REVISED DECEMBER 2002

electrical characteristics over recommended operating conditions (unless otherwise noted)

overvoltage protection

PARAMETER		TEST CONDITIONS	MIN	TYP	MAX	UNIT
Overvoltage threshold	VS33		3.7	3.9	4.1	V
	VS5		5.7	6.1	6.5	
	V _{DD}		13.2	13.8	14.4	
I _{LKG}	Leakage current (\overline{FPO})	V(\overline{FPO}) = 5 V			5	μA
V _{OL}	Low-level output voltage (\overline{FPO})	V _{DD} = 5 V, I _{sink} = 20 mA			0.7	V
	Noise deglitch time OVP	V _{DD} = 5 V	35	73	110	μs

PGI and PGO

PARAMETER		TEST CONDITIONS	MIN	TYP	MAX	UNIT		
V _{PGI}	Input threshold voltage (PGI)	PGI1	1.1	1.15	1.2	V		
		PGI2	0.9	0.95	1			
V _{IT}	Undervoltage threshold	VS33	2	2.2	2.4	V		
		VS5	3.3	3.5	3.7			
I _{LKG}	Leakage current (PGO)	PGO = 5 V			5	μA		
V _{OL}	Low-level output voltage (PGO)	V _{DD} = 4 V, I _{sink} = 10 mA			0.4	V		
	Short-circuit protection delay	3.3 V, 5 V	49	75	114	ms		
t _{d1}	Delay time	PGI to PGO	V _{DD} = 5 V	TP3510	200	300	450	ms
				TP3511	100	150	225	
				PGI to \overline{FPO}	3.2	4.8	7.2	
Noise deglitch time		PGI to PGO	V _{DD} = 5 V	88	150	225	μs	
		PGI to \overline{FPO}		180	296	445		
		UVP to \overline{FPO}		82	146	220		

PS_{ON} control

PARAMETER		TEST CONDITIONS	MIN	TYP	MAX	UNIT
I _I	Input pullup current	PS _{ON} = 0 V		120		μA
V _{IH}	High-level input voltage		2.4			V
V _{IL}	Low-level input voltage				1.2	V
t _b	Debounce time (\overline{PSON})	V _{DD} = 5 V	24	38	57	ms
t _{d2}	Delay time (\overline{PSON} to \overline{FPO})	V _{DD} = 5 V	t _b +1.1	t _b +2.3	t _b +4	ms

total device

PARAMETER		TEST CONDITIONS	MIN	TYP	MAX	UNIT
I _{DD}	Supply current	PS _{ON} = 5 V			1	mA



TYPICAL CHARACTERISTICS

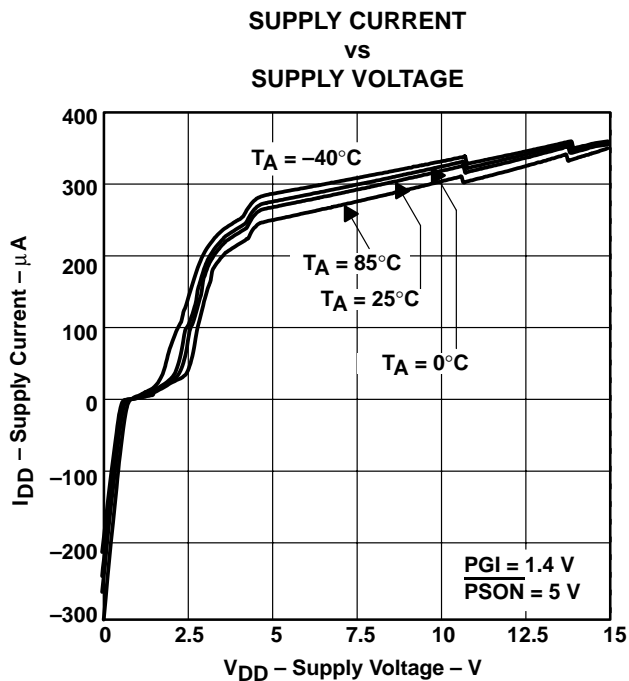

Figure 2

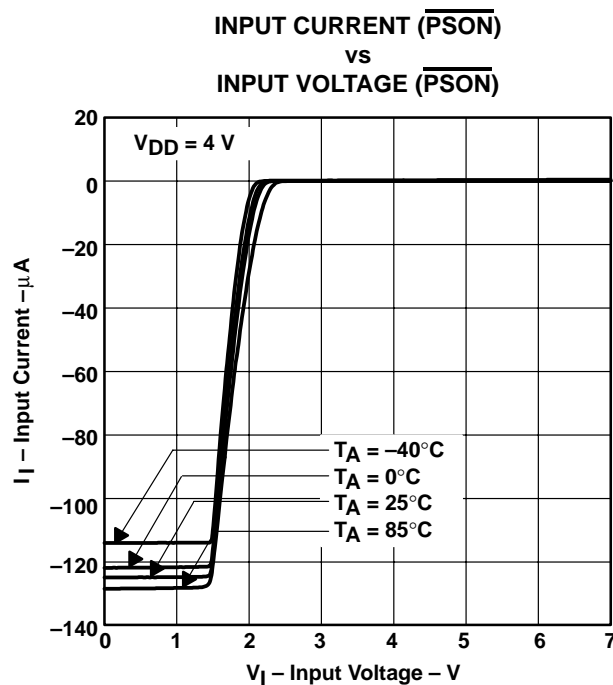

Figure 3

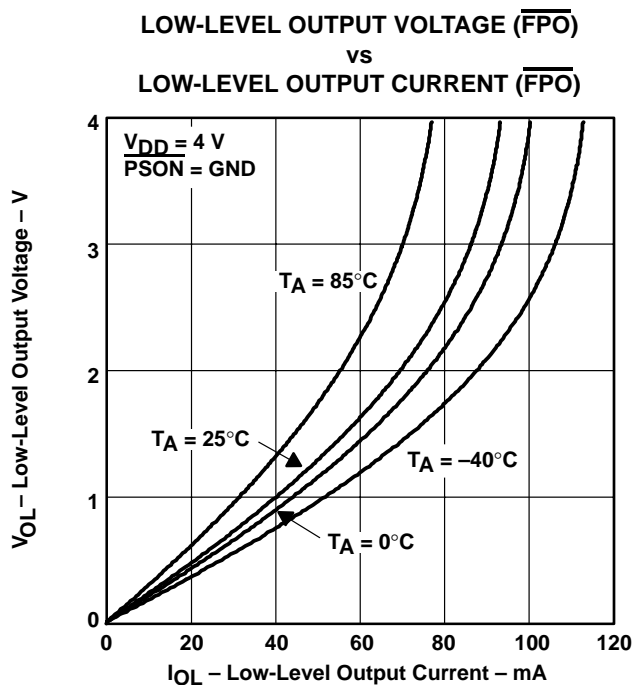

Figure 4

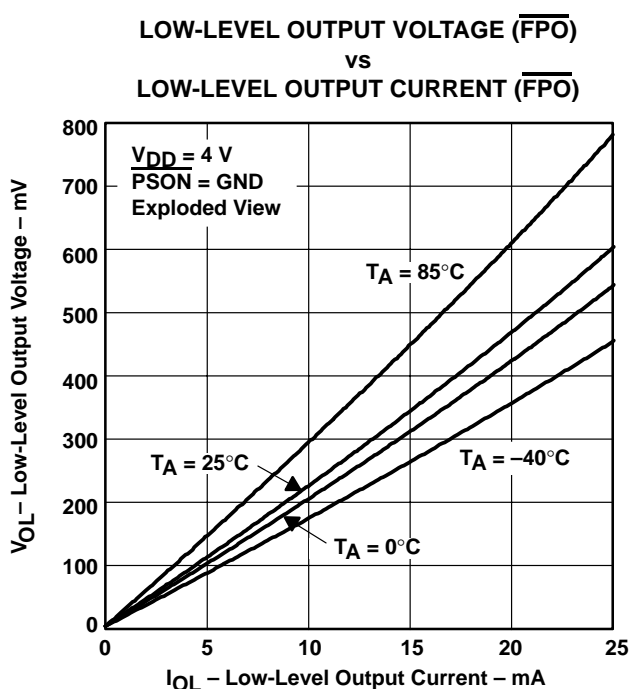

Figure 5

TYPICAL CHARACTERISTICS

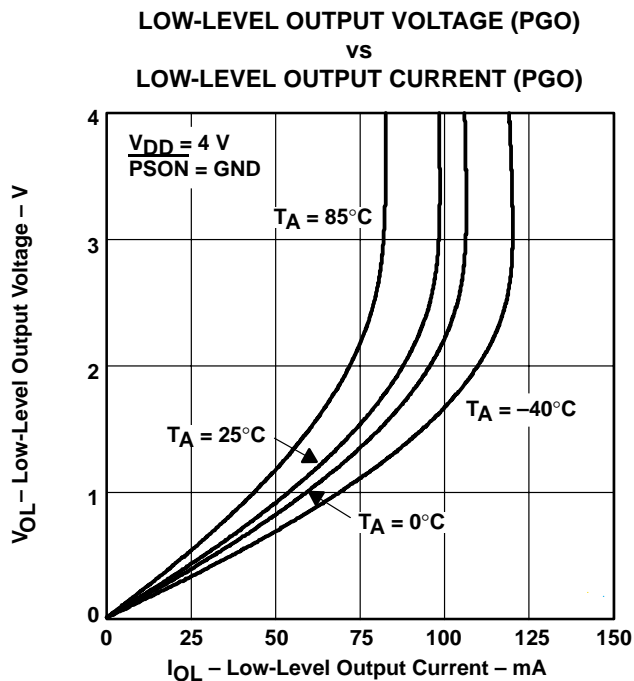

Figure 6

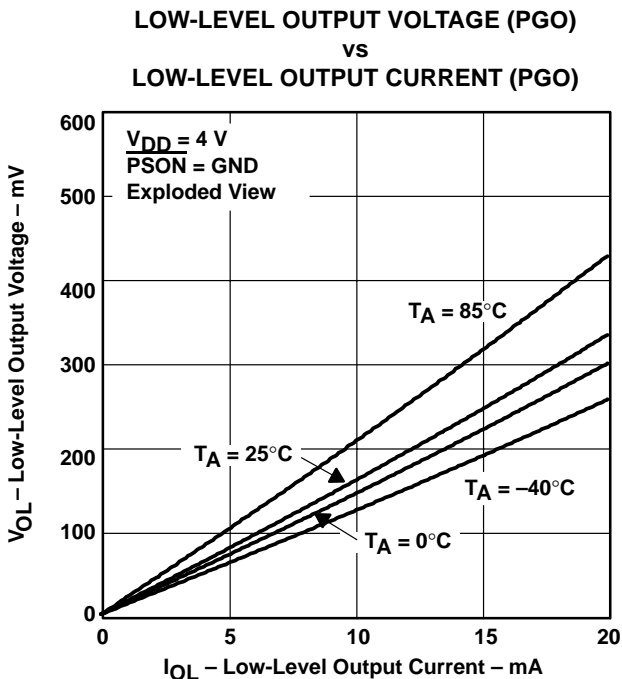

Figure 7

NORMALIZED SENSE THRESHOLD VOLTAGE
vs
FREE-AIR TEMPERATURE AT V_{DD}

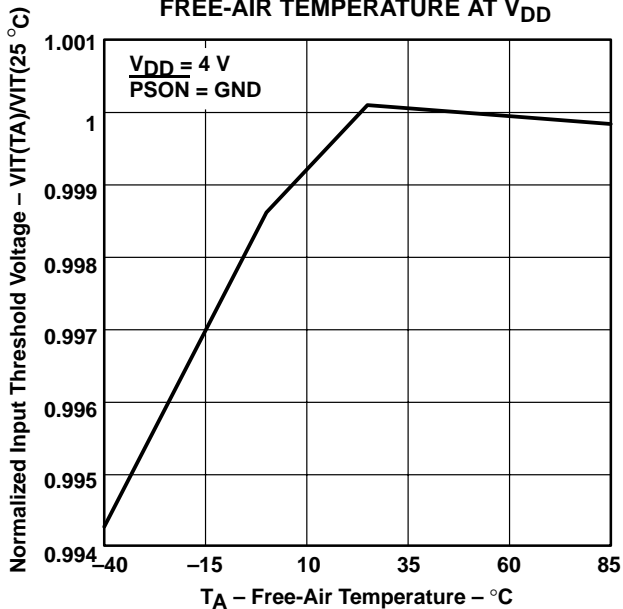

Figure 8

MECHANICAL DATA

D (R-PDSO-G**)

PLASTIC SMALL-OUTLINE PACKAGE

14 PINS SHOWN

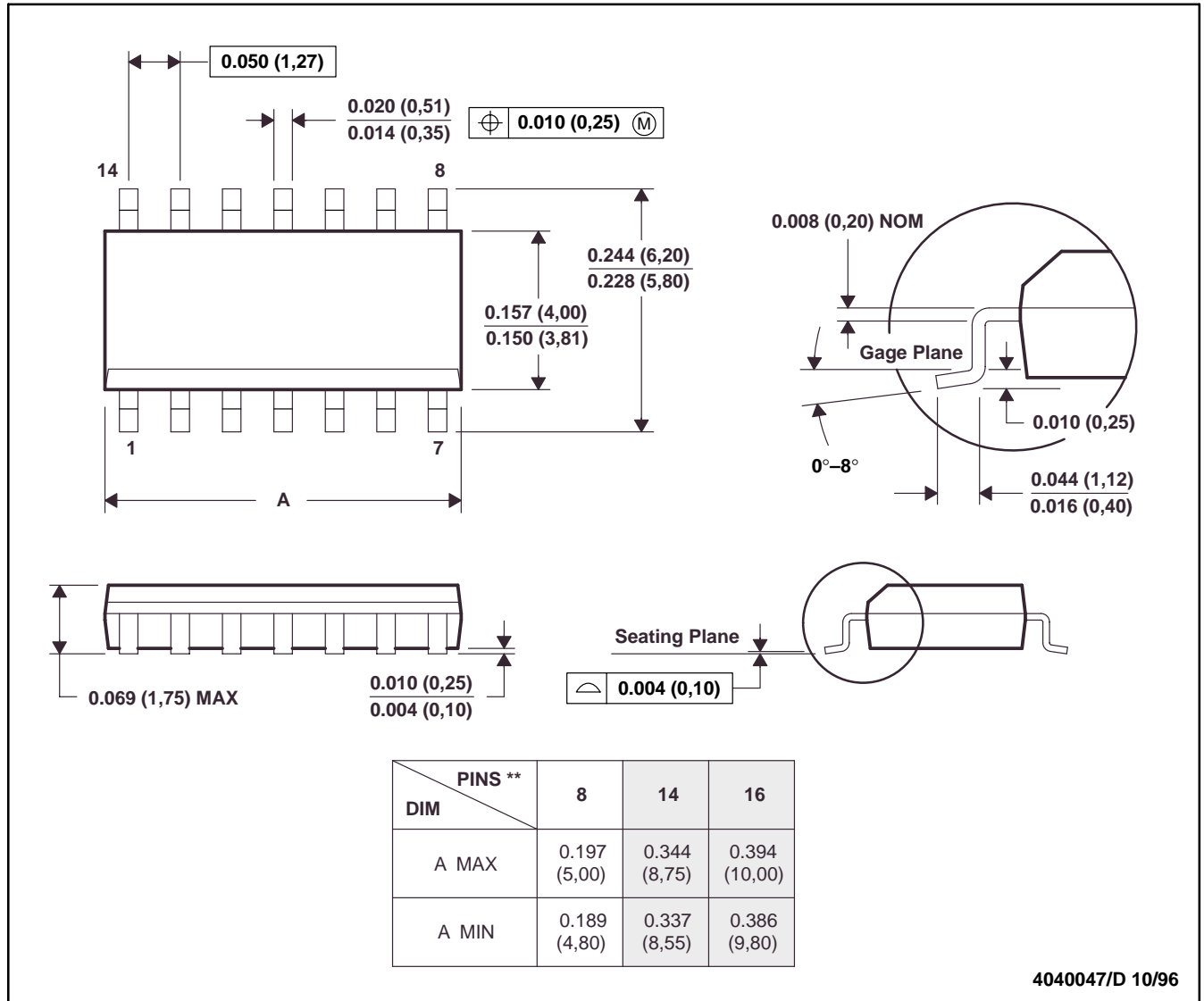

- NOTES: A. All linear dimensions are in inches (millimeters).
 B. This drawing is subject to change without notice.
 C. Body dimensions do not include mold flash or protrusion, not to exceed 0.006 (0,15).
 D. Falls within JEDEC MS-012

TPS3510, TPS3511 PC POWER SUPPLY SUPERVISORS

SLVS312A – JULY 2000 – REVISED DECEMBER 2002

MECHANICAL DATA

P (R-PDIP-T8)

PLASTIC DUAL-IN-LINE

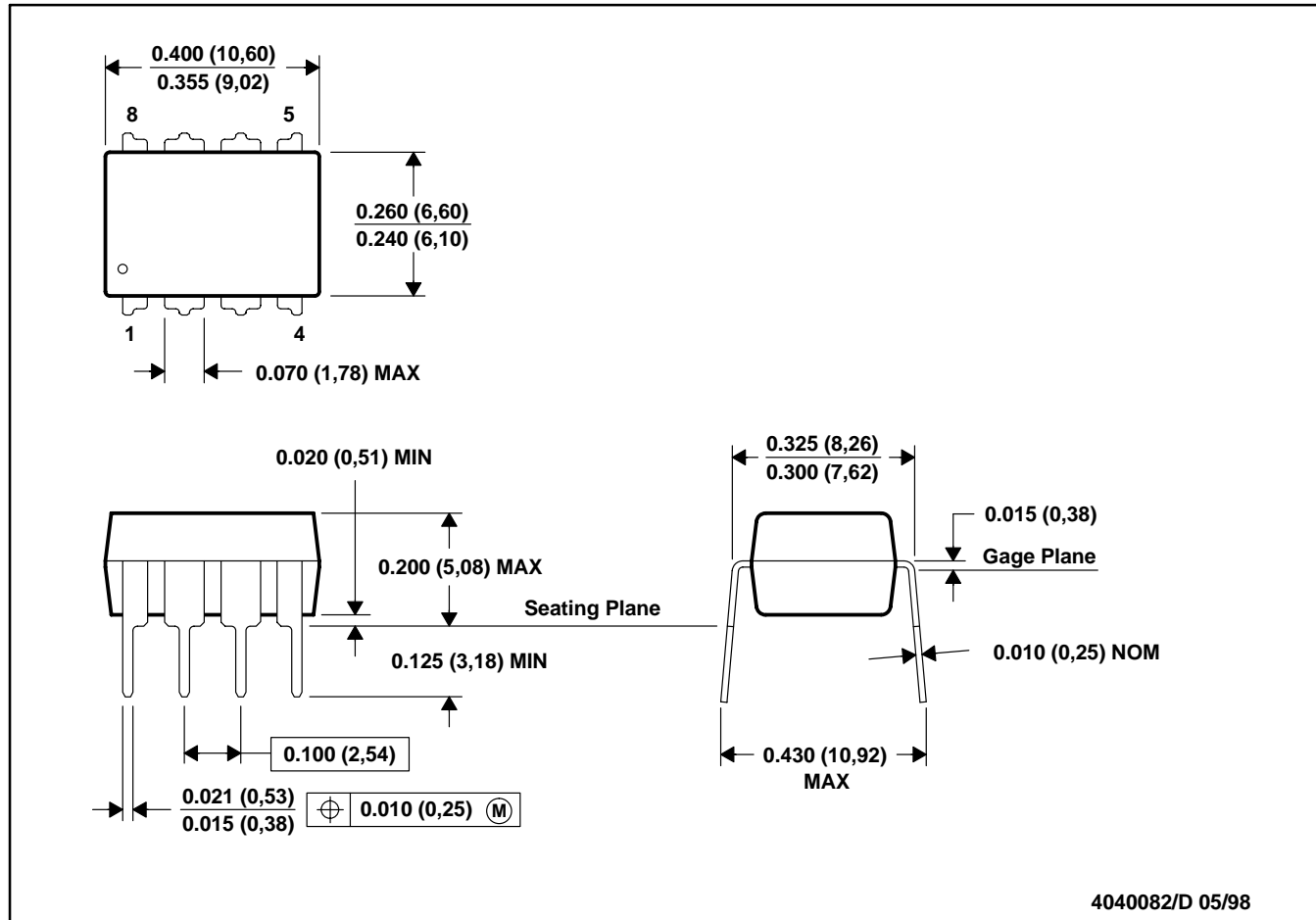

- NOTES: A. All linear dimensions are in inches (millimeters).
 B. This drawing is subject to change without notice.
 C. Falls within JEDEC MS-001

For the latest package information, go to http://www.ti.com/sc/docs/package/pkg_info.htm



POST OFFICE BOX 655303 • DALLAS, TEXAS 75265

IMPORTANT NOTICE

Texas Instruments Incorporated and its subsidiaries (TI) reserve the right to make corrections, modifications, enhancements, improvements, and other changes to its products and services at any time and to discontinue any product or service without notice. Customers should obtain the latest relevant information before placing orders and should verify that such information is current and complete. All products are sold subject to TI's terms and conditions of sale supplied at the time of order acknowledgment.

TI warrants performance of its hardware products to the specifications applicable at the time of sale in accordance with TI's standard warranty. Testing and other quality control techniques are used to the extent TI deems necessary to support this warranty. Except where mandated by government requirements, testing of all parameters of each product is not necessarily performed.

TI assumes no liability for applications assistance or customer product design. Customers are responsible for their products and applications using TI components. To minimize the risks associated with customer products and applications, customers should provide adequate design and operating safeguards.

TI does not warrant or represent that any license, either express or implied, is granted under any TI patent right, copyright, mask work right, or other TI intellectual property right relating to any combination, machine, or process in which TI products or services are used. Information published by TI regarding third-party products or services does not constitute a license from TI to use such products or services or a warranty or endorsement thereof. Use of such information may require a license from a third party under the patents or other intellectual property of the third party, or a license from TI under the patents or other intellectual property of TI.

Reproduction of information in TI data books or data sheets is permissible only if reproduction is without alteration and is accompanied by all associated warranties, conditions, limitations, and notices. Reproduction of this information with alteration is an unfair and deceptive business practice. TI is not responsible or liable for such altered documentation.

Resale of TI products or services with statements different from or beyond the parameters stated by TI for that product or service voids all express and any implied warranties for the associated TI product or service and is an unfair and deceptive business practice. TI is not responsible or liable for any such statements.

Mailing Address:

Texas Instruments
Post Office Box 655303
Dallas, Texas 75265