

DI-66 Design Idea TOPSwitch®-GX

45 W, Universal Input, LCD Monitor Internal Supply

Application	Device	Power Output	Input Voltage	Output Voltage	Topology
LCD Monitor	TOP246YN	45 W	90 – 265 VAC	5 V / 12 V	Flyback

Design Highlights

- 66 kHz operation enables 0.45 W of standby output power delivery with 0.9 W of input power at 230 VAC
- Low no-load input power: <0.42 W at 230 VAC
- 82% efficient (min) at 90 VAC input and 45 W output
- Low component count: only 52 parts!
- Meets CISPR22 B EMI with >10 dB of margin
- No TVS required for the primary snubber

Operation

Many of the built-in features of TOPSwitch-GX, such as line UV/OV, soft start, line feed-forward, accurate current limit, and frequency jitter have been used to reduce the component count, transformer size and overall system cost of this universal input, flyback power supply. This design is ideal for LCD monitor supplies that require low standby power consumption.

The switching frequency of U1 is set to 66 kHz by connecting its F pin to the CONTROL pin. Efficient 66 kHz operation results from

the use of an EER3016S core to keep the number of primary turns low and to further reduce T1 leakage inductance. This reduces the losses due to both leakage inductance and winding capacitance. Low leakage inductance also allows the use of a low cost RCD snubber (C3, R2–R4 and D5) to clamp the U1 DRAIN voltage, while keeping standby power consumption low. Use of a glass-passivated normal recovery diode (D5) recycles the stored leakage energy and increases the overall efficiency. Resistor R4 dampens drain node ringing, and is necessary when a normal recovery diode is used.

Resistor R5 sets nominal UV and OV limits to 84 V and 378 V, respectively. Under-voltage lockout protects the supply from overheating during brownout, and eliminates power-up and power-down glitches. Overvoltage shutdown protects the power supply from line surges.

Effective EMI filtering is accomplished with only five parts (L1, CX1, CY1-CY3), due to the built-in frequency jitter function of TOPSwitch-GX.

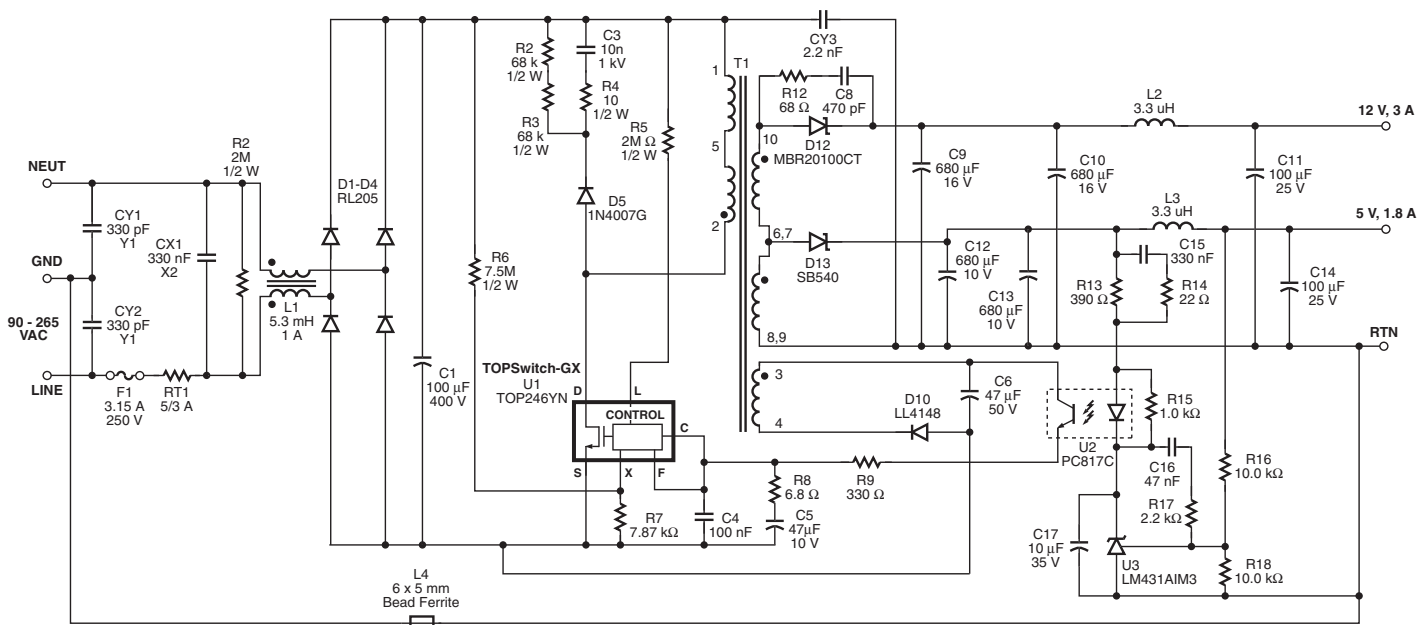

Figure 1. Circuit Diagram of a TOP246 Based LCD Monitor Power Supply.

Key Design Points

- Use 66 kHz operation to reduce standby power loss.
- To reduce the number of primary turns required for 66 kHz operation, the A_e of the T1 core must be large. Recommended cores are EER3016S and PQ2620.
- Split-primary transformer construction should be used to keep leakage inductance to a minimum.
- Use an RCD snubber with the normal recovery diode. Size resistors R2 and R3 for the highest value that ensures adequate drain voltage margin under overload conditions at high line.

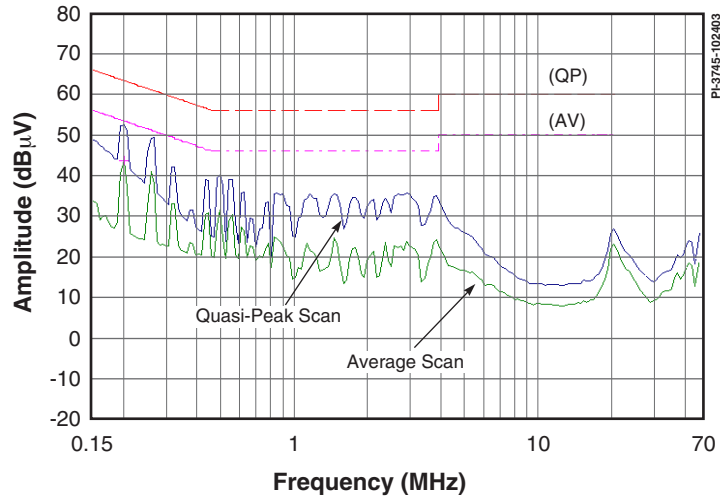

Figure 2. Conducted EMI, CISPR22B Limits, Maximum Load, Secondary Return Connected to Safety Ground, 230 VAC Input.

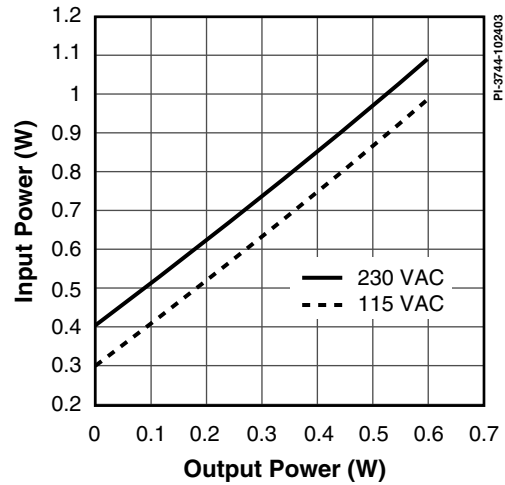

Figure 3. P_{in} vs. P_{out} 5 V Output Loaded, No Load on 12 V Output.

Transformer Parameters

Core Material	Samwha EER3016S-PL-7, gapped for ALG of 342 nH/t ²
Bobbin	10 pin, EER3016S
Winding Details	1/2 Primary: 28T, 26 AWG Bias: 7T, 2 × 26 AWG 12 V Secondary: 4T, 2 × 25 AWG T.I.W. 5 V Secondary: 3T, 3 × 25 AWG T.I.W.
Winding Order	1/2 Primary (2–5), tape 1L, Bias (3–4), tape 2L, 12 V Secondary (10–6,7), 5 V Secondary (6,7–8,9), tape 2L, 1/2 Primary (5–1), tape 3L
Primary Inductance	919 µH, ±10%
Primary Resonant Frequency	1.1 MHz (minimum)
Leakage Inductance	18 µH (maximum)

Table 1. Transformer Parameters. (AWG = American Wire Gauge, T.I.W. = Triple Insulated Wire)

Power Integrations
5245 Hellyer Avenue
San Jose, CA 95138, USA.
Main: +1 408-414-9200
Customer Service
Phone: +1-408-414-9665
Fax: +1-408-414-9765
Email: usasales@powerint.com

On the Web
www.powerint.com

Power Integrations reserves the right to make changes to its products at any time to improve reliability or manufacturability. Power Integrations does not assume any liability arising from the use of any device or circuit described herein. POWER INTEGRATIONS MAKES NO WARRANTY HEREIN AND SPECIFICALLY DISCLAIMS ALL WARRANTIES INCLUDING, WITHOUT LIMITATION, THE IMPLIED WARRANTIES OF MERCHANTABILITY, FITNESS FOR A PARTICULAR PURPOSE, AND NON-INFRINGEMENT OF THIRD PARTY RIGHTS. The products and applications illustrated herein (transformer construction and circuits external to the products) may be covered by one or more U.S. and foreign patents or potentially by pending U.S. and foreign patent applications assigned to Power Integrations. A complete list of Power Integrations' patents may be found at www.powerint.com. Power Integrations grants its customers a license under certain patent rights as set forth at <http://www.powerint.com/ip.htm>.

The PI logo, TOPSwitch, TinySwitch, LinkSwitch, DPA-Switch, PeakSwitch, EcoSmart, Clampless, E-Shield, Filterfuse, StackFET, PI Expert and PI FACTS are trademarks of Power Integrations, Inc. Other trademarks are property of their respective companies. ©2004, Power Integrations, Inc.