

TYPES SN5490A, SN5492A, SN5493A, SN54L90, SN54L93, SN54LS90, SN54LS92, SN54LS93, SN7490A, SN7492A, SN7493A, SN74LS90, SN74LS92, SN74LS93 DECADE, DIVIDE-BY-TWELVE, AND BINARY COUNTERS

MARCH 1974 — REVISED DECEMBER 1983

'90A, 'L90, 'LS90 . . . DECADE COUNTERS

'92A, 'LS92 . . . DIVIDE-BY-TWELVE COUNTERS

'93A, 'L93, 'LS93 . . . 4-BIT BINARY COUNTERS

TYPES	TYPICAL POWER DISSIPATION
'90A	145 mW
'L90	20 mW
'LS90	45 mW
'92A, '93A	130 mW
'LS92, 'LS93	45 mW
'L93	16 mW

description

Each of these monolithic counters contains four master-slave flip-flops and additional gating to provide a divide-by-two counter and a three-stage binary counter for which the count cycle length is divide-by-five for the '90A, 'L90, and 'LS90, divide-by-six for the '92A and 'LS92, and divide-by-eight for the '93A, 'L93, and 'LS93.

All of these counters have a gated zero reset and the '90A, 'L90, and 'LS90 also have gated set-to-nine inputs for use in BCD nine's complement applications.

To use their maximum count length (decade, divide-by-twelve, or four-bit binary) of these counters, the CKB input is connected to the Q_A output. The input count pulses are applied to CKA input and the outputs are as described in the appropriate function table. A symmetrical divide-by-ten count can be obtained from the '90A, 'L90, or 'LS90 counters by connecting the Q_D output to the CKA input and applying the input count to the CKB input which gives a divide-by-ten square wave at output Q_A .

SN5490A, SN54LS90 . . . J OR W PACKAGE SN54L90 . . . J PACKAGE SN7490A . . . J OR N PACKAGE SN74LS90 . . . D, J OR N PACKAGE (TOP VIEW)

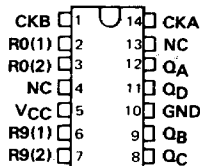

SN5492A, SN54LS92 . . . J OR W PACKAGE SN7492A . . . J OR N PACKAGE SN74LS92 . . . D, J OR N PACKAGE (TOP VIEW)

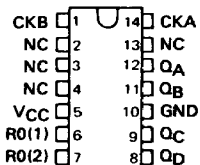

SN5493A, SN54LS93 . . . J OR W PACKAGE SN7493A . . . J OR N PACKAGE SN74LS93 . . . D, J OR N PACKAGE (TOP VIEW)

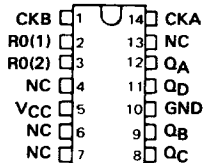

SN54L93 . . . J PACKAGE (TOP VIEW)

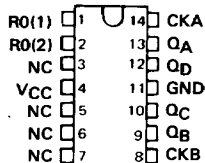

NC - No internal connection

For new chip carrier design, use
'LS290, 'LS292, and 'LS293.

PRODUCTION DATA
This document contains information current as of publication date. Products conform to specifications per the terms of Texas Instruments standard warranty. Production processing does not necessarily include testing of all parameters.

TEXAS INSTRUMENTS
POST OFFICE BOX 225012 • DALLAS, TEXAS 75265

3-357

3

TTL DEVICES

**TYPES SN5490A, '92A, '93A, SN54L90, 'L93, SN54LS90, 'LS92, 'LS93,
SN7490A, '92A, '93A, SN74LS90, 'LS92, 'LS93
DECADE, DIVIDE-BY-TWELVE, AND BINARY COUNTERS**

**'90A, 'L90, 'LS90
BCD COUNT SEQUENCE
(See Note A)**

COUNT	OUTPUT			
	Q _D	Q _C	Q _B	Q _A
0	L	L	L	L
1	L	L	L	H
2	L	L	H	L
3	L	L	H	H
4	L	H	L	L
5	L	H	L	H
6	L	H	H	L
7	L	H	H	H
8	H	L	L	L
9	H	L	L	H

**'90A, 'L90, 'LS90
BI-QUINARY (5-2)
(See Note B)**

COUNT	OUTPUT			
	Q _A	Q _D	Q _C	Q _B
0	L	L	L	L
1	L	L	L	H
2	L	L	H	L
3	L	L	H	H
4	L	H	L	L
5	H	L	L	L
6	H	L	L	H
7	H	L	H	L
8	H	L	H	H
9	H	H	L	L

**'92A, 'LS92
COUNT SEQUENCE
(See Note C)**

COUNT	OUTPUT			
	Q _D	Q _C	Q _B	Q _A
0	L	L	L	L
1	L	L	L	H
2	L	L	H	L
3	L	L	H	H
4	L	H	L	L
5	L	H	L	H
6	H	L	L	L
7	H	L	L	H
8	H	L	H	L
9	H	L	H	H
10	H	H	L	L
11	H	H	L	H

**'90A, 'L90, 'LS90
RESET/COUNT FUNCTION TABLE**

RESET INPUTS				OUTPUT			
R ₀ (1)	R ₀ (2)	R ₉ (1)	R ₉ (2)	Q _D	Q _C	Q _B	Q _A
H	H	L	X	L	L	L	L
H	H	X	L	L	L	L	L
X	X	H	H	H	L	L	H
X	L	X	L	COUNT			
L	X	L	X	COUNT			
L	X	X	L	COUNT			
X	L	L	X	COUNT			

**'93A, 'L93, 'LS93
COUNT SEQUENCE
(See Note C)**

COUNT	OUTPUT			
	Q _D	Q _C	Q _B	Q _A
0	L	L	L	L
1	L	L	L	H
2	L	L	H	L
3	L	L	H	H
4	L	H	L	L
5	L	H	L	H
6	L	H	H	L
7	L	H	H	H
8	H	L	L	L
9	H	L	L	H
10	H	L	H	L
11	H	L	H	H
12	H	H	L	L
13	H	H	L	H
14	H	H	H	L
15	H	H	H	H

**'92A, 'LS92, '93A, 'L93, 'LS93
RESET/COUNT FUNCTION TABLE**

RESET INPUTS		OUTPUT			
R ₀ (1)	R ₀ (2)	Q _D	Q _C	Q _B	Q _A
H	H	L	L	L	L
L	X	COUNT			
X	L	COUNT			

- NOTES: A. Output Q_A is connected to input CKB for BCD count.
B. Output Q_D is connected to input CKA for bi-quinary count.
C. Output Q_A is connected to input CKB.
D. H = high level, L = low level, X = irrelevant

3

TTL DEVICES

**TYPES SN5490A, '92A, '93A, SN54L90, 'L93, SN54LS90, 'LS92, 'LS93
SN7490A, '92A, '93A, SN74LS90, 'LS92, 'LS93
DECADE, DIVIDE-BY-TWELVE, AND BINARY COUNTERS**

logic diagrams

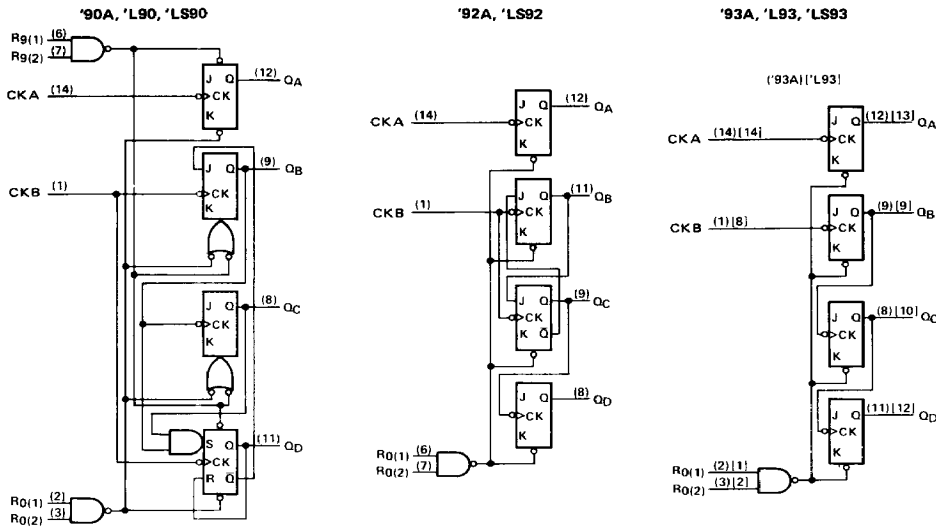

The J and K inputs shown without connection are for reference only and are functionally at a high level. Pin numbers shown in () are for the 'LS93 and '93A and pin numbers shown in [] are for the 54L93.

schematics of inputs and outputs

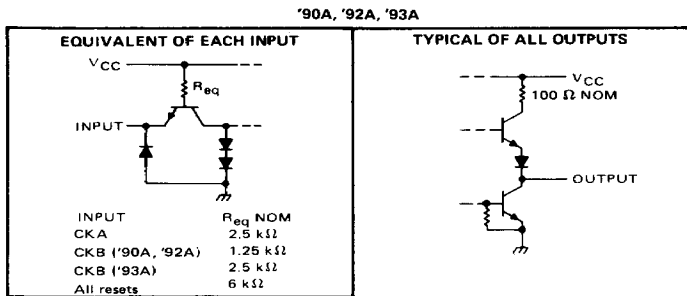

3
TTL DEVICES

**TYPES SN54L90, 'L93, SN54LS90, 'LS92, 'LS93
SN74LS90, 'LS92, 'LS93
DECADE, DIVIDE-BY-TWELVE, AND BINARY COUNTERS**

schematics of inputs and outputs (continued)

'L90, 'L93

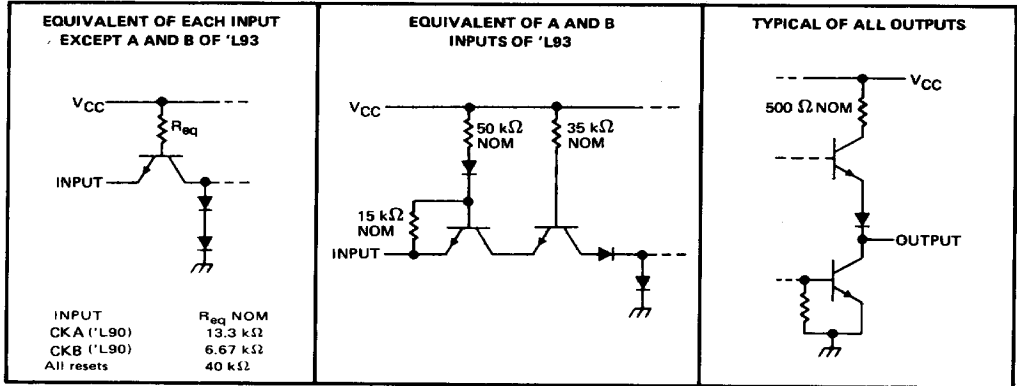

'LS90, 'LS92, 'LS93

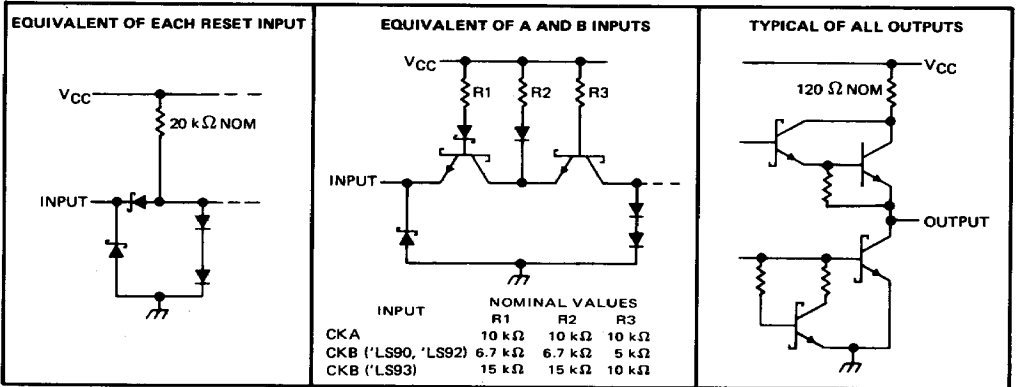

3

TTL DEVICES

TYPES SN5490A, SN5492A, SN5493A, SN7490A, SN7492A, SN7493A DECADE, DIVIDE-BY-TWELVE, AND BINARY COUNTERS

absolute maximum ratings over operating free-air temperature range (unless otherwise noted)

Supply voltage, V_{CC} (see Note 1)	7 V
Input voltage	5.5 V
Intermitter voltage (see Note 2)	5.5 V
Operating free-air temperature range: SN5490A, SN5492A, SN5493A	-55°C to 125°C
SN7490A, SN7492A, SN7493A	0°C to 70°C
Storage temperature range	-65°C to 150°C

NOTES: 1. Voltage values, except intermitter voltage, are with respect to network ground terminal.
2. This is the voltage between two emitters of a multiple-emitter transistor. For these circuits, this rating applies between the two R_O inputs, and for the '90A circuit, it also applies between the two R_O inputs.

recommended operating conditions

	SN5490A, SN5492A SN5493A			SN7490A, SN7492A SN7493A			UNIT
	MIN	NOM	MAX	MIN	NOM	MAX	
Supply voltage, V_{CC}	4.5	5	5.5	4.75	5	5.25	V
High-level output current, I_{OH}	-800			-800			μ A
Low-level output current, I_{OL}	16			16			mA
Count frequency, f_{COUNT} (see Figure 1)	A input	0	32	0	32		MHz
	B input	0	16	0	16		
Pulse width, t_w	A input	15		15			ns
	B input	30		30			
	Reset inputs	15		15			
Reset inactive-state setup time, t_{SU}	25			25			ns
Operating free-air temperature, T_A	-55		125	0		70	°C

electrical characteristics over recommended operating free-air temperature range (unless otherwise noted)

PARAMETER [¶]	TEST CONDITIONS [†]	'90A		'92A		'93A		UNIT	
		MIN	TYP [‡]	MAX	MIN	TYP [‡]	MAX		MIN
V_{IH} High-level input voltage		2		2		2		V	
V_{IL} Low-level input voltage		0.8		0.8		0.8		V	
V_{IK} Input clamp voltage	$V_{CC} = \text{MIN}, I_I = -12 \text{ mA}$	-1.5		-1.5		-1.5		V	
V_{OH} High-level output voltage	$V_{CC} = \text{MIN}, V_{IH} = 2 \text{ V}, V_{IL} = 0.8 \text{ V}, I_{OH} = -800 \mu\text{A}$	2.4	3.4	2.4	3.4	2.4	3.4	V	
V_{OL} Low-level output voltage	$V_{CC} = \text{MIN}, V_{IH} = 2 \text{ V}, V_{IL} = 0.8 \text{ V}, I_{OL} = 16 \text{ mA} ¶$	0.2 0.4		0.2 0.4		0.2 0.4		V	
I_I Input current at maximum input voltage	$V_{CC} = \text{MAX}, V_I = 5.5 \text{ V}$	1		1		1		mA	
I_{IH} High-level input current	Any reset	40		40		40		μ A	
	CKA	80		80		80			
	CKB	120		120		80			
I_{IL} Low-level input current	Any reset	-1.6		-1.6		-1.6		mA	
	CKA	-3.2		-3.2		-3.2			
	CKB	-4.8		-4.8		-3.2			
I_{OS} Short-circuit output current [§]	$V_{CC} = \text{MAX}$	SN54 [¶]	-20	-57	-20	-57	-20	-57	mA
		SN74 [¶]	-18	-57	-18	-57	-18	-57	
I_{CC} Supply current	$V_{CC} = \text{MAX}, \text{ See Note 3}$	29	42	26	39	26	39	mA	

[†] For conditions shown as MIN or MAX, use the appropriate value specified under recommended operating conditions.

[‡] All typical values are at $V_{CC} = 5 \text{ V}, T_A = 25^\circ \text{ C}$.

[§] Not more than one output should be shorted at a time.

[¶] Q_A outputs are tested at $I_{OL} = 16 \text{ mA}$ plus the limit value for I_{IL} for the CKB input. This permits driving the CKB input while maintaining full fan-out capability.

NOTE 3: I_{CC} is measured with all outputs open, both R_O inputs grounded following momentary connection to 4.5 V, and all other inputs grounded.

3

TTL DEVICES

**TEXAS
INSTRUMENTS**

POST OFFICE BOX 225012 • DALLAS, TEXAS 75265

3-361

**TYPES SN5490A, SN5492A, SN5493A, SN7490A, SN7492A, SN7493A
DECADE, DIVIDE-BY-TWELVE, AND BINARY COUNTERS**

switching characteristics, $V_{CC} = 5\text{ V}$, $T_A = 25^\circ\text{C}$

PARAMETER ¹	FROM (INPUT)	TO (OUTPUT)	TEST CONDITIONS	'90A			'92A			'93A			UNIT
				MIN	TYP	MAX	MIN	TYP	MAX	MIN	TYP	MAX	
f_{\max}	CKA	Q_A	$C_L = 15\text{ pF}$, $R_L = 400\ \Omega$, See Figure 1	32	42		32	42		32	42		MHz
	CKB	Q_B		16			16			16			
t_{PLH}	CKA	Q_A		10	16		10	16		10	16		ns
t_{PHL}		Q_D		12	18		12	18		12	18		
t_{PLH}	CKA	Q_D		32	48		32	48		46	70		ns
t_{PHL}		Q_B		34	50		34	50		46	70		
t_{PLH}	CKB	Q_B		10	16		10	16		10	16		ns
t_{PHL}		Q_C		14	21		14	21		14	21		
t_{PLH}	CKB	Q_C		21	32		10	16		21	32		ns
t_{PHL}		Q_D		23	35		14	21		23	35		
t_{PLH}	CKB	Q_D		21	32		21	32		34	51		ns
t_{PHL}		Any		23	35		23	35		34	51		
t_{PHL}	Set-to-0	Any		26	40		26	40		26	40		ns
t_{PLH}	Set-to-9	Q_A, Q_D		20	30								ns
t_{PHL}		Q_B, Q_C		26	40								

¹ f_{\max} maximum count frequency
 t_{PLH} propagation delay time, low to high-level output
 t_{PHL} propagation delay time, high to low-level output

3

TTL DEVICES

3-362

TEXAS
INSTRUMENTS

POST OFFICE BOX 225012 • DALLAS, TEXAS 75265

TYPES SN54L90, SN54L93 DECADE AND BINARY COUNTERS

absolute maximum ratings over operating free-air temperature range (unless otherwise noted)

Supply voltage, V_{CC} (see Note 1)	8 V
Input voltage (see Note 2)	5.5 V
Operating free-air temperature range:	-55°C to 125°C
Storage temperature range	-65°C to 150°C

- NOTES: 1. Voltage values are with respect to network ground terminal.
2. Input voltages must be zero or positive with respect to network ground terminal.

recommended operating conditions

		SN54L90, SN54L93			UNIT
		MIN	NOM	MAX	
V_{CC}	Supply voltage	4.5	5	5.5	V
f_{count}	Count frequency	0		3	MHz
I_{OH}	High-level output current			-0.1	mA
I_{OL}	Low-level output current			2	mA
$t_w(\text{count})$	Width of input count pulse	200			ns
$t_w(\text{reset})$	Width of reset pulse	200			ns
T_A	Operating free-air temperature	-55	125		°C

electrical characteristics over recommended operating free-air temperature range (unless otherwise noted)

PARAMETER		TEST CONDITIONS†	SN54L90		SN54L93		UNIT	
			MIN	TYP‡	MAX	MIN		TYP‡
V_{IH}	High-level input voltage		2		2		V	
V_{IL}	Low-level input voltage			0.7		0.7	V	
V_{OH}	High-level output voltage	$V_{CC} = \text{MIN}, V_{IH} = 2 \text{ V}, V_{IL} = 0.7 \text{ V}, I_{OH} = \text{MAX}$	2.4	3.3	2.4	3.3	V	
V_{OL}	Low-level output voltage	$V_{CC} = \text{MIN}, V_{IH} = 2 \text{ V}, V_{IL} = 0.7 \text{ V}, I_{OL} = \text{MAX}^{\ddagger}$	0.15	0.3	0.15	0.3	V	
I_I	Input current at maximum input voltage	Any reset input		100		100	μA	
		CKA	$V_{CC} = \text{MAX}, V_I = 5.5 \text{ V}$	300	200			
		CKB		600	200			
I_{IH}	High-level input current	Any reset input		10		10	μA	
		CKA	$V_{CC} = \text{MAX}, V_I = 2.4 \text{ V}$	30	20			
		CKB		60	20			
I_{IL}	Low-level input current	Any reset input		-0.18		-0.18	mA	
		CKA	$V_{CC} = \text{MAX}, V_I = 0.3 \text{ V}$	-0.54	-0.36			
		CKB		-1.08	-0.36			
I_{QS}	Short-circuit output current§	$V_{CC} = \text{MAX}$	-3	-15	-3	-15	mA	
I_{CC}	Supply current	$V_{CC} = \text{MAX}, \text{ See Note 3}$		4	7.2	3.2	6.6	mA

† For conditions shown as MIN or MAX, use the appropriate value specified under recommended operating conditions.

‡ All typical values are at $V_{CC} = 5 \text{ V}, T_A = 25^\circ\text{C}$.

§ Not more than one output should be shorted at a time.

¶ QA outputs are tested at $I_{OL} = \text{MAX}$ plus the limit value for I_{IL} for the CKB input. This permits driving the CKB input while maintaining full fan-out capability.

NOTE 3: I_{CC} is measured with all outputs open, both R_D inputs grounded following momentary connection to 4.5 V, and all other inputs grounded.

switching characteristics, $V_{CC} = 5 \text{ V}, T_A = 25^\circ\text{C}$

PARAMETER	TEST CONDITIONS	SN54L90			SN54L93			UNIT
		MIN	TYP	MAX	MIN	TYP	MAX	
f_{max}	Maximum count frequency	3	6		3	6		MHz
t_{PLH}	Propagation delay time, low-to-high-level Q_D output from input CKA		230	340		280	450	ns
t_{PHL}	Propagation delay time, high-to-low-level Q_D output from input CKB		230	340		280	450	ns

TEXAS
INSTRUMENTS

POST OFFICE BOX 225012 • DALLAS, TEXAS 75265

3-363

3

TTL DEVICES

TYPES SN54LS90, SN54LS92, SN54LS93, SN74LS90, SN74LS92, SN74LS93 DECADE, DIVIDE-BY-TWELVE, AND BINARY COUNTERS

absolute maximum ratings over operating free-air temperature range (unless otherwise noted)

Supply voltage, V_{CC} (see Note 1)	7 V
Input voltage: R inputs	7 V
A and B inputs	5.5 V
Operating free-air temperature range: SN54LS [†] Circuits	-55°C to 125°C
SN74LS [†] Circuits	0°C to 70°C
Storage temperature range	-65°C to 150°C

NOTE 1: Voltage values are with respect to network ground terminal.

recommended operating conditions

	SN54LS90 SN54LS92 SN54LS93			SN74LS90 SN74LS92 SN74LS93			UNIT
	MIN	NOM	MAX	MIN	NOM	MAX	
Supply voltage, V_{CC}	4.5	5	5.5	4.75	5	5.25	V
High-level output current, I_{OH}							-400 μ A
Low-level output current, I_{OL}							8 mA
Count frequency, f_{count} (see Figure 1)	A input	0	32	0	32		MHz
	B input	0	16	0	16		
Pulse width, t_w	A input	15		15			ns
	B input	30		30			
	Reset inputs	30		30			
Reset inactive-state setup time, t_{SU}	25			25			ns
Operating free-air temperature, T_A	-55			125	0	70	°C

electrical characteristics over recommended operating free-air temperature range (unless otherwise noted)

PARAMETER	TEST CONDITIONS [†]	SN54LS90 SN54LS92			SN74LS90 SN74LS92			UNIT		
		MIN	TYP [‡]	MAX	MIN	TYP [‡]	MAX			
V_{IH} High-level input voltage		2			2			V		
V_{IL} Low-level input voltage				0.7			0.8	V		
V_{IK} Input clamp voltage	$V_{CC} = \text{MIN}, I_I = -18 \text{ mA}$			-1.5			-1.5	V		
V_{OH} High-level output voltage	$V_{CC} = \text{MIN}, V_{IH} = 2 \text{ V}, V_{IL} = V_{IL \text{ max}}, I_{OH} = -400 \mu\text{A}$	2.5	3.4		2.7	3.4		V		
V_{OL} Low-level output voltage	$V_{CC} = \text{MIN}, V_{IH} = 2 \text{ V}, V_{IL} = V_{IL \text{ max}},$	$I_{OL} = 4 \text{ mA}^\S$		0.25	0.4	$I_{OL} = 4 \text{ mA}^\S$		0.25	0.4	
		$I_{OL} = 8 \text{ mA}^\P$				$I_{OL} = 8 \text{ mA}^\P$		0.35		0.5
I_I Input current at maximum input voltage	Any reset	$V_{CC} = \text{MAX}, V_I = 7 \text{ V}$				$V_{CC} = \text{MAX}, V_I = 7 \text{ V}$				
	CKA			0.1				0.1		
	CKB	$V_{CC} = \text{MAX}, V_I = 5.5 \text{ V}$		0.2				0.2		
I_{IH} High-level input current	Any reset	$V_{CC} = \text{MAX}, V_I = 2.7 \text{ V}$		20				20		
	CKA			40				40		
	CKB			80				80		
I_{IL} Low-level input current	Any reset	$V_{CC} = \text{MAX}, V_I = 0.4 \text{ V}$		-0.4				-0.4		
	CKA			-2.4				-2.4		
	CKB			-3.2				-3.2		
I_{OS} Short-circuit output current [§]	$V_{CC} = \text{MAX}$			-20	-100			-20	-100	
I_{CC} Supply current	$V_{CC} = \text{MAX},$ See Note 3									
				LS90		LS92				
				9		15		9		15
				9		15		9		15

[†]For conditions shown as MIN or MAX, use the appropriate value specified under recommended operating conditions.

[‡]All typical values are at $V_{CC} = 5 \text{ V}, T_A = 25^\circ\text{C}$.

[§]Not more than one output should be shorted at a time, and duration of the short-circuit should not exceed one second.

[¶] I_{QA} outputs are tested at specified I_{OL} plus the limit value of I_{IL} for the CKB input. This permits driving the CKB input while maintaining full fan-out capability.

NOTE 3: I_{CC} is measured with all outputs open, both R_O inputs grounded following momentary connection to 4.5 V, and all other inputs grounded.

3 TTL DEVICES

TYPES SN54LS90, SN54LS92, SN54LS93, SN74LS90, SN74LS92, SN74LS93 DECADE, DIVIDE-BY-TWELVE, AND BINARY COUNTERS

electrical characteristics over recommended operating free-air temperature range (unless otherwise noted)

PARAMETER		TEST CONDITIONS [†]	SN54LS93			SN74LS93			UNIT
			MIN	TYP [‡]	MAX	MIN	TYP [‡]	MAX	
V _{IH}	High-level input voltage		2			2		V	
V _{IL}	Low-level input voltage				0.7		0.8	V	
V _{IK}	Input clamp voltage	V _{CC} = MIN, I _I = -18 mA			-1.5		-1.5	V	
V _{OH}	High-level output voltage	V _{CC} = MIN, V _{IH} = 2 V, V _{IL} = V _{IL} max, I _{OH} = -400 μA	2.5	3.4		2.7	3.4	V	
V _{OL}	Low-level output voltage	V _{CC} = MIN, V _{IH} = 2 V, V _{IL} = V _{IL} max			0.25 0.4		0.25 0.4	V	
I _I	Input current at maximum input voltage	Any reset			0.1		0.1	mA	
		CKA or CKB			0.2		0.2		
I _{IH}	High-level input current	Any reset			20		20	μA	
		CKA or CKB			40		80		
I _{IL}	Low-level input current	Any reset			-0.4		-0.4	mA	
		CKA			-2.4		-2.4		
		CKB			-1.6		-1.6		
I _{OS}	Short-circuit output current [§]	V _{CC} = MAX	-20	-100	-20	-100	mA		
I _{CC}	Supply current	V _{CC} = MAX, See Note 3		9 15		9 15	mA		

[†] For conditions shown as MIN or MAX, use the appropriate value specified under recommended operating conditions.

[‡] All typical values are at V_{CC} = 5 V, T_A = 25°C.

[§] Not more than one output should be shorted at a time, and duration of the short-circuit should not exceed one second.

[¶] Q_A outputs are tested at specified I_{OL} plus the limit value for I_{IL} for the CKB input. This permits driving the CKB input while maintaining full fan-out capability.

NOTE 3: I_{CC} is measured with all outputs open, both R₀ inputs grounded following momentary connection to 4.5 V, and all other inputs grounded.

switching characteristics, V_{CC} = 5 V, T_A = 25°C

PARAMETER [¶]	FROM (INPUT)	TO (OUTPUT)	TEST CONDITIONS	'LS90			'LS92			'LS93			UNIT
				MIN	TYP	MAX	MIN	TYP	MAX	MIN	TYP	MAX	
f _{max}	CKA	Q _A	C _L = 15 pF, R _L = 2 kΩ See Figure 1	32	42		32	42		32	42		MHz
	CKB	Q _B		16			16			16			
[†] PLH	CKA	Q _A		10	16		10	16		10	16		ns
[†] PHL				12	18		12	18		12	18		
[†] PLH	CKA	Q _D		32	48		32	48		46	70		ns
[†] PHL				34	50		34	50		46	70		
[†] PLH	CKB	Q _B		10	16		10	16		10	16		ns
[†] PHL				14	21		14	21		14	21		
[†] PLH	CKB	Q _C		21	32		10	16		21	32		ns
[†] PHL				23	35		14	21		23	35		
[†] PLH	CKB	Q _D		21	32		21	32		34	51		ns
[†] PHL				23	35		23	35		34	51		
[†] PHL	Set-to-0	Any		26	40		26	40		26	40		ns
[†] PLH	Set-to-9	Q _A , Q _D		20	30								ns
[†] PHL		Q _B , Q _C	26	40									

[¶] f_{max} ≡ maximum count frequency

[†]PLH ≡ propagation delay time, low to high level output

[†]PHL ≡ propagation delay time, high to low level output

3

TTL DEVICES

**TEXAS
INSTRUMENTS**

POST OFFICE BOX 225012 • DALLAS, TEXAS 75265

3-365

**TYPES SN5490A, SN5492A, SN5493A, SN54L90, SN54L93, SN54LS90, SN54LS92, SN54LS93, SN7490A, SN7492A, SN7493A, SN74LS90, SN74LS92, SN74LS93
DECADE, DIVIDE-BY-TWELVE, AND BINARY COUNTERS**

TTL DEVICES

PARAMETER MEASUREMENT INFORMATION

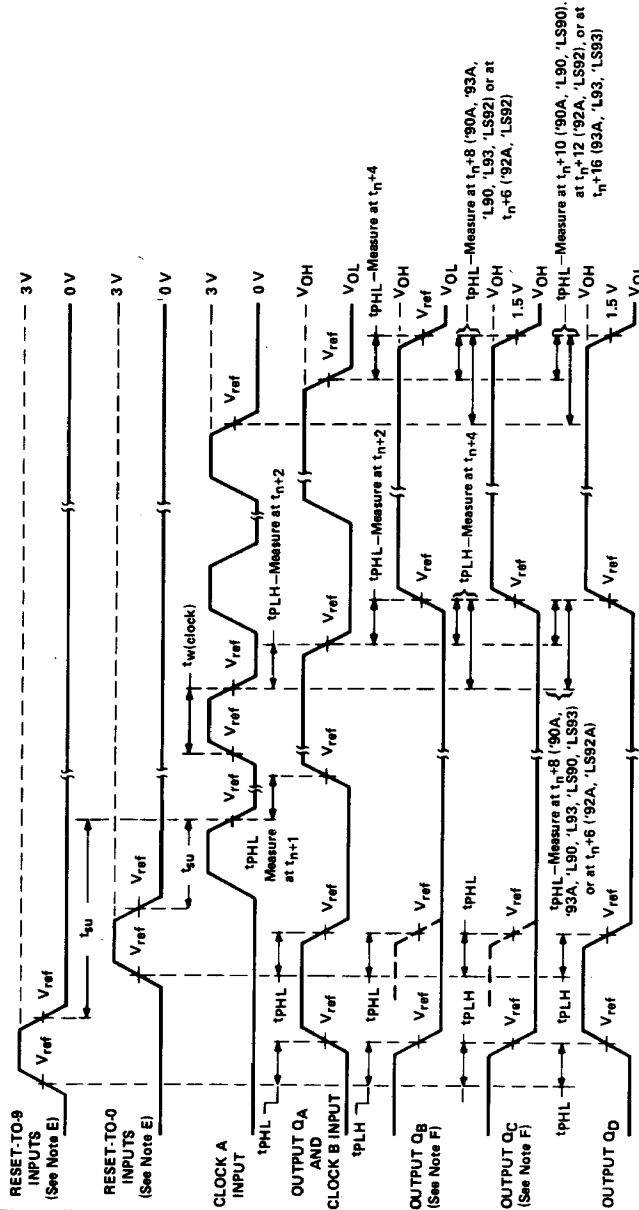

- NOTES: A. Input pulses are supplied by a generator having the following characteristics:
 for '90A, '92A, '93A, $t_r \leq 5$ ns, $t_f \leq 5$ ns, PRR = 1 MHz, duty cycle = 50%, $Z_{out} \approx 50$ ohms;
 for 'L90, 'L93, $t_r \leq 15$ ns, $t_f \leq 15$ ns, PRR = 500 kHz, duty cycle = 50%, $Z_{out} \approx 50$ ohms;
 for 'LS90, 'LS92, 'LS93, $t_r \leq 15$ ns, $t_f \leq 15$ ns, PRR = 1 MHz, duty cycle = 50%, $Z_{out} \approx 50$ ohms.
 B. C_L includes probe and jig capacitance.
 C. C1 (30 pF) is applicable for testing 'L90 and 'L93.
 D. All diodes are 1N3064 or equivalent.
 E. Each reset input is tested separately with the other reset at 4.5 V.
 F. Reference waveforms are shown with dashed lines.
 G. For '90A, '92A, and '93A: $V_{ref} = 1.5$ V. For 'L90, 'L93, 'LS90, 'LS92, and 'LS93: $V_{ref} = 1.3$ V.

FIGURE 1A

**TYPES SN5490A, SN5492A, SN5493A, SN54L90, SN54L93, SN54LS90, SN54LS92,
SN54LS93, SN7490A, SN7492A, SN7493A, SN74LS90, SN74LS92, SN74LS93
DECADE, DIVIDE-BY-TWELVE, AND BINARY COUNTERS**

PARAMETER MEASUREMENT INFORMATION

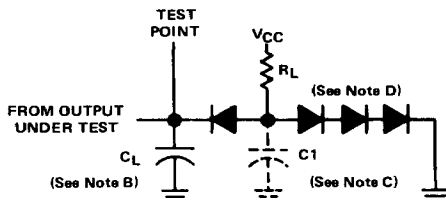

LOAD CIRCUIT

- NOTES: A. Input pulses are supplied by a generator having the following characteristics:
 for '90A, '92A, '93A, $t_r \leq 5$ ns, $t_f \leq 5$ ns, PRR = 1 MHz, duty cycle = 50%, $Z_{out} \approx 50$ ohms;
 for 'L90, 'L93, $t_r \leq 15$ ns, $t_f \leq 15$ ns, PRR = 500 kHz, duty cycle = 50%, $Z_{out} \approx 50$ ohms;
 for 'LS90, 'LS92, 'LS93, $t_r \leq 15$ ns, $t_f \leq 5$ ns, PRR = 1 MHz, duty cycle = 50%, $Z_{out} \approx 50$ ohms.
- B. C_L includes probe and jig capacitance.
- C. C_1 (30 pF) is applicable for testing 'L90 and 'L93.
- D. All diodes are 1N3064 or equivalent.
- E. Each reset input is tested separately with the other reset at 4.5 V.
- F. Reference waveforms are shown with dashed lines.
- G. For '90A, '92A, and '93A; $V_{ref} = 1.5$ V. For 'L90, 'L93, 'LS90, 'LS92, and 'LS93; $V_{ref} = 1.3$ V.

FIGURE 1B

3

TTL DEVICES

**TEXAS
INSTRUMENTS**

POST OFFICE BOX 225012 • DALLAS, TEXAS 75265

3-367