

TYPES SN5495A, SN54L95, SN54LS95B, SN7495A, SN74LS95B 4-BIT PARALLEL-ACCESS SHIFT REGISTERS

MARCH 1974 — REVISED DECEMBER 1983

TYPE	TYPICAL CLOCK FREQUENCY	TYPICAL POWER DISSIPATION
'95A	36 MHz	195 mW
'L95	5 MHz	19 mW
'LS95B	36 MHz	65 mW

description

These 4-bit registers feature parallel and serial inputs, parallel outputs, mode control, and two clock inputs. The registers have three modes of operation:

- Parallel (broadside) load
- Shift right (the direction Q_A toward Q_D)
- Shift left (the direction Q_D toward Q_A)

Parallel loading is accomplished by applying the four bits of data and taking the mode control input high. The data is loaded into the associated flip-flops and appears at the outputs after the high-to-low transition of the clock-2 input. During loading, the entry of serial data is inhibited.

Shift right is accomplished on the high-to-low transition of clock 1 when the mode control is low; shift left is accomplished on the high-to-low transition of clock 2 when the mode control is high by connecting the output of each flip-flop to the parallel input of the previous flip-flop (Q_D to input C, etc.) and serial data is entered at input D. The clock input may be applied commonly to clock 1 and clock 2 if both modes can be clocked from the same source. Changes at the mode control input should normally be made while both clock inputs are low; however, conditions described in the last three lines of the function table will also ensure that register contents are protected.

FUNCTION TABLE

MODE CONTROL		INPUTS				OUTPUTS						
		2 (L)	1 (R)	SERIAL	PARALLEL			Q_A	Q_B	Q_C	Q_D	
					A	B	C	D	Q_A	Q_B	Q_C	Q_D
H	H	X	X	X	X	X	X	X	Q_{A0}	Q_{B0}	Q_{C0}	Q_{D0}
H	↓	X	X	X	a	b	c	d	a	b	c	d
H	↓	X	X	X	$Q_B↑$	$Q_C↑$	$Q_D↑$	d	Q_{Bn}	Q_{Cn}	Q_{Dn}	d
L	L	H	X	X	X	X	X	X	Q_{A0}	Q_{B0}	Q_{C0}	Q_{D0}
L	X	↓	H	X	X	X	X	X	H	Q_{An}	Q_{Bn}	Q_{Cn}
L	X	↓	L	X	X	X	X	X	L	Q_{An}	Q_{Bn}	Q_{Cn}
↑	L	L	X	X	X	X	X	X	Q_{A0}	Q_{B0}	Q_{C0}	Q_{D0}
↓	L	L	X	X	X	X	X	X	Q_{A0}	Q_{B0}	Q_{C0}	Q_{D0}
↓	L	H	X	X	X	X	X	X	Q_{A0}	Q_{B0}	Q_{C0}	Q_{D0}
↑	H	L	X	X	X	X	X	X	Q_{A0}	Q_{B0}	Q_{C0}	Q_{D0}
↑	H	H	X	X	X	X	X	X	Q_{A0}	Q_{B0}	Q_{C0}	Q_{D0}

↑ Shifting left requires external connection of Q_B to A, Q_C to B, and Q_D to C. Serial data is entered at input D. H = high level (steady state), L = low level (steady state), X = irrelevant (any input, including transitions)

↓ = transition from high to low level, ↑ = transition from low to high level

a, b, c, d = the level of steady-state input at inputs A, B, C, or D, respectively.

Q_{A0} , Q_{B0} , Q_{C0} , Q_{D0} = the level of Q_A , Q_B , Q_C , or Q_D , respectively, before the indicated steady-state input conditions were established.

Q_{An} , Q_{Bn} , Q_{Cn} , Q_{Dn} = the level of Q_A , Q_B , Q_C , or Q_D , respectively, before the most-recent ↓ transition of the clock.

PRODUCTION DATA

This document contains information current as of publication date. Products conform to specifications per the terms of Texas Instruments standard warranty. Production processing does not necessarily include testing of all parameters.

**TEXAS
INSTRUMENTS**

POST OFFICE BOX 225012 • DALLAS, TEXAS 75265

SN5495A, SN54LS95B ... J OR W PACKAGE
SN7495A ... J OR N PACKAGE
SN74LS95B ... D, J OR N PACKAGE
(TOP VIEW)

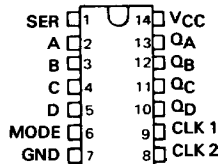

SN54L95 ... J PACKAGE
(TOP VIEW)

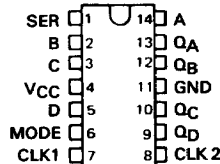

SN54LS95B ... FK PACKAGE
SN74LS95B ... FN PACKAGE
(TOP VIEW)

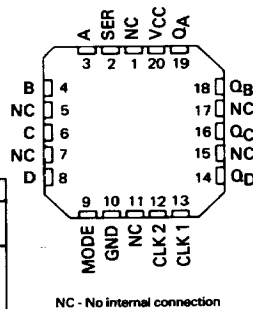

NC - No internal connection

3

TTL DEVICES

3-377

**TYPES SN5495A, SN54L95, SN54LS95B, SN7495A, SN74LS95B
4-BIT PARALLEL-ACCESS SHIFT REGISTERS**

logic diagrams



TTL DEVICES

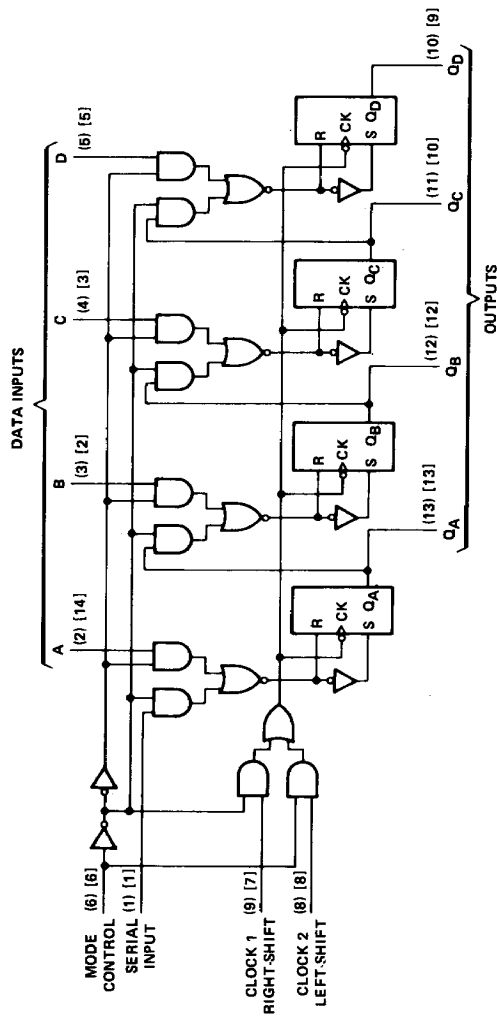

Pin numbers shown in () are for the 'LS95B and '95A and pin numbers shown in | | are for the 54L95.

3-378

TEXAS INSTRUMENTS

POST OFFICE BOX 225012 • DALLAS, TEXAS 75265

TYPES SN5495A, SN54L95, SN54LS95B, SN7495A, SN74LS95B 4-BIT PARALLEL-ACCESS SHIFT REGISTERS

schematics of inputs and outputs

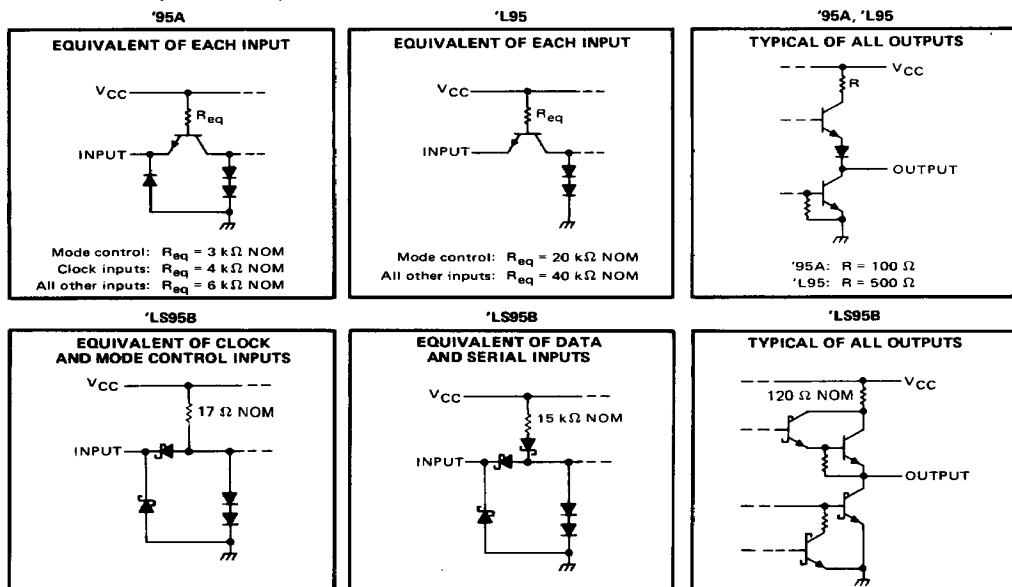

absolute maximum ratings over operating free-air temperature range (unless otherwise noted)

	SN54'	SN54L'	SN54LS'	SN74'	SN74LS'	UNIT
Supply voltage, V_{CC} (see Note 1)	7	8	7	7	7	V
Input voltage (see Note 2)	5.5	5.5	7	5.5	7	V
Interemitter voltage (see Note 3)	5.5	5.5		5.5		V
Operating free-air temperature range	- 55 to 125		0 to 70			$^{\circ}\text{C}$
Storage temperature range	- 65 to 150		- 65 to 150			$^{\circ}\text{C}$

- NOTES: 1. Voltage values, except interemitter voltage, are with respect to network ground terminal.
2. For the 'L95, input voltages must be zero or positive with respect to network ground terminal.
3. This is the voltage between two emitters of a multiple-emitter input transistor. This rating applies between the clock-2 input and the mode control input of the '95A and 'L95.

3

TTL DEVICES

**TEXAS
INSTRUMENTS**

POST OFFICE BOX 225012 • DALLAS, TEXAS 75285

3-379

TYPES SN5495A, SN7495A

4-BIT PARALLEL- SHIFT REGISTERS

recommended operating conditions

	SN5495A			SN7495A			UNIT
	MIN	NOM	MAX	MIN	NOM	MAX	
Supply voltage, V_{CC}	4.5	5	5.5	4.75	5	5.25	V
High-level output current, I_{OH}			-800			-800	μ A
Low-level output current, I_{OL}			16			16	mA
Clock frequency, f_{clock}		0	25		0	25	MHz
Width of clock pulse, $t_{w(clock)}$ (See Figure 1)	20			20			ns
Setup time, high-level or low-level data, t_{SU} (See Figure 1)	15			15			ns
Hold time, high-level or low-level data, t_H (See Figure 1)	0			0			ns
Time to enable clock 1, $t_{enable 1}$ (See Figure 2)	15			15			ns
Time to enable clock 2 (See Figure 2)	15			15			ns
Time to inhibit clock 1, $t_{inhibit 1}$ (See Figure 2)	5			5			ns
Time to inhibit clock 2 (See Figure 2)	5			5			ns
Operating free-air temperature, T_A	-55		125	0		70	$^{\circ}$ C

electrical characteristics over recommended operating free-air temperature range (unless otherwise noted)

PARAMETER		TEST CONDITIONS†	SN5495A			SN7495A			UNIT
			MIN	TYP‡	MAX	MIN	TYP‡	MAX	
V_{IH}	High-level input voltage		2			2			V
V_{IL}	Low-level input voltage				0.8			0.8	V
V_{IK}	Input clamp voltage	$V_{CC} = \text{MIN}, I_I = -12 \text{ mA}$			-1.5			-1.5	V
V_{OH}	High-level output voltage	$V_{CC} = \text{MIN}, V_{IH} = 2 \text{ V}, V_{IL} = 0.8 \text{ V}, I_{OH} = -800 \mu\text{A}$	2.4	3.4		2.4	3.4		V
V_{OL}	Low-level output voltage	$V_{CC} = \text{MIN}, V_{IH} = 2 \text{ V}, V_{IL} = 0.8 \text{ V}, I_{OL} = 16 \text{ mA}$		0.2	0.4		0.2	0.4	V
I_I	Input current at maximum input voltage	$V_{CC} = \text{MAX}, V_I = 5.5 \text{ V}$			1			1	mA
I_{IH}	High-level input current	Serial, A, B, C, D, Clock 1 or 2			40			40	μ A
		Mode control			80			80	
I_{IL}	Low-level input current	Serial, A, B, C, D, Clock 1 or 2			-1.6			-1.6	mA
		Mode control			-3.2			-3.2	
I_{OS}	Short-circuit output current§	$V_{CC} = \text{MAX}$	-18		-57	-18		-57	mA
I_{CC}	Supply current	$V_{CC} = \text{MAX}, \text{ See Note 4}$		39	63		39	63	mA

†For conditions shown as MIN or MAX, use the appropriate value specified under recommended operating conditions.

‡All typical values are at $V_{CC} = 5 \text{ V}, T_A = 25^{\circ}\text{C}$.

§Not more than one output should be shorted at a time.

NOTE 4: I_{CC} is measured with all outputs and serial input open; A, B, C, and D inputs grounded; mode control at 4.5 V; and a momentary 3 V, then ground, applied to both clock inputs.

switching characteristics, $V_{CC} = 5 \text{ V}, T_A = 25^{\circ}\text{C}$

PARAMETER		TEST CONDITIONS	MIN	TYP	MAX	UNIT
f_{max}	Maximum clock frequency	$C_L = 15 \text{ pF}, R_L = 400 \Omega,$ See Figure 1	25	36		MHz
t_{PLH}	Propagation delay time, low-to-high-level output from clock			18	27	ns
t_{PHL}	Propagation delay time, high-to-low-level output from clock			21	32	ns

TYPES SN54L95 4-BIT PARALLEL-ACCESS SHIFT REGISTERS

recommended operating conditions

		SN54L95			UNIT	
		MIN	NOM	MAX		
V _{CC}	Supply voltage	4.5	5	5.5	V	
V _{IH}	High-level input voltage	2			V	
V _{IL}	Low-level input voltage				0.7	V
I _{OH}	High-level output current				-0.1	mA
I _{OL}	Low-level output current				2	mA
f _{clock}	Clock frequency	0			3	MHz
t _{w(clock)}	Width of clock pulse (See Figure 1)	200				ns
t _{su}	Setup time (See Figure 1)	High-level data		100		ns
		Low-level data		120		ns
t _h	Hold time, high-level or low-level data (See Figure 1)	0				ns
t _{enable 1}	Time to enable clock 1 (See Figure 2)	225				ns
t _{enable 2}	Time to enable clock 2 (See Figure 2)	200				ns
t _{inhibit 1}	Time to inhibit clock 1 (See Figure 2)	100				ns
t _{inhibit 2}	Time to inhibit clock 2 (See Figure 2)	0				ns
T _A	Operating free-air temperature	-55		125		°C

electrical characteristics over recommended operating free-air temperature range (unless otherwise noted)

PARAMETER		TEST CONDITIONS †				SN54L95			UNIT
						MIN	TYP ‡	MAX	
V _{OH}		V _{CC} = MIN, V _{IH} = 2 V, V _{IL} = 0.7 V, I _{OH} = -0.1 mA				2.4	3.3		V
V _{OL}		V _{CC} = MIN, V _{IH} = 2 V, V _{IL} = 0.7 V, I _{OL} = 2 mA				0.15 0.3			V
I _I	Serial, A, B, C, D, Clock 1 or 2	V _{CC} = MAX, V _I = 5.5 V				0.1			mA
	Mode control					0.2			
I _{IH}	Serial, A, B, C, D, Clock 1 or 2	V _{CC} = MAX, V _I = 2.4 V				10			μA
	Mode control					20			
I _{IL}	Serial, A, B, C, D, Clock 1 or 2	V _{CC} = MAX, V _{IL} = 0.3 V				-0.18			mA
	Mode control					-0.36			
I _{OS} §		V _{CC} = MAX				-3	-15		mA
I _{CC}		V _{CC} = MAX, See Note 4				3.8	9		mA

† For conditions shown as MIN or MAX, use the appropriate value specified under recommended operating conditions.

‡ All typical values are at V_{CC} = 5 V, T_A = 25°C.

§ Not more than one output should be shorted at a time.

NOTE 4: I_{CC} is measured with all outputs and serial input open; A, B, C, and D inputs grounded; mode control at 4.5 V; and a momentary 3 V, then ground, applied to both clock inputs.

switching characteristics, V_{CC} = 5 V, T_A = 25°C

PARAMETER	FROM (INPUT)	TO (OUTPUT)	TEST CONDITIONS		MIN	TYP	MAX	UNIT
f _{max}	Any	Any	R _L = 4 kΩ	C _L = 50 pF	3	5		MHz
t _{PLH}					115	200		ns
t _{PHL}					125	200		ns

3

TTL DEVICES

TEXAS INSTRUMENTS

POST OFFICE BOX 225012 • DALLAS, TEXAS 75265

3-381

TYPES SN54LS95B, SN74LS95B

4-BIT PARALLEL-ACCESS SHIFT REGISTERS

recommended operating conditions

	SN54LS95B			SN74LS95B			UNIT
	MIN	NOM	MAX	MIN	NOM	MAX	
Supply voltage, V_{CC}	4.5	5	5.5	4.75	5	5.25	V
High-level output current, I_{OH}			-400			-400	μ A
Low-level output current, I_{OL}			4			8	mA
Clock frequency, f_{clock}	0		25	0		25	MHz
Width of clock pulse, $t_w(\text{clock})$ (see Figure 1)	20			20			ns
Setup time, high-level or low-level data, t_{SU} (see Figure 1)	20			20			ns
Hold time, high-level or low-level data, t_H (see Figure 1)	20			10			ns
Time to enable clock 1, $t_{enable 1}$ (see Figure 2)	20			20			ns
Time to enable clock 2, $t_{enable 2}$ (see Figure 2)	20			20			ns
Time to inhibit clock 1, $t_{inhibit 1}$ (see Figure 2)	20			20			ns
Time to inhibit clock 2, $t_{inhibit 2}$ (see Figure 2)	20			20			ns
Operating free-air temperature, T_A	-55		125	0		70	$^{\circ}$ C

electrical characteristics over recommended operating free-air temperature range (unless otherwise noted)

PARAMETER	TEST CONDITIONS [†]	SN54LS95B			SN74LS95B			UNIT
		MIN	TYP [‡]	MAX	MIN	TYP [‡]	MAX	
V_{IH} High-level input voltage		2			2			V
V_{IL} Low-level input voltage				0.7			0.8	V
V_{IK} Input clamp voltage	$V_{CC} = \text{MIN}, I_I = -18 \text{ mA}$			-1.5			-1.5	V
V_{OH} High-level output voltage	$V_{CC} = \text{MIN}, V_{IH} = 2 \text{ V}, V_{IL} = V_{IL \text{ max}}, I_{OH} = -400 \mu\text{A}$	2.5	3.4		2.7	3.4		V
V_{OL} Low-level output voltage	$V_{CC} = \text{MIN}, V_{IH} = 2 \text{ V}, V_{IL} = V_{IL \text{ max}}$			0.25	0.4	0.25	0.4	V
						0.35	0.5	
I_I Input current at maximum input voltage	$V_{CC} = \text{MAX}, V_I = 7 \text{ V}$			0.1			0.1	mA
I_{IH} High-level input current	$V_{CC} = \text{MAX}, V_I = 2.7 \text{ V}$			20			20	μ A
I_{IL} Low-level input current	$V_{CC} = \text{MAX}, V_I = 0.4 \text{ V}$			-0.4			-0.4	mA
I_{OS} Short-circuit output current [§]	$V_{CC} = \text{MAX}$	-20		-100	-20		-100	mA
I_{CC} Supply current	$V_{CC} = \text{MAX},$ See Note 4		13	21		13	21	mA

[†]For conditions shown as MIN or MAX, use the appropriate value specified under recommended operating conditions.

[‡]All typical values are at $V_{CC} = 5 \text{ V}, T_A = 25^{\circ}\text{C}$.

[§]Not more than one output should be shorted at a time, and duration of the short-circuit should not exceed one second.

NOTE 4: I_{CC} is measured with all outputs and serial input open; A, B, C, and D inputs grounded; mode control at 4.5 V; and a momentary 3 V, then ground, applied to both clock inputs.

switching characteristics, $V_{CC} = 5 \text{ V}, T_A = 25^{\circ}\text{C}$

PARAMETER	TEST CONDITIONS	MIN	TYP	MAX	UNIT
f_{max} Maximum clock frequency	$C_L = 15 \text{ pF}, R_L = 2 \text{ k}\Omega,$ See Figure 1	25	36		MHz
t_{PLH} Propagation delay time, low-to-high-level output from clock		18	27		ns
t_{PHL} Propagation delay time, high-to-low-level output from clock		21	32		ns

TYPES SN5495A, SN54L95, SN54LS95B, SN7495A, SN74LS95B 4-BIT PARALLEL-ACCESS SHIFT REGISTERS

PARAMETER MEASUREMENT INFORMATION

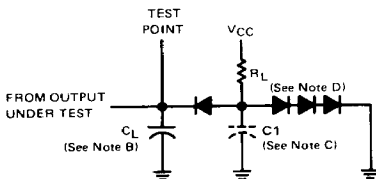

LOAD CIRCUIT

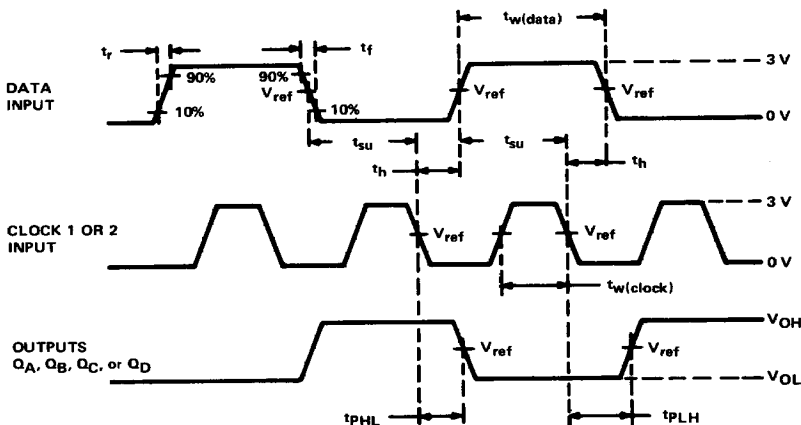

- NOTES: A. Input pulses are supplied by a generator having the following characteristics: $t_r \leq 10$ ns, $t_f \leq 10$ ns, and $Z_{out} \approx 50 \Omega$. For the data pulse generator, PRR = 500 kHz; for the clock pulse generator, PRR = 1 MHz. When testing t_{max} , vary PRR. For '95A, $t_w(data) \geq 20$ ns; $t_w(clock) \geq 15$ ns. For 'L95, $t_w(data) \geq 150$ ns; $t_w(clock) \geq 200$ ns. For 'LS95B, $t_w(data) \geq 20$ ns, $t_w(clock) \geq 15$ ns.
- B. C_L includes probe and jig capacitance.
- C. C_1 (30 pF) is applicable for testing 'L95.
- D. All diodes are 1N3064 equivalent.
- E. For '95A, $V_{ref} = 1.5$ V; for 'L95 and 'LS95B, $V_{ref} = 1.3$ V.

VOLTAGE WAVEFORMS
FIGURE 1-SWITCHING TIMES

TYPES SN5495A, SN54L95, SN54LS95B, SN7495A, SN74LS95B
4-BIT PARALLEL-ACCESS SHIFT REGISTERS

PARAMETER MEASUREMENT INFORMATION

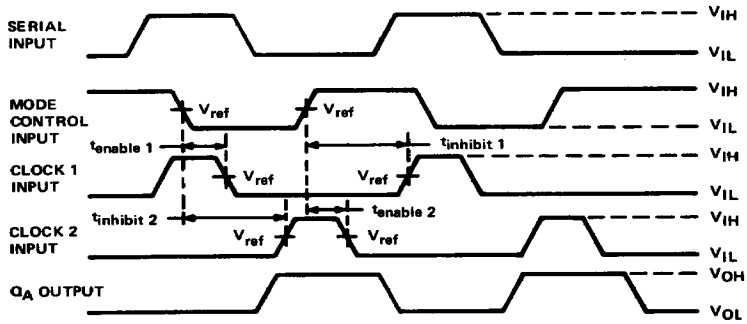

NOTES: A. Input A is at a low level.
 B. For '95A, $V_{ref} = 1.5\ V$; for 'L95 and 'LS95B, $V_{ref} = 1.3\ V$.

VOLTAGE WAVEFORMS
FIGURE 2-CLOCK ENABLE/INHIBIT TIMES

3

TTL DEVICES