

## CURRENT MODE PWM CONTROLLER WITH BUILT-IN HIGH VOLTAGE MOSFET

### DESCRIPTION

SD484XP67K65 is a current mode PWM controller with low standby power and low start current for power switch. In standby mode, the circuit enters burst mode to reduce the standby power dissipation.

The switch frequency is 67KHz with  $\pm 2.5$  KHz jitter frequency for low EMI.

SD484XP67K65 includes under voltage lock-out, over voltage protection, leading edge blanking, over current protection and the temperature protection. The circuit will restart automatically until the system is normal after the protection is active.

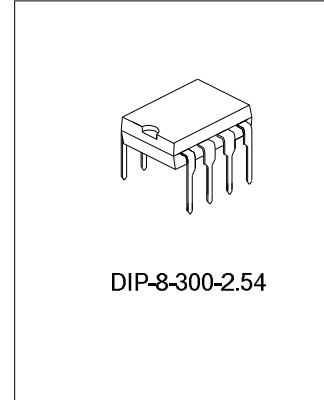

### FEATURES

- \* Lower start-up current (Typ.6 $\mu$ A)
- \* Frequency jitter for low EMI
- \* Overcurrent protection
- \* Overvoltage protection
- \* Undervoltage lockout
- \* Built-in temperature protection
- \* Built-in high voltage MOSFET
- \* Auto restart mode
- \* Burst mode operation
- \* Cycle by cycle current limit

### APPLICATIONS

- \* Switch power

**ORDERING INFORMATION**

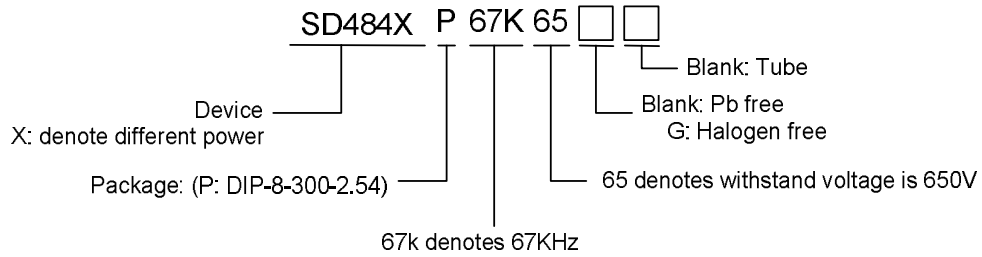

Part No.	Package	Marking	Material	Package Type
SD4840P67K65	DIP-8-300-2.54	SD4840P67K65	Pb free	Tube
SD4840P67K65G		SD4840P67K65G	Halogen free	Tube
SD4841P67K65		SD4841P67K65	Pb free	Tube
SD4841P67K65G		SD4841P67K65G	Halogen free	Tube
SD4842P67K65		SD4842P67K65	Pb free	Tube
SD4842P67K65G		SD4842P67K65G	Halogen free	Tube
SD4843P67K65		SD4843P67K65	Pb free	Tube
SD4843P67K65G		SD4843P67K65G	Halogen free	Tube
SD4844P67K65		SD4844P67K65	Pb free	Tube
SD4844P67K65G		SD4844P67K65G	Halogen free	Tube

**TYPICAL OUPUT POWER CAPABILITY**

Part No.	190~265VAC		85~265VAC	
	Adapter	Open	Adapter	Open
SD4840P67K65	7W	9W	5W	7.2W
SD4840P67K65G	7W	9W	5W	7.2W
SD4841P67K65	10W	14W	8W	12W
SD4841P67K65G	10W	14W	8W	12W
SD4842P67K65	12W	17W	10W	14W
SD4842P67K65G	12W	17W	10W	14W
SD4843P67K65	14W	19W	12W	15W
SD4843P67K65G	14W	19W	12W	15W
SD4844P67K65	16W	21W	14W	18W
SD4844P67K65G	16W	21W	14W	18W

**BLOCK DIAGRAM**

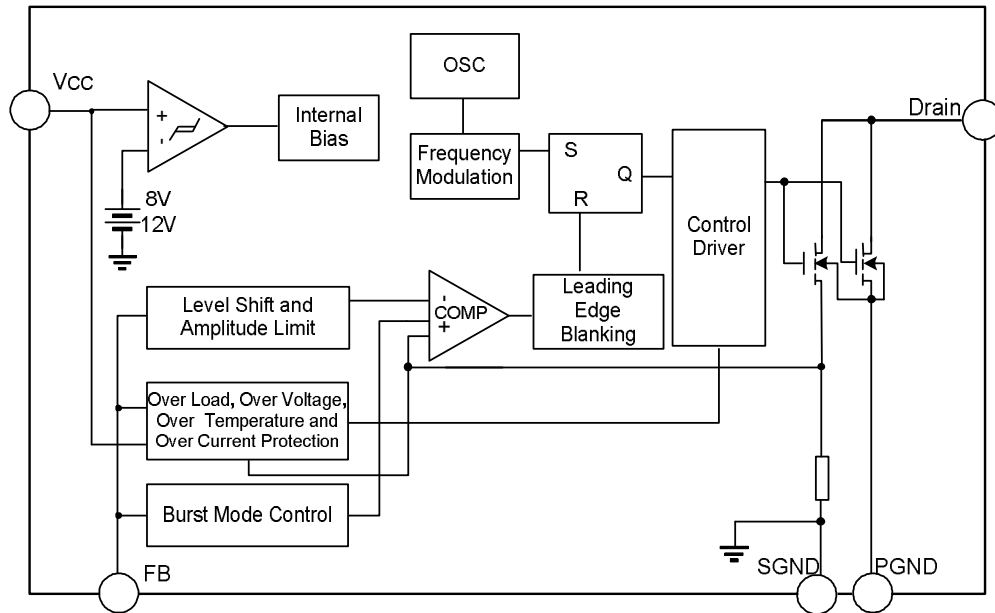

**ABSOLUTE MAXIMUM RATING**

Characteristics	Symbol	Rating	Unit	
Drain-Gate Voltage (RGS=1M $\Omega$ )	V <sub>DGR</sub>	650	V	
Gate-Source (GND) Voltage	V <sub>GS</sub>	$\pm$ 30	V	
Drain Current Pulse (note1)	I <sub>DM</sub>	SD4840P67K65	4	A
		SD4841P67K65	6	
		SD4842P67K65	8	
		SD4843P67K65	11	
		SD4844P67K65	14	
Continuous Drain Current (T <sub>amb</sub> =25 $^{\circ}$ C)	I <sub>D</sub>	SD4840P67K65	1	A
		SD4841P67K65	1.5	
		SD4842P67K65	2	
		SD4843P67K65	3	
		SD4844P67K65	4	
Signal Pulse Avalanche Energy(note 2)	E <sub>AS</sub>	SD4840P67K65	15	mJ
		SD4841P67K65	30	
		SD4842P67K65	68	
		SD4843P67K65	140	
		SD4844P67K65	200	
Power Supply Voltage	V <sub>CC,MAX</sub>	21	V	

Characteristics	Symbol	Rating	Unit
Analog Input Voltage	VFB	-0.3~ VSD	V
Total Power Dissipation	PD	1.5	W
	Darting	0.017	W/°C
Operating Junction Temperature	TJ	+160	°C
Operating Temperature	Tamb	-25~ +85	°C
Storage Temperature	TSTG	-55~+150	°C

Note: 1. Pulse width is limited by maximum junction temperature.

2. L=51mH, starting T<sub>J</sub>=25°C

**ELECTRICAL CHARACTERISTICS** (sense MOSFET part, unless otherwise specified, Tamb=25°C)

Characteristics		Symbol	Test conditions	Min.	Typ.	Max.	Unit
Drain-Source Breakdown Voltage		BVDSS	VGS=0V, ID=50μA	650	--	--	V
Zero Gate Voltage Drain Current		IDSS	VDS=Max. VGS=0V	--	--	50	μA
			VDS=0.8Max. VGS=0V Tamb=125°C	--	--	200	μA
Static Drain-Source On Resistance	SD4840P67K65	RDS(ON)	VGS=10V, ID=0.5A	--	14.0	16.8	Ω
	SD4841P67K65			--	8.0	9.6	
	SD4842P67K65			--	5.0	6.0	
	SD4843P67K65			--	4.0	4.8	
	SD4844P67K65			--	3.0	3.6	
Input Capacitance	SD4840P67K65	Ciss	VGS=0V, VDS=25V, f=1MHz	--	210	--	pF
	SD4841P67K65			--	250	--	
	SD4842P67K65			--	550	--	
	SD4843P67K65			--	640	--	
	SD4844P67K65			--	840	--	
Output Capacitance	SD4840P67K65	Coss	VGS=0V, VDS=25V, f=1MHz	--	18	--	pF
	SD4841P67K65			--	25	--	
	SD4842P67K65			--	38	--	
	SD4843P67K65			--	40	--	
	SD4844P67K65			--	44	--	
Reverse Transfer Capacitance	SD4840P67K65	Crss	VGS=0V, VDS=25V, f=1MHz	--	8	--	pF
	SD4841P67K65			--	10	--	
	SD4842P67K65			--	17	--	
	SD4843P67K65			--	30	--	
	SD4844P67K65			--	40	--	
Turn On Delay Time	SD4840P67K65	td(ON)	VDD=0.5BVDSS, ID=25mA	--	10	--	nS
	SD4841P67K65			--	12	--	
	SD4842P67K65			--	20	--	
	SD4843P67K65			--	33	--	
	SD4844P67K65			--	40	--	

Characteristics		Symbol	Test conditions	Min.	Typ.	Max.	Unit
Rise Time	SD4840P67K65	tr	V <sub>DD</sub> =0.5V <sub>DSS</sub> , I <sub>D</sub> =25mA	--	3	--	nS
	SD4841P67K65			--	4	--	
	SD4842P67K65			--	15	--	
	SD4843P67K65			--	19	--	
	SD4844P67K65			--	25	--	
Turn Off Delay Time	SD4840P67K65	td(OFF)	V <sub>DD</sub> =0.5V <sub>DSS</sub> , I <sub>D</sub> =25mA	--	27	--	nS
	SD4841P67K65			--	30	--	
	SD4842P67K65			--	55	--	
	SD4843P67K65			--	70	--	
	SD4844P67K65			--	90	--	
Fall Time	SD4840P67K65	tf	V <sub>DD</sub> =0.5V <sub>DSS</sub> , I <sub>D</sub> =25mA	--	8	--	nS
	SD4841P67K65			--	10	--	
	SD4842P67K65			--	25	--	
	SD4843P67K65			--	32	--	
	SD4844P67K65			--	42	--	

**ELECTRICAL CHARACTERISTICS** (unless otherwise specified, T<sub>amb</sub>=25°C)

Characteristics		Symbol	Test conditions	Min.	Typ.	Max.	Unit
<b>Undervoltage Section</b>							
Start Threshold Voltage		V <sub>start</sub>		11	12	13	V
Stop Threshold Voltage		V <sub>stop</sub>		7	8	9	V
<b>Oscillator Section</b>							
Oscillate Frequency		F <sub>OSC</sub>		61	67	73	KHz
Frequency Jitter		F <sub>MOD</sub>		±1.5	±2.0	±2.5	KHz
Frequency Change With Temperature		--	25°C ≤ T <sub>amb</sub> ≤ +85°C	--	±5	±10	%
Maximum Duty Cycle		D <sub>max</sub>		72	77	82	%
<b>Feedback Section</b>							
Feedback Source Current		I <sub>FB</sub>	0V ≤ V <sub>FB</sub> ≤ 3V	0.7	0.9	1.1	mA
Shutdown Feedback Voltage		V <sub>SD</sub>		5.5	6.0	6.5	V
Shutdown Delay Current		I <sub>delay</sub>	5V ≤ V <sub>FB</sub> ≤ V <sub>SD</sub>	3.5	5.0	6.5	μA
<b>Current Limit</b>							
Peak Current Limit	SD4840P67K65	I <sub>over</sub>	Max. inductor current	0.53	0.60	0.67	A
	SD4841P67K65			0.67	0.75	0.83	
	SD4842P67K65			0.80	0.90	1.00	
	SD4843P67K65			1.10	1.20	1.30	
	SD4844P67K65			1.35	1.50	1.65	
<b>Burst mode</b>							
Burst Mode High Voltage		V <sub>BURH</sub>		0.4	0.5	0.6	V
Burst Mode Low Voltage		V <sub>BURL</sub>		0.25	0.35	0.45	V

Characteristics	Symbol	Test conditions	Min.	Typ.	Max.	Unit
<b>Protection Section</b>						
Overvoltage Protection	$V_{ovp}$		18	19	--	V
Thermal Shutdown	$T_{sd}$		125	140	--	°C
Leading-edge Blanking Time	TLEB		200	--	--	ns
<b>Total Standby Current</b>						
Start Current	$I_{start}$	VCC=11V	--	6	20	μA
Supply Current (Control Part)	$I_{op}$	VCC=12V	1	3	5	mA

### PIN CONFIGURATION

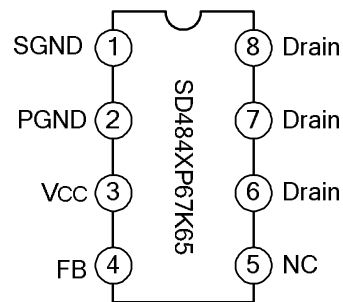

### PIN DESCRIPTION

Pin No.	Pin Name	I/O	Function description
1	SGND	-	Ground for control part.
2	PGND	-	MOSFET Ground.
3	Vcc	-	Power supply pin.
4	FB	I/O	Feedback input pin.
5	NC	-	Not connected.
6,7,8	Drain	O	Drain pins.

## FUNCTION DESCRIPTION

SD484XP67K65 is designed for off-line SMPS, consisting of high voltage MOSFET, optimized gate driver and current mode PWM controller which includes frequency oscillator and various protections such as undervoltage lockout, overvoltage protection, overcurrent protection and overtemperature protection. Frequency jitter generated from oscillator is used to lower EMI. Burst mode is adopted during light load to lower standby power dissipation, and function of lead edge blanking eliminates the MOSFET error shutdown caused by interference through minimizing MOSFET turning on time. Few peripheral components are needed for higher efficiency and higher reliability and it is suitable for flyback converter and forward converter.

### 1. Under Voltage Lockout and Self-Start

At the beginning, the capacitor connected to pin VCC is charged via start resistor by high voltage AC and the circuit start to work if voltage at Vcc is 12V. The output is shutdown if there is any protection during normal operation and Vcc is decreased because of powering of auxiliary winding. The whole control circuit is shutdown if voltage at Vcc is 8V below to lower current dissipation and the capacitor is recharged for restarting.

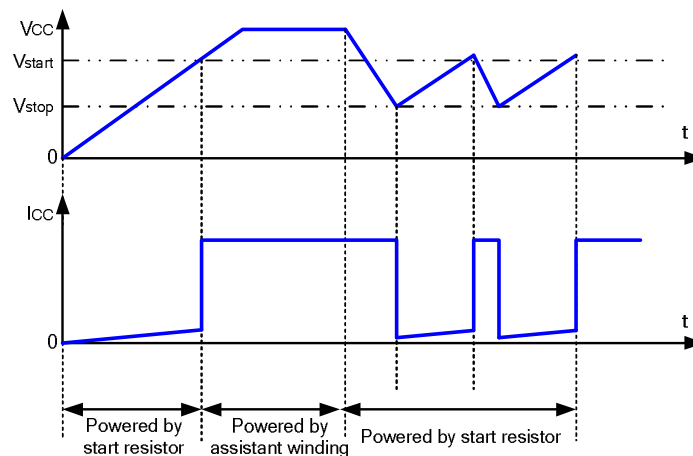

### 2. Frequency Jitter

The oscillation frequency is kept changed for low EMI and decreasing radiation on one frequency. The oscillation frequency changes within a very small range to simplify EMI design. The rule of frequency changing: change from 65KHz to 69KHz.

### 3. Light Load Mode

Working in this mode to reduce power dissipation. It works normally when FB is 500mV above and during  $350\text{mV} < \text{FB} < 500\text{mV}$ , there are two different conditions: when FB changes from low to high, there is no action for switch and it is the same with condition of FB lower than 350mV; the other is that FB changes from high to low, comparison value is increased for increasing turning on time to decrease switch loss.

For this mode, during FB changes from high to low, the output voltage increases (increasing speed is decided by load) because of the high comparison value to decrease FB until it is 350mV below; when  $\text{FB} < 350\text{mV}$ , there is no action for switch and output voltage decrease (decreasing speed is also decided by load) to increase FB.

This is repeated to decrease action of switch for lower power dissipation.

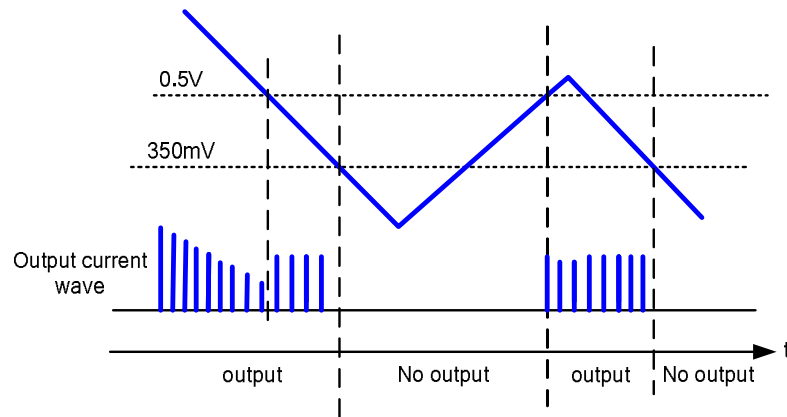

#### 4. Leading Edge Blanking

For this current-controlled circuit, there is pulse peak current during the transient of switch turning on and there is an error operation if the current is sampled during this time. And leading edge blanking is adopted to eliminate this error operation. The output of PWM comparator is used for controlling shutdown after the leading edge blanking if there is any output drive.

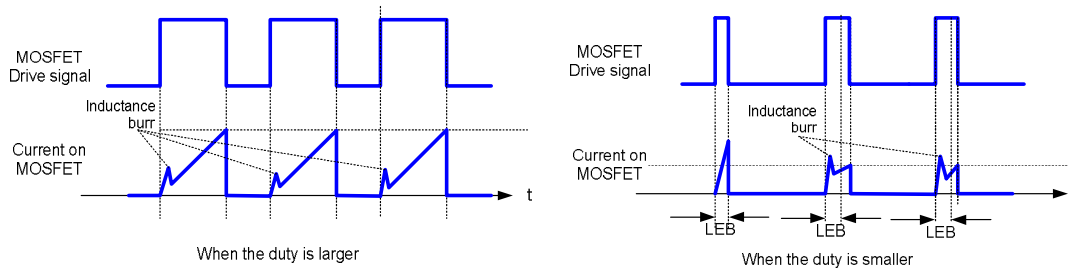

#### 5. Over Voltage Protection

The output is shutdown if voltage at  $V_{cc}$  exceeds the threshold and this state is kept until the circuit is powered on reset.

#### 6. Overload Protection

FB voltage increase if there is overload and the output is shutdown when FB voltage is up to the feedback shutdown voltage. This state is kept until the circuit is powered on reset.

#### 7. Peak Current Limit Cycle By Cycle

During each cycle, the peak current value is decided by the comparison value of the comparator, which will not exceed the peak current limited value to guarantee the current on MOSFET will not be more than the rating current. The output power will not increase if the current reaches the peak value to limit the max. output power. The output voltage decreases and FB voltage increases if there is overload and corresponding protection occurs.



## 8. Abnormal Over Current Protection

That secondary diode is short, or the transformer is short will cause this event. At this time, once it is over current in spite of the leading edge blanking (L.E.B) time, protection will begin after 350nS, and is active for every cycle. When the voltage on the current sense resistor is 1.6V, this protection will occur and the output is shut down. This state is kept until the under voltage occurs, and the circuit will start.

## 9. Thermal Shutdown

If the circuit is over temperature, the over temperature protection will shut down the output to prevent the circuit from damage. This state is kept until the under voltage occurs, and the circuit will start.

## TYPICAL APPLICATION CIRCUIT

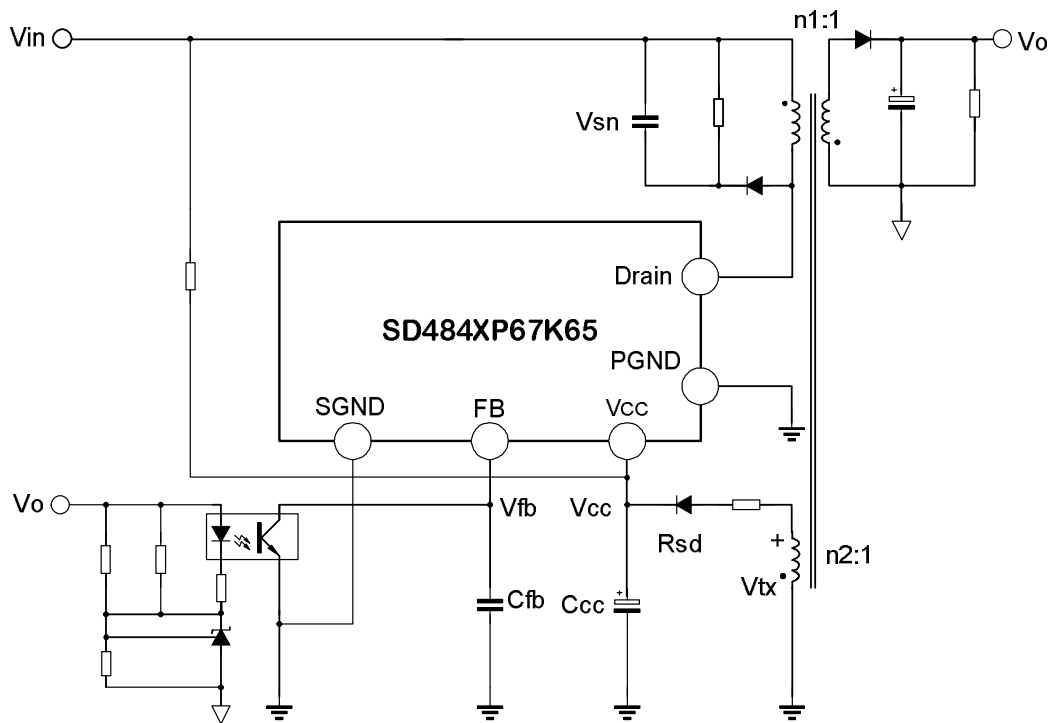

Note:

1. The circuit and parameters are for reference only, please set the parameters of the real application circuit based on the real test.
2. Better not to place VCC winding as inner coil.

PACKAGE OUTLINE

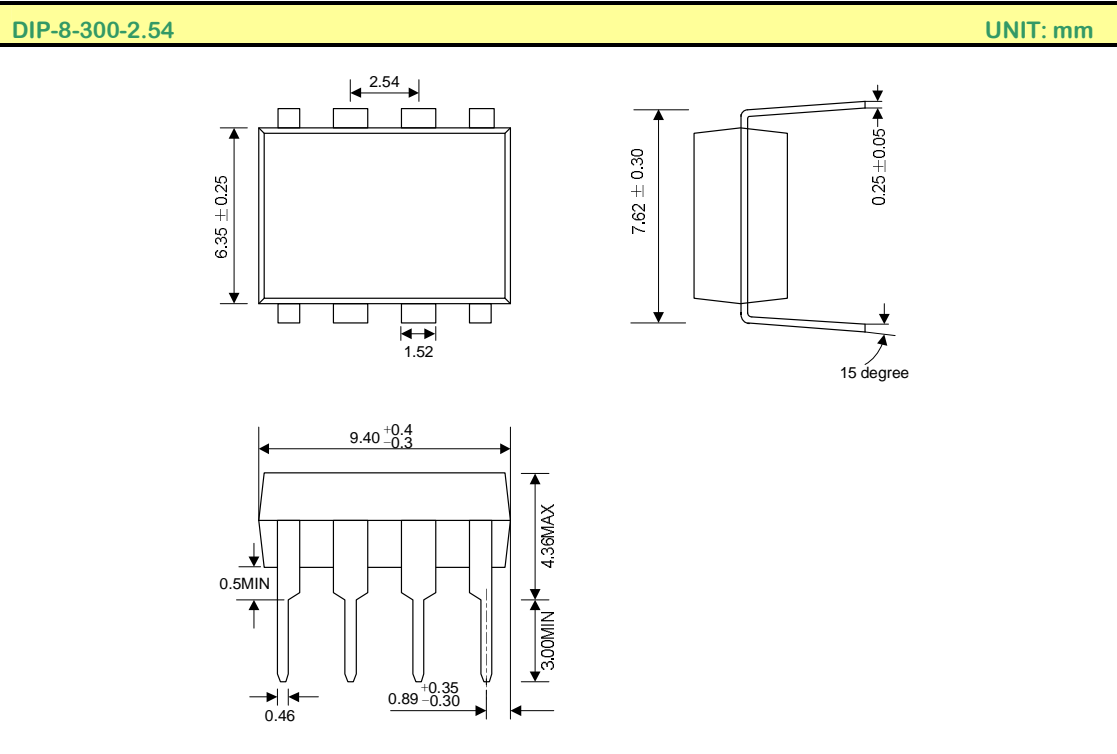

**MOS DEVICES OPERATE NOTES:**

Electrostatic charges may exist in many things. Please take following preventive measures to prevent effectively the MOS electric circuit as a result of the damage which is caused by discharge:

- The operator must put on wrist strap which should be earthed to against electrostatic.
- Equipment cases should be earthed.
- All tools used during assembly, including soldering tools and solder baths, must be earthed.
- MOS devices should be packed in antistatic/conductive containers for transportation.

**Disclaimer :**

- Silan reserves the right to make changes to the information herein for the improvement of the design and performance without further notice!
- All semiconductor products malfunction or fail with some probability under special conditions. When using Silan products in system design or complete machine manufacturing, it is the responsibility of the buyer to comply with the safety standards strictly and take essential measures to avoid situations in which a malfunction or failure of such Silan products could cause loss of body injury or damage to property.
- Silan will supply the best possible product for customers!