

## MC33286

### AUTOMOTIVE DUAL HIGH SIDE DRIVER

SEMICONDUCTOR  
TECHNICAL DATA



**DW SUFFIX**  
SO20WB Package  
CASE 751D-05

## Advance Information

# Automotive Dual High Side Driver

This device is a dual high side power switch dedicated for automotive applications. In comparison with mechanical relays, this device offers higher reliability as well as protection and diagnostic features.

The device consists of two independent 35mΩ R<sub>dson</sub> switches in a surface mount package. It can be directly interfaced with a microcontroller for control and diagnostic functions. The device is fully protected against overcurrents, short-circuits and incorporates an overtemperature shutdown. It can be directly and continuously supplied by the battery and offers a very low quiescent current in standby mode.

- Designed for Automotive Applications
- Junction Temperature Range from -40°C to 150°C
- Operating Voltage Range from 8V to 40V
- Maximum Breakdown Voltage greater than 40V
- Surface Mount Package
- 35mΩ R<sub>dson</sub> at 25°C
- Overtemperature Protection with Hysteresis
- Under Voltage Shutdown
- Reverse Battery protected
- Open Load Detection in On-State
- Diagnostic Output
- ESD Protection 2kV
- Current Limitation at 30A
- Loss of ground protected
- Standby Current less than 10μA at V<sub>bat</sub> = 14V

### PIN ASSIGNMENT

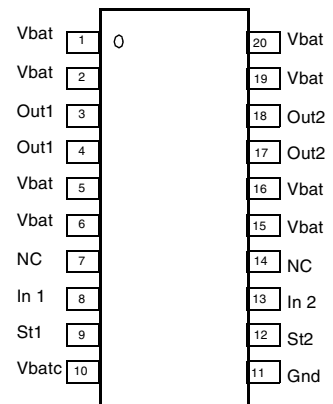

### ORDERING INFORMATION

Device	Operating Temperature Range	Package
PC33286DW	TA=-40° to +125°C	SO20

### Simplified Application Schematic

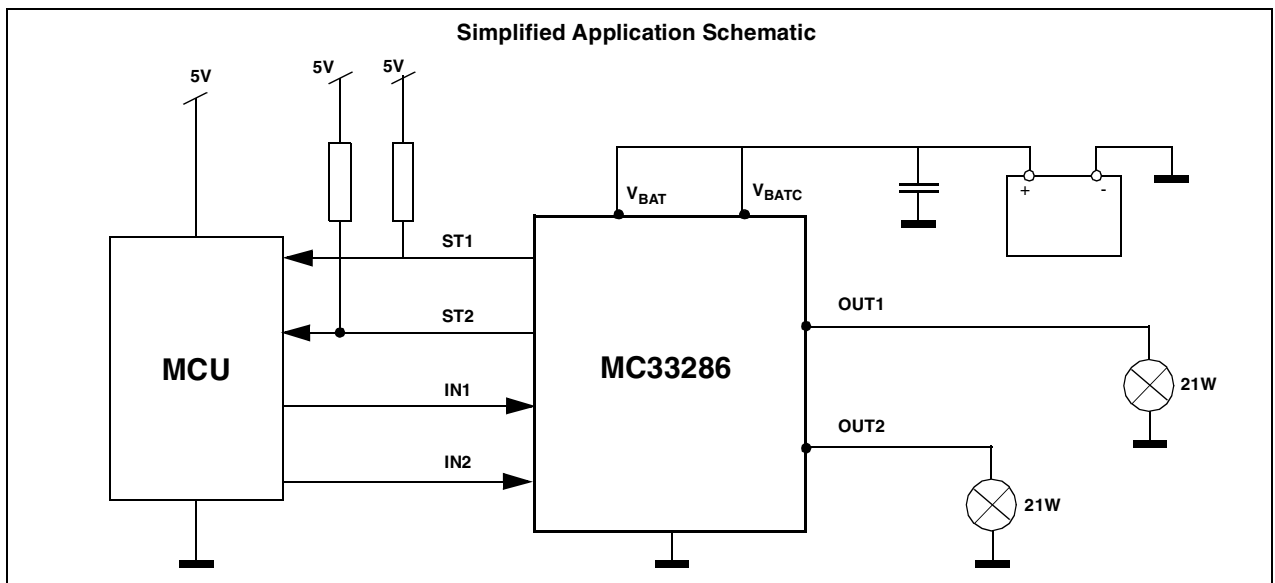

This document contains information on a new product. Specifications and information herein are subject to change without notice.

## MAXIMUM RATINGS

Ratings	Symbol	Value	Unit
V <sub>bat</sub> and V <sub>batc</sub> Voltage : Continuous/Pulse	V <sub>bat</sub>	-0.3 to 40	V
OUT1, OUT2 Voltage with Respect to Gnd : Continuous/Pulse	V <sub>out</sub>	-0.3 to 40	V
OUT1, OUT2 to V <sub>btap</sub> Voltage : Continuous	V <sub>out</sub>	40	V
St1, St2 Voltage : Continuous/Pulse	V <sub>st</sub>	-0.3 to 5.5	V
IN1, IN2 Voltage : Continuous/Pulse	V <sub>in</sub>	-0.3 to 10	V
In1, In2, St1, St2 Current	I <sub>in</sub>	+/-4	mA
ESD all Pins	V <sub>esd</sub>	+/-2000	V
OUT1, OUT2 DC Output Current	I <sub>out</sub>	6	A
OUT1, OUT2 Pulse Current (Note 1)	I <sub>outp</sub>	30	A

## THERMAL RATINGS

Junction Temperature	T <sub>j</sub>	-40 to 150	°C
Storage Temperature	T <sub>st</sub>	-65 to 150	°C
Thermal Resistance Junction to Ambient (note 2)	R <sub>thja</sub>	70	°C/W

**NOTES :** 1. During lamps inrush current. Value internally limited.  
2. Device mounted with minimum pcb dimensions.

**ELECTRICAL CHARACTERISTICS** T<sub>j</sub> from -40°C to +125°C, V<sub>bat</sub> from 8V to 16V, unless otherwise noted. Typical values reflect approximate mean at 25°C, V<sub>bat</sub>=12V, at time of device characterization.

Description	Symbol	Characteristics			Unit	Conditions
		Min	Typ	Max		
Operating Voltage	V <sub>bat</sub>	8		40	V	
Under Voltage Threshold	V <sub>uv</sub>		7	8	V	
Drain-Source on Resistance	R <sub>dson</sub>		25	35	mΩ	V <sub>bat</sub> > 9V ; T <sub>j</sub> = 25°C
Drain-Source on Resistance	R <sub>dson</sub>		35	50	mΩ	V <sub>bat</sub> > 9V ; T <sub>j</sub> = 150°C
High Current Limitation	I <sub>limh</sub>		30		A	V <sub>OUT</sub> > 1V
Short-Circuit Current Limitation	I <sub>liml</sub>		10		A	V <sub>OUT</sub> < 1V, T <sub>j</sub> = 25°C
Body Diode Forward Voltage	V <sub>f</sub>		0.7		V	I <sub>out</sub> = -2A, T <sub>j</sub> = 25°C
Body Diode Forward Voltage	V <sub>f</sub>		0.6		V	I <sub>out</sub> = -2A, T <sub>j</sub> = 125°C
Hot Open Load Current	I <sub>ol</sub>		400	700	mA	Device in On State
Standby Current	I <sub>stdby</sub>			10	μA	V <sub>bat</sub> < 14V ; V <sub>in</sub> < 0.8V
Supply Current : One Channel On	I <sub>on1</sub>			10	mA	In1 or In2 in High State
Supply Current : Both Channels On	I <sub>on2</sub>			20	mA	In1 and In2 in High State
Low Input Voltage	V <sub>il</sub>			1.5	V	
High Input Voltage	V <sub>ih</sub>	3.5			V	
Input Hysteresis	V <sub>hyst</sub>	0.4	0.7	0.9	V	
Input Current	I <sub>ih</sub>		20	100	μA	V <sub>in</sub> = 3.5V
Status Voltage	V <sub>status</sub>			0.5	V	I <sub>st</sub> = 1mA ; Output in Fault
Thermal Shutdown	T <sub>shut</sub>	150			°C	
Thermal Shutdown Hysteresis	T <sub>hyst</sub>		20		°C	
Output Maximum Positive Slew Rate	S <sub>rpout</sub>	0.05	0.2	0.5	V/μs	Load = 6Ω, V <sub>bat</sub> = 12V
Output Maximum Negative Slew Rate	S <sub>rmout</sub>	0.15	0.8	1.5	V/μs	Load = 6Ω, V <sub>bat</sub> = 12V
PWM frequency	f <sub>PWM</sub>			150	Hz	
Turn-on Delay Time	t <sub>don</sub>		100	150	μs	In=2.5V to 10% V <sub>out</sub> , V <sub>bat</sub> =12V

# MC33286

**ELECTRICAL CHARACTERISTICS**  $T_j$  from  $-40^{\circ}\text{C}$  to  $+125^{\circ}\text{C}$ ,  $V_{\text{bat}}$  from 8V to 16V, unless otherwise noted. Typical values reflect approximate mean at  $25^{\circ}\text{C}$ ,  $V_{\text{bat}}=12\text{V}$ , at time of device characterization.

Description	Symbol	Characteristics			Unit	Conditions
		Min	Typ	Max		
Turn-off Delay Time	$t_{\text{doff}}$		100	150	$\mu\text{s}$	$\text{IN} = 2.5\text{V to } 90\% V_{\text{out}}$ , $V_{\text{bat}}=12\text{V}$
Open Load to Status Low Delay Time	$T_{\text{OL}}$		10		$\mu\text{s}$	

## FUNCTIONAL TRUTH TABLE

Conditions	IN1	IN2	OUT1	OUT2	St1	St2
Normal Operation	L	L	L	L	H	H
	H	L	H	L	H	H
	L	H	L	H	H	H
	H	H	H	H	H	H
Undervoltage	X	X	L	L	H	H
Overtemperature Channel 1	H	X	L	X	L	H
Overtemperature Channel 2	X	H	X	L	H	L
Overtemperature Channel 1/Channel 2	H	H	L	L	L	L
Open Load Channel 1	H	X	H	X	L	H
Open Load Channel 2	X	H	X	H	H	L
Overcurrent Channel 1	H	X	X	X	H	H
Overcurrent Channel 2	X	H	X	X	H	H

L = 'Low level' ; H = 'High level' ; X = 'don't care'

Figure 1. Application Schematic

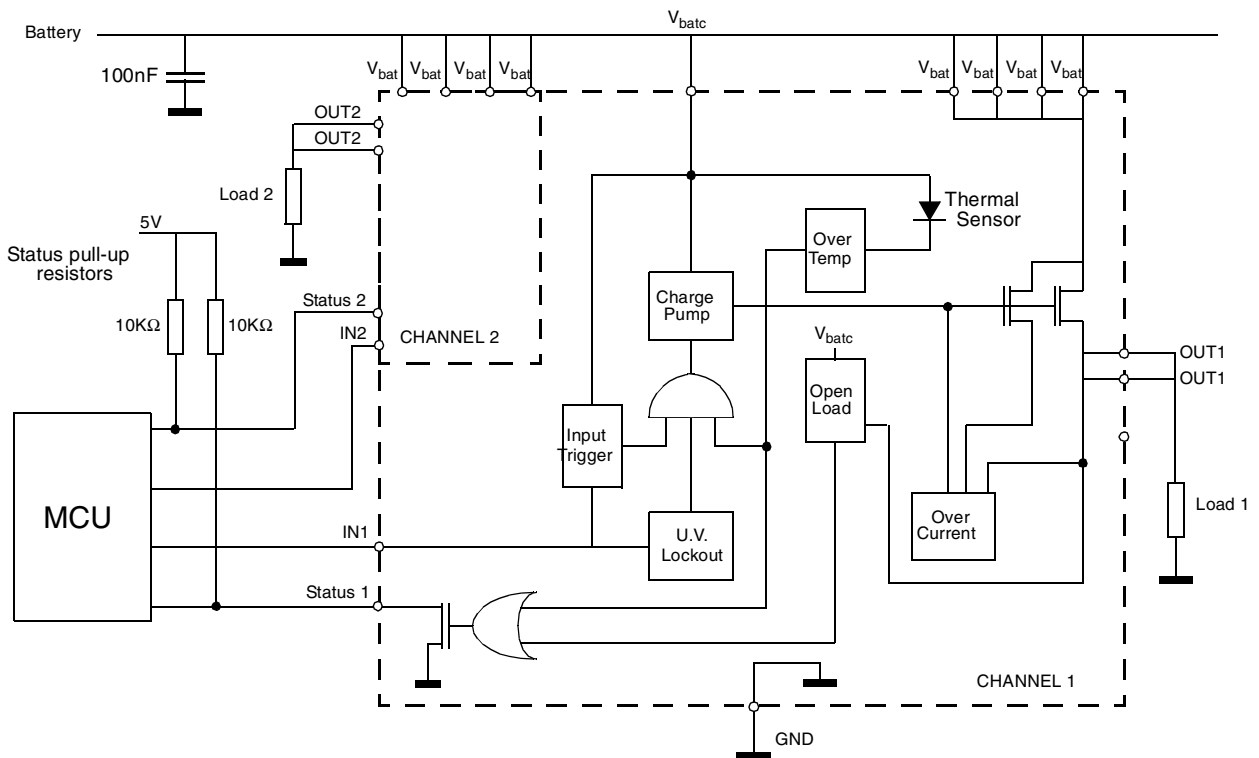

MC33286  
PIN FUNCTION DESCRIPTION

Pin No.	Name/Function	Description
1, 2, 5, 6, 15, 16, 19, 20	V <sub>bat</sub> Supply Voltage	These are the power supply pins of the device. These pins are directly connected with the lead frame of the package and are tied to the drain of the switching MOSFET. These pins can be directly connected to the battery voltage. In addition to their supply functions, these pins participate to the thermal behaviour of the device in conducting the heat from the switching MOSFET to the printed circuit board.
3, 4, 18, 17	OUT1 OUTPUT Channel 1 OUT 2 OUTPUT Channel 2	Pins 3 and 4 are the output 1 terminals. Pins 17 and 18 are the output 2 terminals. They are directly connected to the source of the power MOSFET. The R <sub>dson</sub> is 35mΩ max per output at 25°C. Its value increases up to 50mΩ at 150°C junction temperature.
8, 13	IN 1 INPUT Channel 1 IN 2 INPUT Channel 2	These are the device input pins, which directly control their associated output. The thresholds are CMOS compatible. When the input is in low state, the associated output MOSFET is off. When input is high, the MOSFET is turned on and the load is activated. When both inputs are low, the device is in standby mode and its supply current is less than 1mA for V <sub>bat</sub> up to 12V.
9, 12	St1 Status for Channel 1 St2 Status for Channel 2	These pins are the channel 1 and 2 status. Their internal structure is an open drain with an internal clamp at 6V. An external pull up connected to the 5V is needed. When the device is in normal condition the status is high. If open load or overtemperature occurs on one channel, the associated output status will be pulled low. See Functional Truth Table.
10	V <sub>batc</sub> VBAT Control	This pin is the supply voltage pin for the control portion of the device. It has to be connected to the V <sub>bat</sub> line and to the other V <sub>bat</sub> pins listed above. An internal 45V zener diode is connected between pin 10 and Gnd.
11	GND GROUND	This is the Gnd pin of the device.

## General Information

This device is a dual high side power switch dedicated for automotive applications. In comparison with mechanical relays, this device offers higher reliability as well as protection and diagnostic features. It has been designed to be directly connected to the battery voltage.

In the future, the number of electronic switches directly connected to the battery will increase, so the MC33286 includes a special input trigger and architecture which allows to have a very low standby current when the  $V_{bat}$  is lower than 12V.

The MC33286 concept uses a dual chip approach packaged in a single SO20 package. This low power package can be used because the ON resistance of the switch (35m $\Omega$  max at 25°C) guarantees a low power dissipation (less than 300mW) when driving two 21Watts lamps. The two chips are internally connected by die to die wire bonding to allow the transfer of analog and control information between the two dice.

The two chips are the Control and Power dice.

The Control chip uses the SMARTMOS3.5NMV technology. The two channels of this control chip are totally symmetrical and independant. It drives the gate of the output power MOSFET and manages the analog information from the power MOSFET die to ensure power device protection.

The Power chip uses the HDTMOS3 technology. It has one independent sources plus current sensing cells for open load detection and current limitation. In addition, a thermal sensor (diode) is located in the middle of each source to protect the MC33286 against overtemperature. The drain of the Power die is connected to the battery voltage by the lead frame of the package. This lead frame has been especially developed and has eight pins connected together to the  $V_{bat}$ . These pins are used as the  $V_{bat}$  connection as well as thermal path.

## Supply Voltage

The MC33286 can be directly connected to the  $V_{bat}$  line. Figure 4 shows the supply voltage characteristics. The  $V_{batc}$  ( $V_{bat}$  of Control die, pin 10) and  $V_{batp}$  ( $V_{bat}$  of power die, pins 1, 2, 5, 6, 15, 16, 19, 20) are not internally connected, so the  $V_{bat}$  and  $V_{batc}$  have to be connected externally by the printed circuit board.

## Under Voltage

Figure 4 also shows the supply voltage characteristic when one or two sides of the MC33286 are turned on. From 0V to undervoltage level (7V typical), all blocks of the MC33286 are not totally supplied. The undervoltage threshold value versus temperature is shown in Figure 2. The under voltage function allows the turn-off of the output transistor, because the  $V_{bat}$  voltage will be not enough to guarantee the full on state of the output transistor due to an incomplete drive of the gate. When the  $V_{bat}$  is greater than the undervoltage threshold, the supply current increases due to the charge pump start up and MOSFET driver activation.

## Reverse Battery Protection

When a negative battery voltage arises, the current flows in a reverse direction from the source region to drain region of both of the MosFets through the body diode. The limitation is then the temperature reached by the junction, which is linked to the thermal impedance from the junction to the ambient.

## Input Trigger

The MC33286 has a special input trigger circuitry allowing the device to have less than 0.5 $\mu$ A typical standby current. When the input level is below 1.5V, the circuit is in sleep mode (see Figure 4).

## Status Output

The output status is an open drain structure, active at low level, so an external pull-up resistor is required to read the status information.

The status indicates the open load and the over temperature information. The output short-circuit, current limitation and  $V_{bat}$  undervoltage are not reported on the status pin. But an output short-circuit to Gnd will be detected by an overtemperature because the total power dissipation of the device will make it reach the thermal detection.

## Open Load Function

The open load detection is active during the ON phase (Hot open load detection). An amplifier measures the differential voltage between  $V_{bat}$  and  $V_{out}$  (this value is typically 400mA) at 25°C.

An open load condition will create a voltage lower than 12mV and the open load circuitry will detect it and will pull down the status output. If the open load condition is present before the device turn-on, the status will be pulled down after a delay due to the rise time of the output.

## Overcurrent Function (High Current Limitation)

The device incorporates a current limitation at 30 Amps typical when outputs are loaded ( $V_{out} > 1V$ ). A 21 Watts lamp has a nominal current of about 2 amp and at turn on, the MC33286 has to drive a peak current of about 12A, as the lamp inrush current is about six times the nominal DC current. A standard current limitation set up at 30A will not being activated during the inrush current of one lamp but will protect the circuit against overcurrent. Figure 3 shows the overcurrent threshold versus temperature.

## Short Circuit Protection (Low Current Limitation)

During a hard short-circuit to Gnd, the power dissipation would be 30A x 14V = 420 Watts if only the overcurrent limitation exists. The thermal protection will be activated and switch the device off. Nevertheless the peak power dissipation and energy is quite high.

Therefore, a short circuit protection has been implemented and is activated when the output voltage is lower than about 1V. As shown in the Figure 5, the low current limitation decreases with temperature. In the case of a short circuit, the power dissipated in the device decreases with time due to the decay of the current limitation with temperature.

## Overtemperature Function

The overtemperature function uses a thermal sensor located in the middle of each output power HDTMOS transistor. The sensor is a diode connected to  $V_{bat}$  in the power die. The diode forward voltage varies of -2mV/°C. So, by measuring the diode voltage the power output MOSFET temperature is monitored. This diode voltage information is transferred to the control die and compared to a reference voltage generated from the band gap reference generator. When the temperature reaches the overtemp threshold, the circuit is turned off. As the input voltage is still high, the circuit is not in wake mode but the current consumption decreases due to the turn-off of the charge pump. The overtemperature

comparator has an hysteresis which maintains the device off. As soon as the die power temperature decreases by around 20°C the device automatically switches on again.

If the cause of the overtemperature has not been removed, it is likely that the device will reach the overtemperature shutdown again and will cycle off and on until the overtemperature cause is removed. As soon as the device switches off, due to overtemperature, the status pin is pulled low to inform the microcontroller that an abnormal condition has occurred.

**Figure 2. Undervoltage Threshold Versus Temperature**

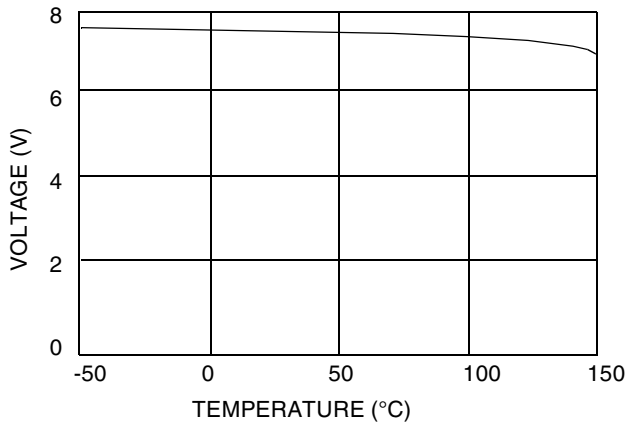

**Figure 3. High Current Limitation Versus Temperature**

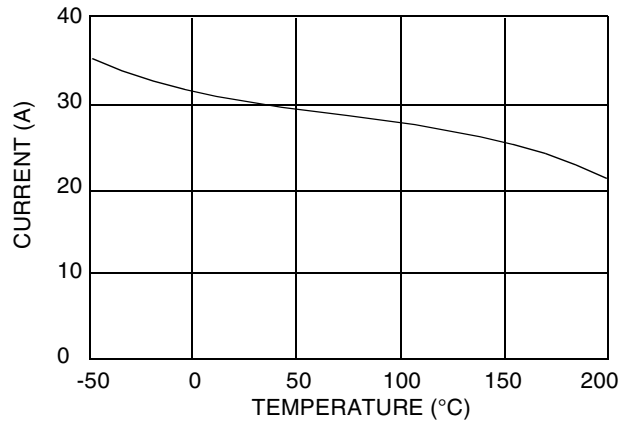

**Figure 4. Battery Supply Current Versus Vbat**

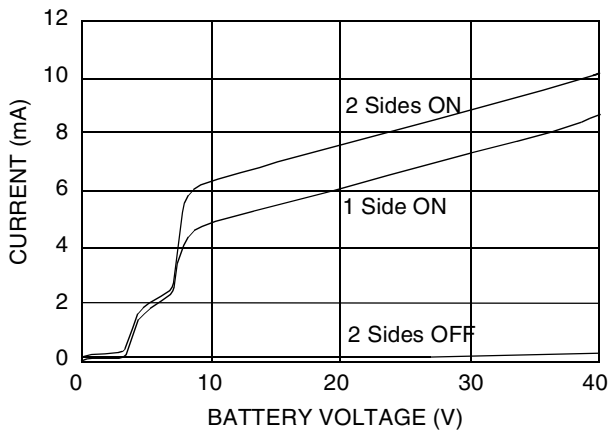

**Figure 5. Short Circuit Current Limitation Versus Temperature**

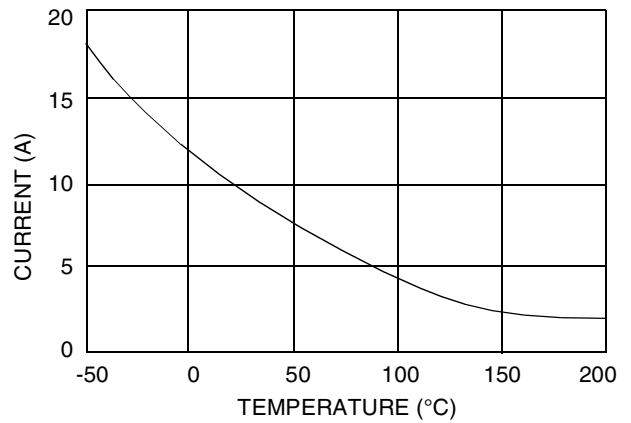

**Figure 6. OpenLoad Current Threshold Versus Temperature**

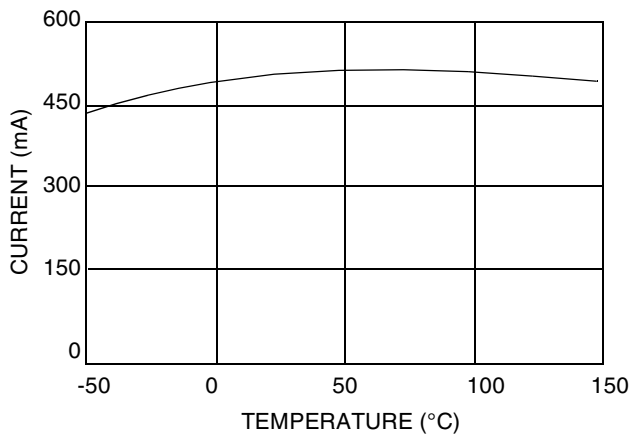

**Figure 7. Ron Versus Temperature**

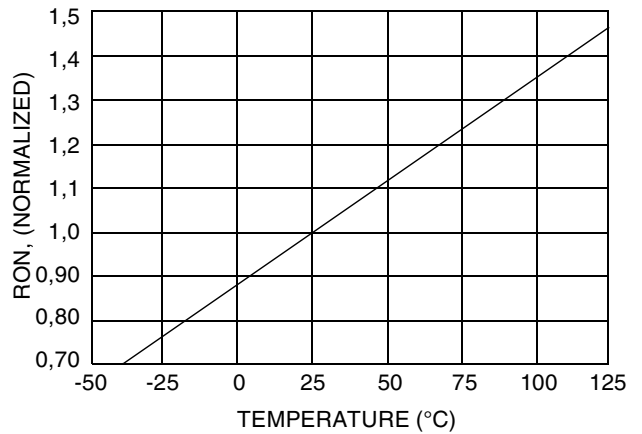

Motorola reserves the right to make changes without further notice to any products herein. Motorola makes no warranty, representation or guarantee regarding the suitability of its products for any particular purpose, nor does Motorola assume any liability arising out of the application or use of any product or circuit, and specifically disclaims any and all liability, including without limitation consequential or incidental damages. "Typical" parameters which may be provided in Motorola data sheets and/or specifications can and do vary in different applications and actual performance may vary over time. All operating parameters, including "Typical" must be validated for each customer application by customer's technical experts. Motorola does not convey any license under its patent rights nor the rights of others. Motorola products are not designed, intended, or authorized for use as components in systems intended for surgical implant into the body, or other applications intended to support or sustain life, or for any application in which the failure of the Motorola product could create a situation where personal injury or death may occur. Should Buyer purchase or use Motorola products for any such unintended or unauthorized application, Buyer shall indemnify and hold Motorola and its officers, employees, subsidiaries, affiliates, and distributors harmless against all claims, costs, damages, and expenses, and reasonable attorney fees arising out of, directly or indirectly, any claim of personal injury or death associated with such unintended or un authorized use, even if such claim alleges that Motorola was negligent regarding the design or manufacture of the parts. Motorola and  are registered trademarks of Motorola, Inc. Motorola, Inc. is an Equal Employment Opportunity/Affirmative Action Employer.

**How to reach us:**

**USA / EUROPE / Locations Not Listed:** Motorola Literature Distribution;  
P.O. Box 5405, Denver, Colorado 80217. 1-303-675-2140 or 1-800-441-2447

**JAPAN:** Motorola Japan Ltd.; SPS, Technical Information Center, 3-20-1,  
Minami-Azabu, Minato-ku, Tokyo 106-8573 Japan. 81-3-344-3569

**Technical Information Center: 1-800-521-6274**

**ASIA / PACIFIC:** Motorola Semiconductors H.K. Ltd.; Silicon Harbour Centre,  
2, Dai King Street, Tai Po Industrial Estate, Tai Po, N.T., Hong Kong.  
852-26668334

**HOME PAGE:** <http://www.motorola.com/semiconductors>

