

LM137/LM337 3-Terminal Adjustable Negative Regulators

General Description

The LM137/LM337 are adjustable 3-terminal negative voltage regulators capable of supplying in excess of $-1.5A$ over an output voltage range of $-1.2V$ to $-37V$. These regulators are exceptionally easy to apply, requiring only 2 external resistors to set the output voltage and 1 output capacitor for frequency compensation. The circuit design has been optimized for excellent regulation and low thermal transients. Further, the LM137 series features internal current limiting, thermal shutdown and safe-area compensation, making them virtually blowout-proof against overloads.

The LM137/LM337 serve a wide variety of applications including local on-card regulation, programmable-output voltage regulation or precision current regulation. The LM137/LM337 are ideal complements to the LM117/LM317 adjustable positive regulators.

Features

- Output voltage adjustable from $-1.2V$ to $-37V$
- $1.5A$ output current guaranteed, $-55^{\circ}C$ to $+150^{\circ}C$
- Line regulation typically $0.01\%/V$
- Load regulation typically 0.3%
- Excellent thermal regulation, $0.002\%/W$

- 77 dB ripple rejection
- Excellent rejection of thermal transients
- 50 ppm/ $^{\circ}C$ temperature coefficient
- Temperature-independent current limit
- Internal thermal overload protection
- P* Product Enhancement tested
- Standard 3-lead transistor package
- Output is short circuit protected

LM137 Series Packages and Power Capability

Device	Package	Rated Power Dissipation	Design Load Current
LM137/337	TO-3 (K) TO-39 (H)	20W 2W	1.5A 0.5A
LM337	TO-220 (T)	15W	1.5A
LM337	SOT-223 (MP)	2W	1A

Typical Applications

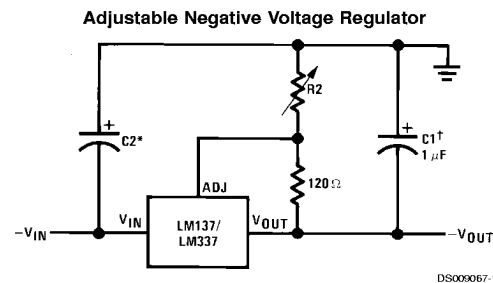

Full output current not available at high input-output voltages

$$-V_{OUT} = -1.25V \left(1 + \frac{R_2}{120} \right) + (-I_{ADJ} \times R_2)$$

[†]C1 = $1 \mu F$ solid tantalum or $10 \mu F$ aluminum electrolytic required for stability

^{*}C2 = $1 \mu F$ solid tantalum is required only if regulator is more than 4" from power-supply filter capacitor

Output capacitors in the range of $1 \mu F$ to $1000 \mu F$ of aluminum or tantalum electrolytic are commonly used to provide improved output impedance and rejection of transients

Comparison between SOT-223 and D-Pak (TO-252) Packages

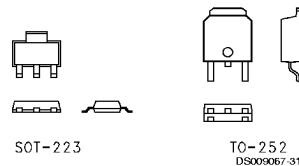

Absolute Maximum Ratings (Notes 4, 1)

If Military/Aerospace specified devices are required, please contact the National Semiconductor Sales Office/Distributors for availability and specifications.

Power Dissipation	Internally Limited
Input-Output Voltage Differential	40V
Operating Junction Temperature Range	-55°C to +150°C
LM137	

LM337	0°C to +125°C
Storage Temperature	-65°C to +150°C
Lead Temperature (Soldering, 10 sec.)	300°C
Plastic Package (Soldering, 4 sec.)	260°C
ESD Rating	2k Volts

Electrical Characteristics

(Note 1)

Parameter	Conditions	LM137			LM337			Units
		Min	Typ	Max	Min	Typ	Max	
Line Regulation	$T_j = 25^\circ\text{C}$, $3\text{V} \leq V_{\text{IN}} - V_{\text{OUT}} \leq 40\text{V}$ (Note 2) $I_L = 10\text{ mA}$		0.01	0.02		0.01	0.04	%/V
Load Regulation	$T_j = 25^\circ\text{C}$, $10\text{ mA} \leq I_{\text{OUT}} \leq I_{\text{MAX}}$		0.3	0.5		0.3	1.0	%
Thermal Regulation	$T_j = 25^\circ\text{C}$, 10 ms Pulse		0.002	0.02		0.003	0.04	%/W
Adjustment Pin Current			65	100		65	100	μA
Adjustment Pin Current Charge	$10\text{ mA} \leq I_L \leq I_{\text{MAX}}$ $3.0\text{V} \leq V_{\text{IN}} - V_{\text{OUT}} \leq 40\text{V}$, $T_A = 25^\circ\text{C}$		2	5		2	5	μA
Reference Voltage	$T_j = 25^\circ\text{C}$ (Note 3) $3\text{V} \leq V_{\text{IN}} - V_{\text{OUT}} \leq 40\text{V}$, (Note 3) $10\text{ mA} \leq I_{\text{OUT}} \leq I_{\text{MAX}}$, $P \leq P_{\text{MAX}}$	-1.225	-1.250	-1.275	-1.213	-1.250	-1.287	V
		-1.200	-1.250	-1.300	-1.200	-1.250	-1.300	V
Line Regulation	$3\text{V} \leq V_{\text{IN}} - V_{\text{OUT}} \leq 40\text{V}$, (Note 2)		0.02	0.05		0.02	0.07	%/V
Load Regulation	$10\text{ mA} \leq I_{\text{OUT}} \leq I_{\text{MAX}}$, (Note 2)		0.3	1		0.3	1.5	%
Temperature Stability	$T_{\text{MIN}} \leq T_j \leq T_{\text{MAX}}$		0.6			0.6		%
Minimum Load Current	$ V_{\text{IN}} - V_{\text{OUT}} \leq 40\text{V}$ $ V_{\text{IN}} - V_{\text{OUT}} \leq 10\text{V}$		2.5	5		2.5	10	mA
			1.2	3		1.5	6	mA
Current Limit	$ V_{\text{IN}} - V_{\text{OUT}} \leq 15\text{V}$ K and T Package H Package $ V_{\text{IN}} - V_{\text{OUT}} = 40\text{V}$, $T_j = 25^\circ\text{C}$ K and T Package H Package	1.5	2.2	3.5	1.5	2.2	3.7	A
		0.5	0.8	1.8	0.5	0.8	1.9	A
		0.24	0.4		0.15	0.4		A
		0.15	0.17		0.10	0.17		A
RMS Output Noise, % of V_{OUT}	$T_j = 25^\circ\text{C}$, 10 Hz $\leq f \leq 10\text{ kHz}$		0.003			0.003		%
Ripple Rejection Ratio	$V_{\text{OUT}} = -10\text{V}$, $f = 120\text{ Hz}$ $C_{\text{ADJ}} = 10\ \mu\text{F}$		60			60		dB
		66	77		66	77		dB
Long-Term Stability	$T_j = 125^\circ\text{C}$, 1000 Hours		0.3	1		0.3	1	%
Thermal Resistance, Junction to Case	H Package		12	15		12	15	$^\circ\text{C/W}$
	K Package		2.3	3		2.3	3	$^\circ\text{C/W}$
	T Package					4		$^\circ\text{C/W}$
Thermal Resistance, Junction to Ambient (No Heat Sink)	H Package		140			140		$^\circ\text{C/W}$
	K Package		35			35		$^\circ\text{C/W}$
	T Package					50		$^\circ\text{C/W}$

Note 1: Unless otherwise specified, these specifications apply $-55^\circ\text{C} \leq T_j \leq +150^\circ\text{C}$ for the LM137, $0^\circ\text{C} \leq T_j \leq +125^\circ\text{C}$ for the LM337; $V_{\text{IN}} - V_{\text{OUT}} = 5\text{V}$; and $I_{\text{OUT}} = 0.1\text{A}$ for the TO-39 package and $I_{\text{OUT}} = 0.5\text{A}$ for the TO-3, SOT-223 and TO-220 packages. Although power dissipation is internally limited, these specifications are applicable for power dissipations of 2W for the TO-39 and SOT-223 (see Application Hints), and 20W for the TO-3, SOT-223 and TO-220. I_{MAX} is 1.5A for the TO-3, SOT-223 and TO-220 packages, and 0.2A for the TO-39 package.

Note 2: Regulation is measured at constant junction temperature, using pulse testing with a low duty cycle. Changes in output voltage due to heating effects are covered under the specification for thermal regulation. Load regulation is measured on the output pin at a point $1/8$ " below the base of the TO-3 and TO-39 packages.

Note 3: Selected devices with tightened tolerance reference voltage available.

Note 4: Refer to RETS137H drawing for LM137H or RETS137K drawing for LM137K military specifications.

Schematic Diagram

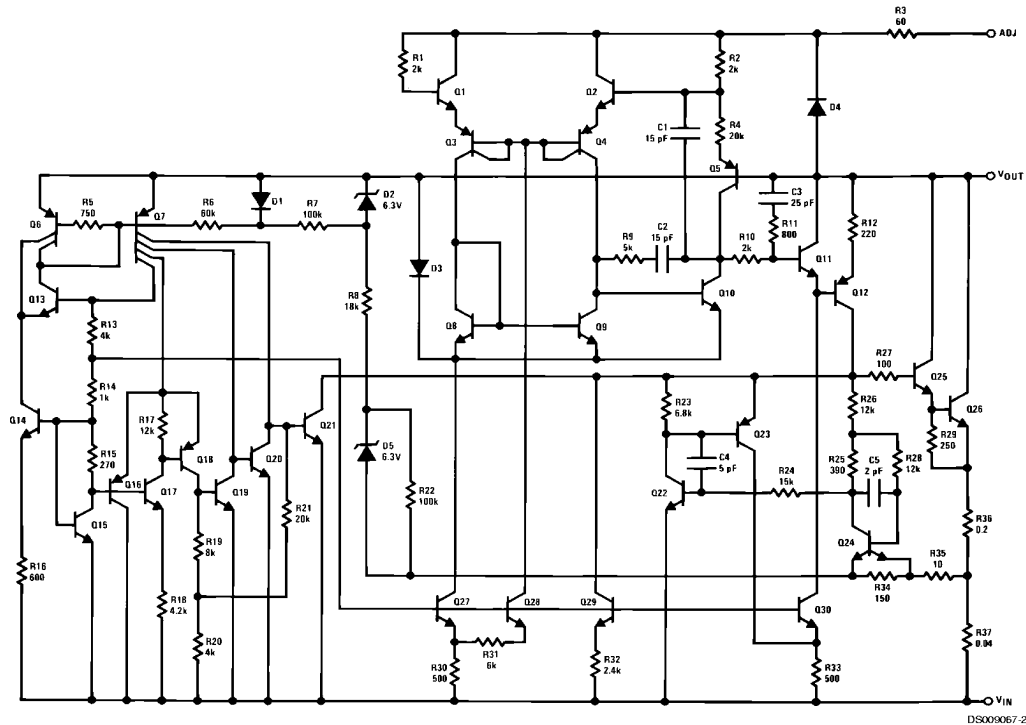

DS009067-2

Thermal Regulation

When power is dissipated in an IC, a temperature gradient occurs across the IC chip affecting the individual IC circuit components. With an IC regulator, this gradient can be especially severe since power dissipation is large. Thermal regulation is the effect of these temperature gradients on output voltage (in percentage output change) per Watt of power change in a specified time. Thermal regulation error is independent of electrical regulation or temperature coefficient, and occurs within 5 ms to 50 ms after a change in power dissipation. Thermal regulation depends on IC layout as well as electrical design. The thermal regulation of a voltage regulator is defined as the percentage change of V_{OUT} , per Watt, within the first 10 ms after a step of power is applied. The LM137's specification is 0.02%/W, max.

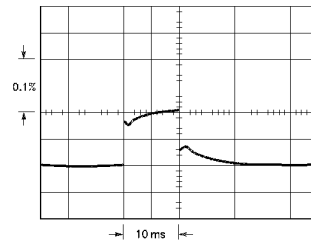

DS009067-3

LM137, $V_{OUT} = -10V$
 $V_{IN} - V_{OUT} = -40V$
 $I_{L} = 0A \rightarrow 0.25A \rightarrow 0A$
 Vertical sensitivity, 5 mV/div

FIGURE 1.

In Figure 1, a typical LM137's output drifts only 3 mV (or 0.03% of $V_{OUT} = -10V$) when a 10W pulse is applied for 10 ms. This performance is thus well inside the specification limit of $0.02\%/W \times 10W = 0.2\%$ max. When the 10W pulse is ended, the thermal regulation again shows a 3 mV step at the LM137 chip cools off. Note that the load regulation error of about 8 mV (0.08%) is additional to the thermal regulation error. In Figure 2, when the 10W pulse is applied for 100 ms,

Thermal Regulation (Continued)

the output drifts only slightly beyond the drift in the first 10 ms, and the thermal error stays well within 0.1% (10 mV).

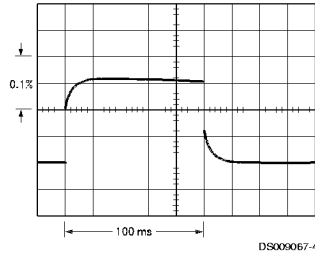

LM137, $V_{OUT} = -10V$
 $V_{IN} - V_{OUT} = -40V$
 $I_L = 0A \rightarrow 0.25A \rightarrow 0A$
 Horizontal sensitivity, 20 ms/div

FIGURE 2.

Connection Diagrams

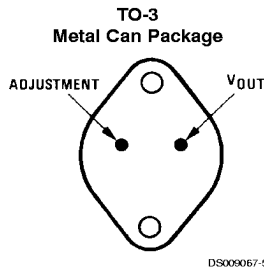

Case is Input

Bottom View
 Order Number LM137K/883
 See NS Package Number K02C
 Order Number LM337K STEEL
 See NS Package Number K02A

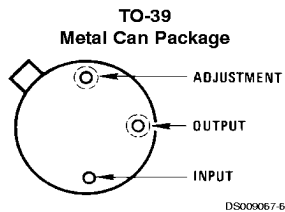

Case is Input

Bottom View
 Order Number LM137H, LM137H/883 or LM337H
 See NS Package Number H03A

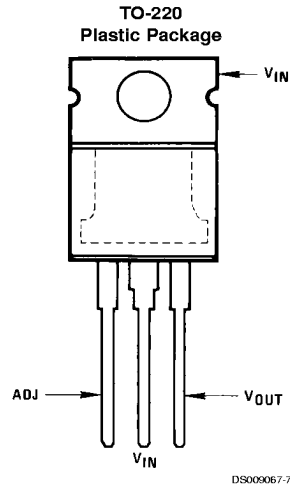

Front View
 Order Number LM337T
 See NS Package Number T03B

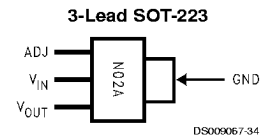

Front View
 Order Number LM337IMP
 Package Marked N02A See NS Package Number MA04A

Application Hints

When a value for $\theta_{(H-A)}$ is found using the equation shown, a heatsink must be selected that has a value that is less than or equal to this number.

HEATSINKING SOT-223 PACKAGE PARTS

The SOT-223 ("MP") packages use a copper plane on the PCB and the PCB itself as a heatsink. To optimize the heat sinking ability of the plane and PCB, solder the tab of the package to the plane.

Figures 3, 4 show the information for the SOT-223 package. Figure 4 assumes a $\theta_{(J-A)}$ of 75°C/W for 1 ounce copper and 51°C/W for 2 ounce copper and a maximum junction temperature of 125°C.

Application Hints (Continued)

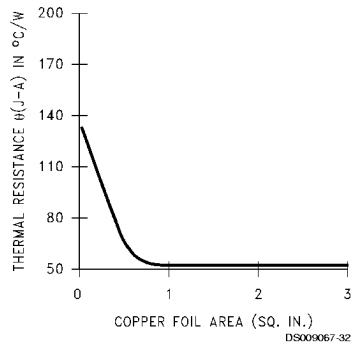

FIGURE 3. $\theta_{(J-A)}$ vs Copper (2 ounce) Area for the SOT-223 Package

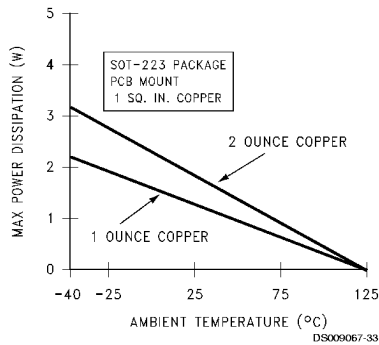
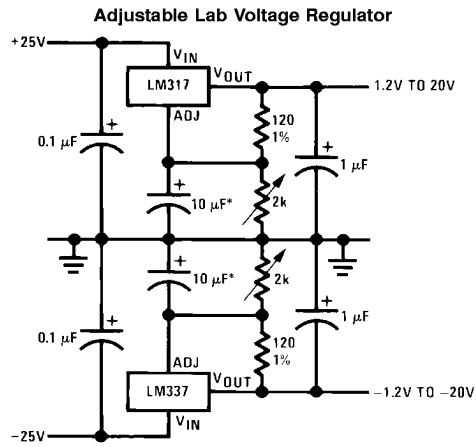

FIGURE 4. Maximum Power Dissipation vs T_{AMB} for the SOT-223 Package

Please see AN1028 for power enhancement techniques to be used with the SOT-223 package.

Typical Applications



Full output current not available at high input-output voltages
*The 10 μF capacitors are optional to improve ripple rejection

Current Regulator

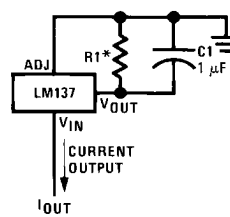

$$I_{OUT} = \frac{1.250V}{R1}$$

* $0.8\Omega \leq R1 \leq 120\Omega$

Negative Regulator with Protection Diodes

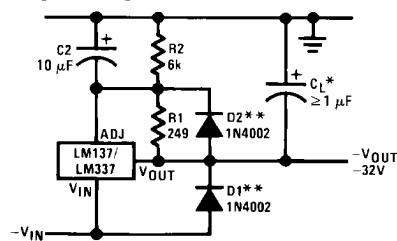

*When C_1 is larger than 20 μF , D1 protects the LM137 in case the input supply is shorted
**When C_2 is larger than 10 μF and $-V_{OUT}$ is larger than $-25V$, D2 protects the LM137 in case the output is shorted

Typical Applications (Continued)

-5.2V Regulator with Electronic Shutdown*

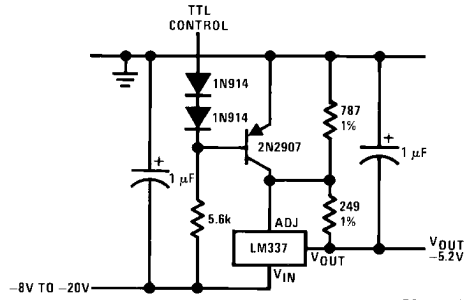

DS000067-10

*Minimum output $\cong -1.3V$ when control input is low

Adjustable Current Regulator

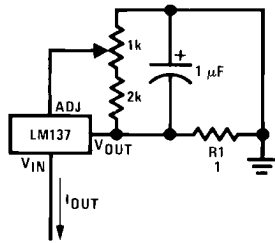

DS000067-12

$$I_{OUT} = \left(\frac{1.5V}{R1} \right) \pm 15\% \text{ adjustable}$$

High Stability -10V Regulator

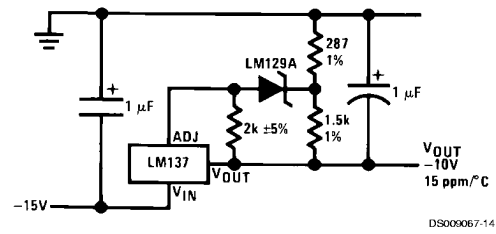

DS000067-14

Typical Performance Characteristics (K Steel and T Packages)

Load Regulation

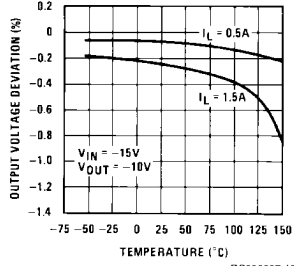

DS009067-16

Current Limit

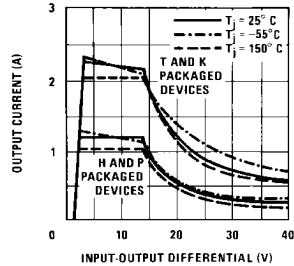

DS009067-17

Adjustment Current

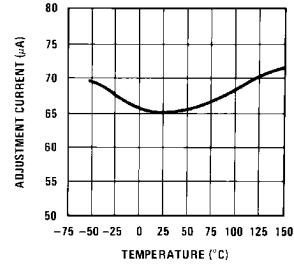

DS009067-18

Dropout Voltage

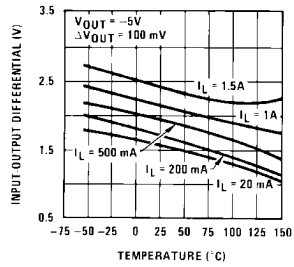

DS009067-19

Temperature Stability

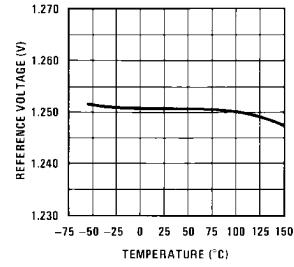

DS009067-20

Minimum Operating Current

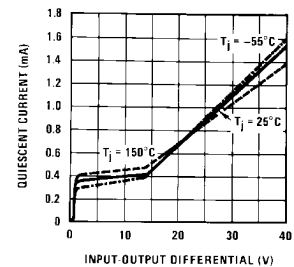

DS009067-21

Ripple Rejection

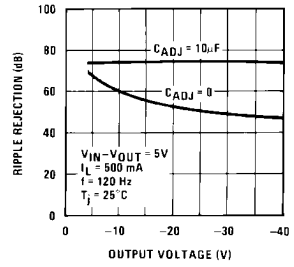

DS009067-22

Ripple Rejection

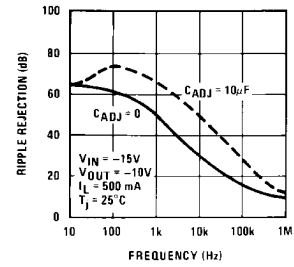

DS009067-23

Ripple Rejection

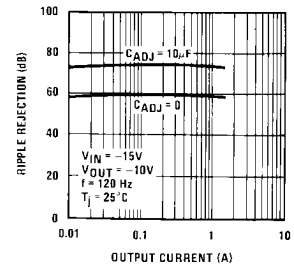

DS009067-24

Output Impedance

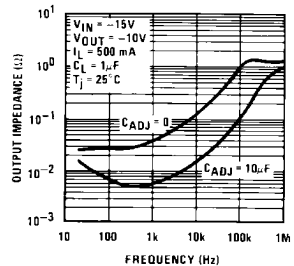

DS009067-25

Line Transient Response

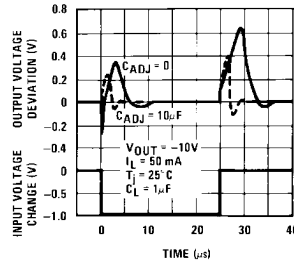

DS009067-26

Load Transient Response

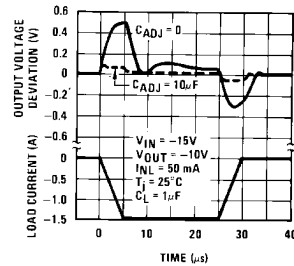

DS009067-27

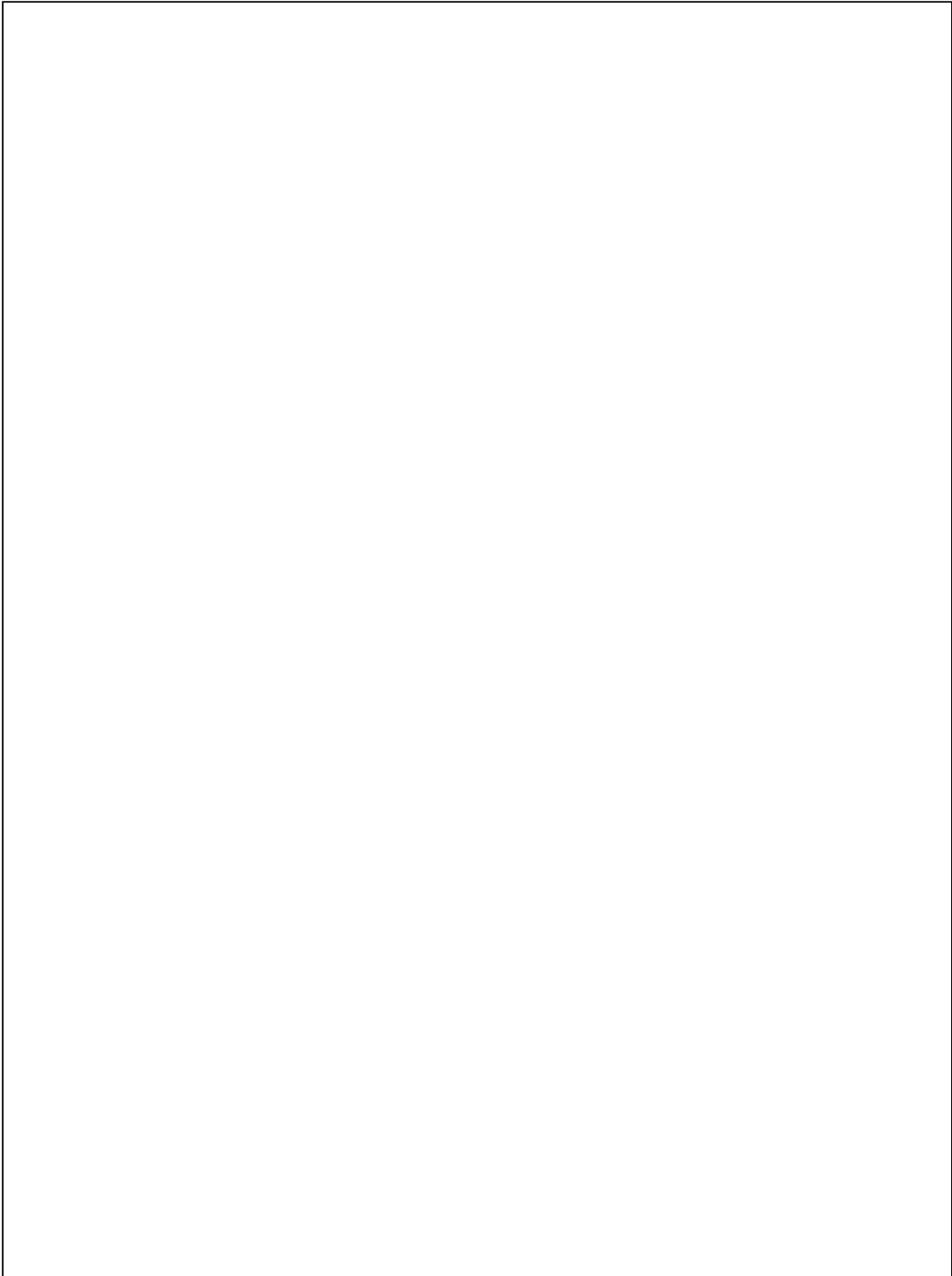

Physical Dimensions inches (millimeters) unless otherwise noted

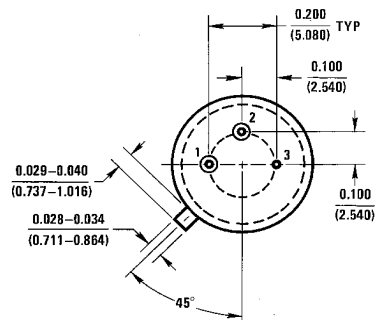
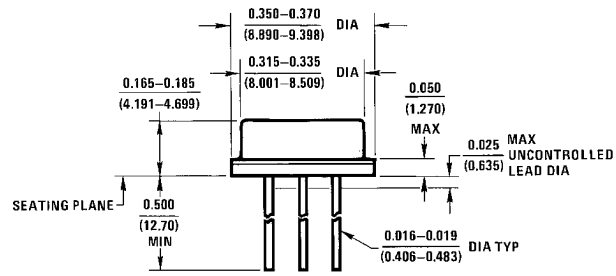

H03A (REV B)

Metal Can Package (H)
Order Number LM137H, LM137H/883 or LM337H
NS Package Number H03A

Physical Dimensions inches (millimeters) unless otherwise noted (Continued)

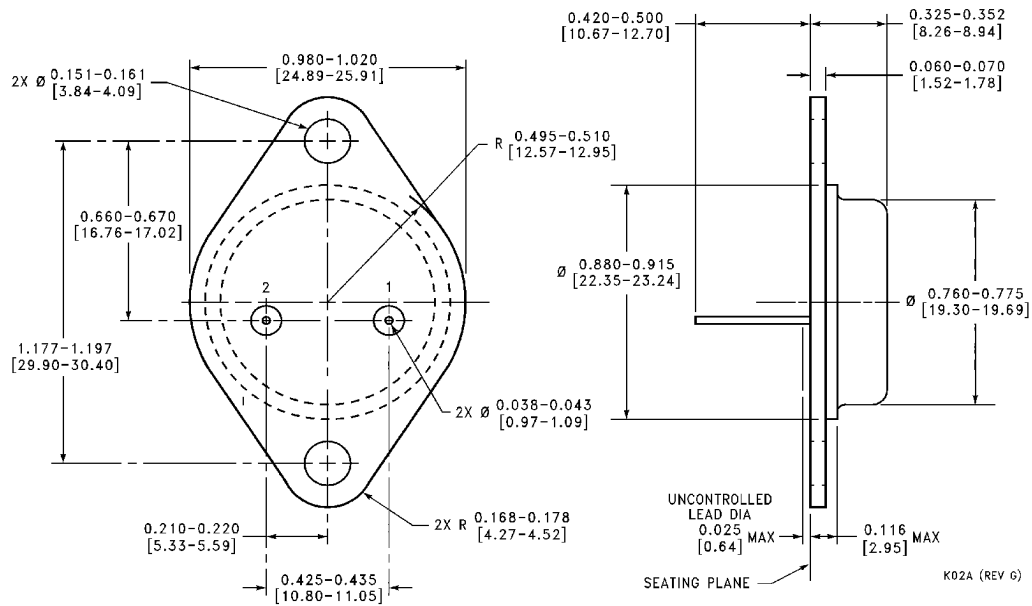

Metal Can Package (K)
Order Number LM337K STEEL
NS Package Number K02A

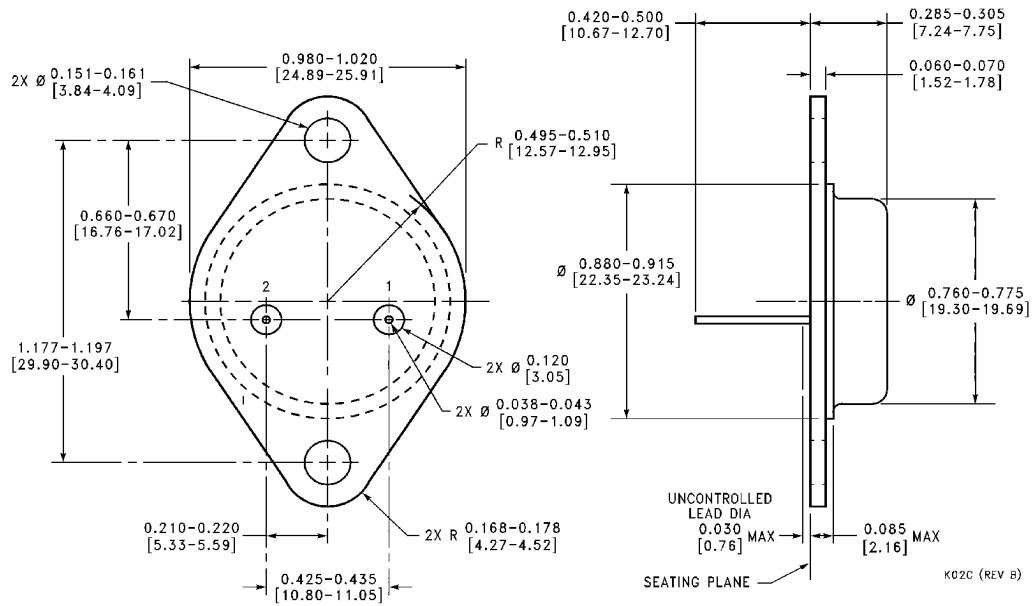

Mil-Aero Metal Can Package (K)
Order Number LM137K/883
NS Package Number K02C

Physical Dimensions inches (millimeters) unless otherwise noted (Continued)

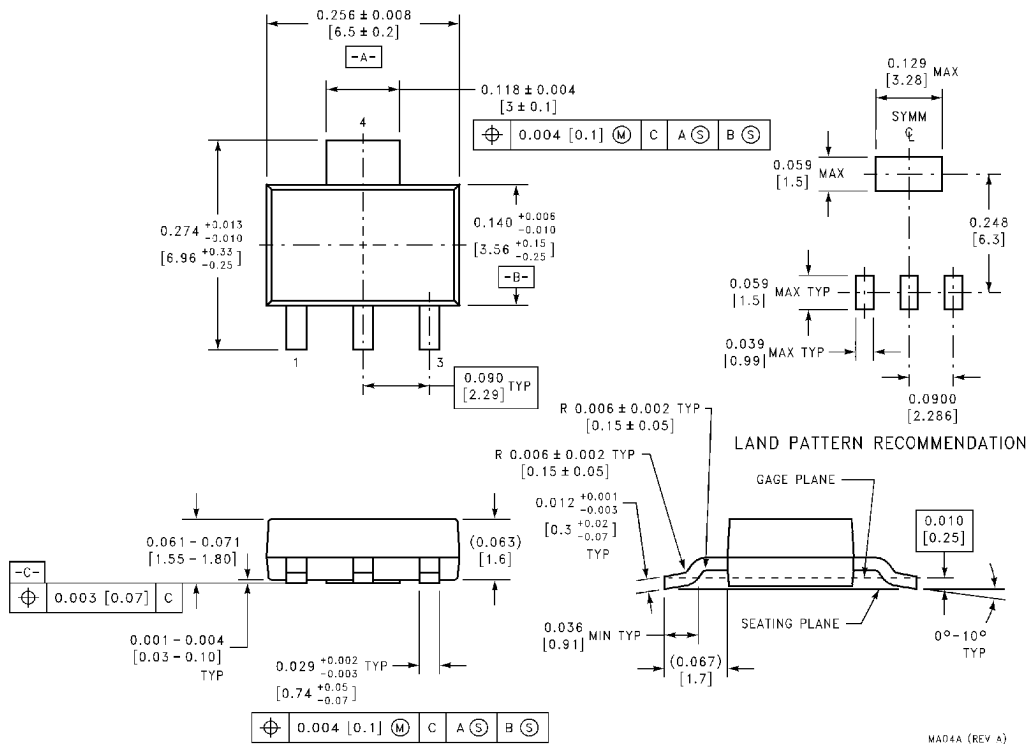

M04A (REV A)

**3-Lead SOT-223 Package
 Order Number LM337IMP
 NS Package Number M04A**

Physical Dimensions inches (millimeters) unless otherwise noted (Continued)

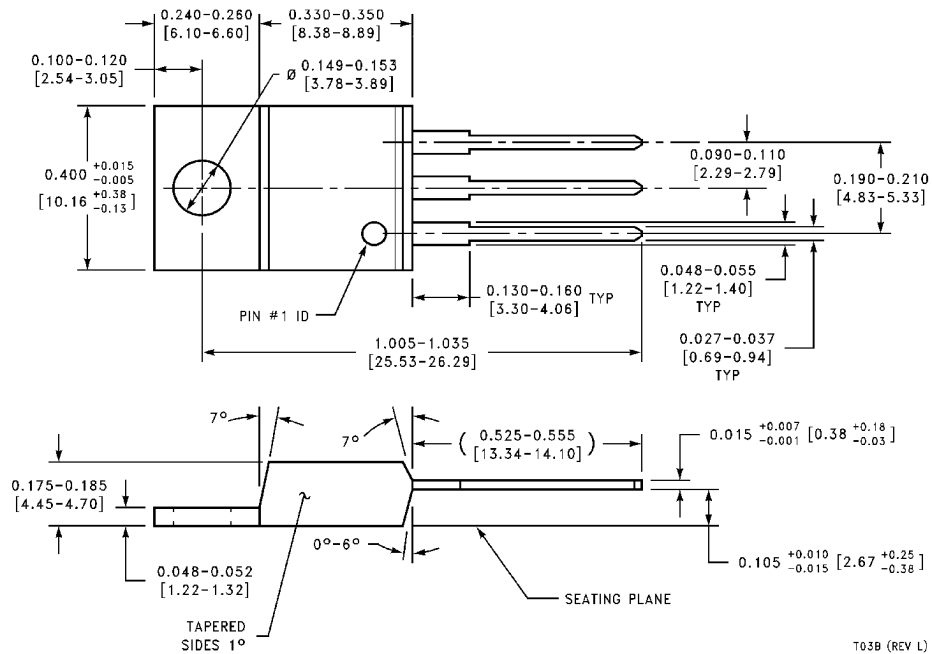

TO-220 Plastic Package (T)
Order Number LM337T
NS Package Number T03B

T03B (REV L)

LIFE SUPPORT POLICY

NATIONAL'S PRODUCTS ARE NOT AUTHORIZED FOR USE AS CRITICAL COMPONENTS IN LIFE SUPPORT DEVICES OR SYSTEMS WITHOUT THE EXPRESS WRITTEN APPROVAL OF THE PRESIDENT OF NATIONAL SEMICONDUCTOR CORPORATION. As used herein:

1. Life support devices or systems are devices or systems which, (a) are intended for surgical implant into the body, or (b) support or sustain life, and whose failure to perform when properly used in accordance with instructions for use provided in the labeling, can be reasonably expected to result in a significant injury to the user.
2. A critical component in any component of a life support device or system whose failure to perform can be reasonably expected to cause the failure of the life support device or system, or to affect its safety or effectiveness.



National Semiconductor Corporation
 Americas
 Tel: 1-800-272-9959
 Fax: 1-800-737-7018
 Email: support@nsc.com

National Semiconductor Europe
 Fax: +49 (0) 1 80-530 85 86
 Email: europe.support@nsc.com
 Deutsch Tel: +49 (0) 1 80-530 85 85
 English Tel: +49 (0) 1 80-532 78 32
 Français Tel: +49 (0) 1 80-532 93 58
 Italiano Tel: +49 (0) 1 80-534 16 80

National Semiconductor Asia Pacific Customer Response Group
 Tel: 65-2544466
 Fax: 65-2504466
 Email: sea.support@nsc.com

National Semiconductor Japan Ltd.
 Tel: 81-3-5620-6175
 Fax: 81-3-5620-6179

www.national.com

National does not assume any responsibility for use of any circuitry described, no circuit patent licenses are implied and National reserves the right at any time without notice to change said circuitry and specifications.