



LB11880

Three-Phase Sensorless Motor Driver with Loading Motor Driver

Overview

The LB11880 is a sensorless motor driver that also includes a loading motor driver. It is ideal for drum motor drive in VCR products.

Functions and Features

- Soft switching drive
- No Hall sensors required
- No FG sensors required
- Built-in PG amplifier
- Built-in thermal shutdown circuit
- Current limiter circuit
- On-chip loading motor driver

Package Dimensions

unit: mm

3196A-DIP30SD

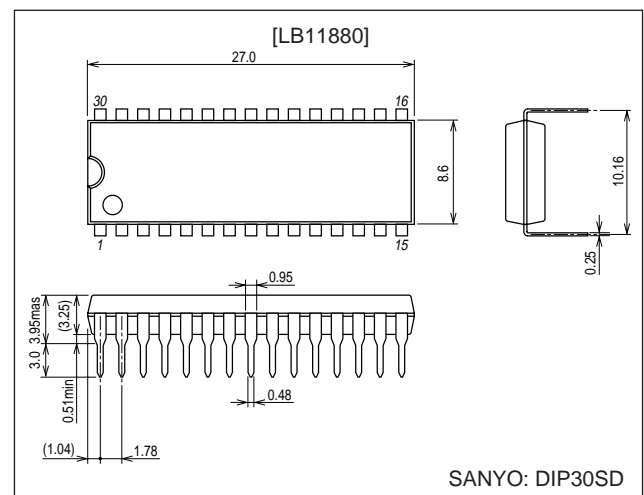

SANYO: DIP30SD

Specifications

Absolute Maximum Ratings at $T_a = 25^\circ\text{C}$

Parameter	Symbol	Conditions	Ratings	Unit
Maximum supply voltage 1	$V_{CC\ max}$		14.5	V
Maximum supply voltage 2	$V_{CCL\ max}$		14.5	V
Maximum supply voltage 3	$V_{REG\ max}$		7.0	V
Output voltage	V_{omax}		14.5	V
Input voltage	V_{I1max}		-0.3 to $V_{REG} + 0.3$	V
Cylinder current	I_{omax}		1.0	A
Loading current	$I_{omax\ (AVE)}$		0.4	A
	$I_{omax\ (peak)}$		1.2	A
Allowable power dissipation	P_{dmax}	When mounted on the specified printed circuit board*	2.8	W
Operating temperature	T_{opr}		-20 to +75	$^\circ\text{C}$
Storage temperature	T_{stg}		-55 to +150	$^\circ\text{C}$

Note: * Specified printed circuit board: 114.3 × 76.1 × 1.6 mm glass-epoxy board

■ Any and all SANYO products described or contained herein do not have specifications that can handle applications that require extremely high levels of reliability, such as life-support systems, aircraft's control systems, or other applications whose failure can be reasonably expected to result in serious physical and/or material damage. Consult with your SANYO representative nearest you before using any SANYO products described or contained herein in such applications.

■ SANYO assumes no responsibility for equipment failures that result from using products at values that exceed, even momentarily, rated values (such as maximum ratings, operating condition ranges, or other parameters) listed in products specifications of any and all SANYO products described or contained herein.

SANYO Electric Co., Ltd. Semiconductor Company

TOKYO OFFICE Tokyo Bldg., 1-10, 1 Chome, Ueno, Taito-ku, TOKYO, 110-8534 JAPAN

LB11880

Allowable Operating Ranges at $T_a = 25^\circ\text{C}$

Parameter	Symbol	Conditions	Ratings	Unit
Supply voltage 1	V_{CC}		8 to 13.8	V
Supply voltage 2	V_{CCL}		8 to 13.8	V
Supply voltage 3	VREG		4 to 6	V

Electrical Characteristics at $T_a = 25^\circ\text{C}$, $V_{CC} = V_{CCL} = 12\text{ V}$, $V_{REG} = 5\text{ V}$

Parameter	Symbol	Conditions	Ratings			Unit
			min	typ	max	
Supply current 1	I_{CC}	$V_C = 0\text{ V}$, $XIN = YIN = 0\text{ V}$		3.5	5.0	mA
Supply current 2	I_{CCL}	$V_C = 0\text{ V}$, $XIN = YIN = 0\text{ V}$			1	mA
Supply current 3	I_{REG}	$V_C = 0\text{ V}$, $XIN = YIN = 0\text{ V}$		10	15	mA
Output saturation voltage 1	V_{Osat1}	$IO = 0.4\text{ A}$, source + sink		1.4	2.0	V
Output saturation voltage 2	V_{Osat2}	$IO = 0.8\text{ A}$, source + sink		1.8	2.6	V
MC pin common-mode input voltage range	V_{IC}		0		$V_{CC} - 2$	V
VC pin input bias current	I_{VC}	$V_C = 0\text{ V}$	-2	-1		μA
Control start voltage	VTHVC	$V_{RF} = 10\text{ mA}$	2.4	2.5	2.6	V
Closed-loop control gain	GMVC	$R_F = 0.5\ \Omega$	0.75	0.95	1.15	A/V
PCOUT output current 1	I_{PCOU}	Source side		-90		μA
PCOUT output current 2	I_{PCOD}	Sink side		90		μA
VCOIN input current	I_{VCOIN}	$V_{COIN} = 5\text{ V}$		0.1	0.2	μA
Minimum VCO frequency	$f_{VCO\text{MIN}}$	$CX = 0.022\ \mu\text{F}$, $V_{COIN} = \text{open}$		400		Hz
Maximum VCO frequency	$f_{VCO\text{MAX}}$	$CX = 0.022\ \mu\text{F}$, $V_{COIN} = 5\text{ V}$		18.5		kHz
C1/C2 source current ratio	R_{SOURCE}	$I_{C1\text{SOURCE}}/I_{C2\text{SOURCE}}$	-12		+12	%
C1/C2 sink current ratio	R_{SINK}	$I_{C1\text{SINK}}/I_{C2\text{SINK}}$	-12		+12	%
C1 source/sink current ratio	RC1	$I_{C1\text{SOURCE}}/I_{C1\text{SINK}}$	-35		+15	%
C2 source/sink current ratio	RC2	$I_{C2\text{SOURCE}}/I_{C2\text{SINK}}$	-35		+15	%
Thermal shutdown operating temperature	T-TSD	*	150	180	210	$^\circ\text{C}$
Thermal shutdown hysteresis	ΔT_{TSD}	*		15		$^\circ\text{C}$

Note: * These values are design guarantee values, and are not tested.

FG/PG Amplifier Block at $T_a = 25^\circ\text{C}$, $V_{CC} = V_{CCL} = 12\text{ V}$, $V_{REG} = 5\text{ V}$

Parameter	Symbol	Conditions	Ratings			Unit
			min	typ	max	
[Back EMF FG]						
Output on voltage	V_{OL}				0.4	V
Output off voltage	V_{OH}		4.5			V
[PG Amplifier]						
Input offset voltage	V_{IO}		-8		+8	mV
Input bias current	I_{BIN-}		-250			nA
Common-mode input voltage range	V_{ICOM}	*	1		3.5	V
Open-loop gain	GVPG	$f = 1\text{ kHz}$		55		dB
Output on voltage	V_{OL}				0.4	V
Output off voltage	V_{OH}		4.5			V
Schmitt amplifier hysteresis	V_{Shys}		70	93	115	mV

Note: * These values are design guarantee values, and are not tested.

LB11880

Loading Block at $T_a = 25^\circ\text{C}$, $V_{CC} = V_{CCL} = 12\text{ V}$, $V_{REG} = 5\text{ V}$

Parameter		Symbol	Conditions	Ratings			Unit
				min	typ	max	
Input voltage	1 (high)	V_{IN1}		3.5		5	V
	2 (low)	V_{IN2}		0		0.8	V
Input current		I_{IN}	Sink $V_{IN} = 3.5\text{ V}$		30	50	μA
Input hysteresis		ΔVT			0.7		V
Saturation voltage	$V_{sat\ U-1}$		$V_{ref} = VS$, between the output and VS $I_O = 0.2\text{ A}$, CW/CCW mode		1.5	2.1	V
	$V_{sat\ L-1}$		$V_{ref} = VS$, between the output and ground $I_O = 0.2\text{ A}$, CW/CCW mode		0.2	0.3	V
	$V_{sat\ U-1'}$		$V_{ref} = VS$, between the output and VS $I_O = 0.4\text{ A}$, CW/CCW mode		1.6	2.2	V
	$V_{sat\ L-1'}$		$V_{ref} = VS$, between the output and ground $I_O = 0.4\text{ A}$, CW/CCW mode		0.3	0.5	V
Upper side residual voltage	$V_{satU-1''}$		$V_{ref} = 8\text{ V}$, between the output and ground $I_O = 0.2\text{ A}$, CW/CCW mode	7.2	8.0	8.8	V
	$V_{satL-1''}$		$V_{ref} = 8\text{ V}$, between the output and ground $I_O = 0.4\text{ A}$, CW/CCW mode	7.2	8.0	8.8	V
Output transistor leakage current	Upper	ILU				50	μA
	Lower	ILL				50	μA
Diode forward voltage	Uper	VFU	$I_F = 0.4\text{ A}$		1.3		V
	Lower	VFL	$I_F = 0.4\text{ A}$		1.0		V
Control supply current		I_{ref}		-5	-2		μA

LB11880

Loading Motor Truth Table

Input		Output		Mode
X _{IN}	Y _{IN}	X _{OUT}	Y _{OUT}	
L	L	Off	Off	Standby
H	L	H	L	Forward
L	H	L	H	Reverse
H	H	L	L	Brake

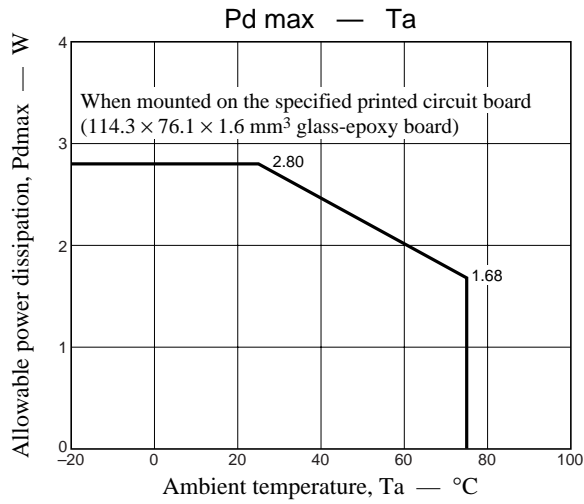

Pin Assignment

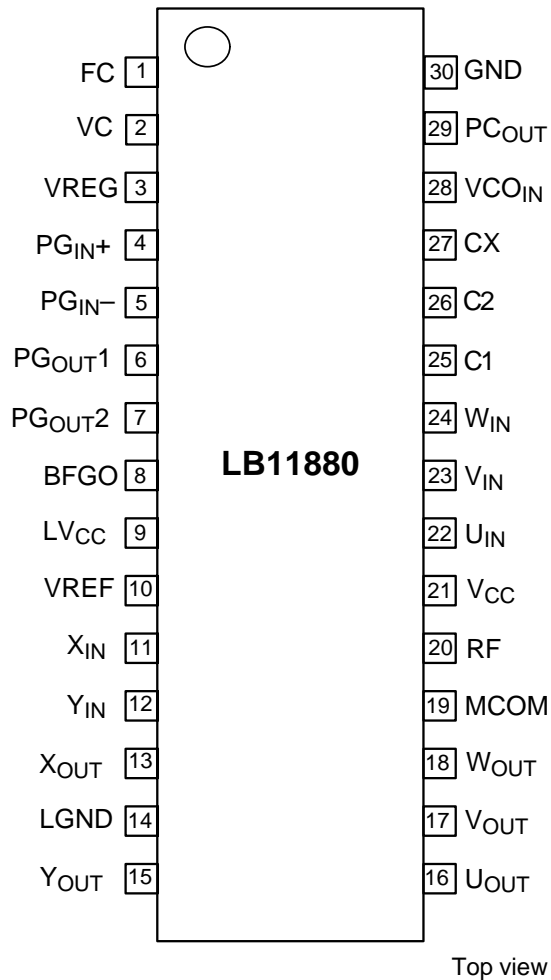

Block Diagram (Note that the values of the external components depend on the motor used.)

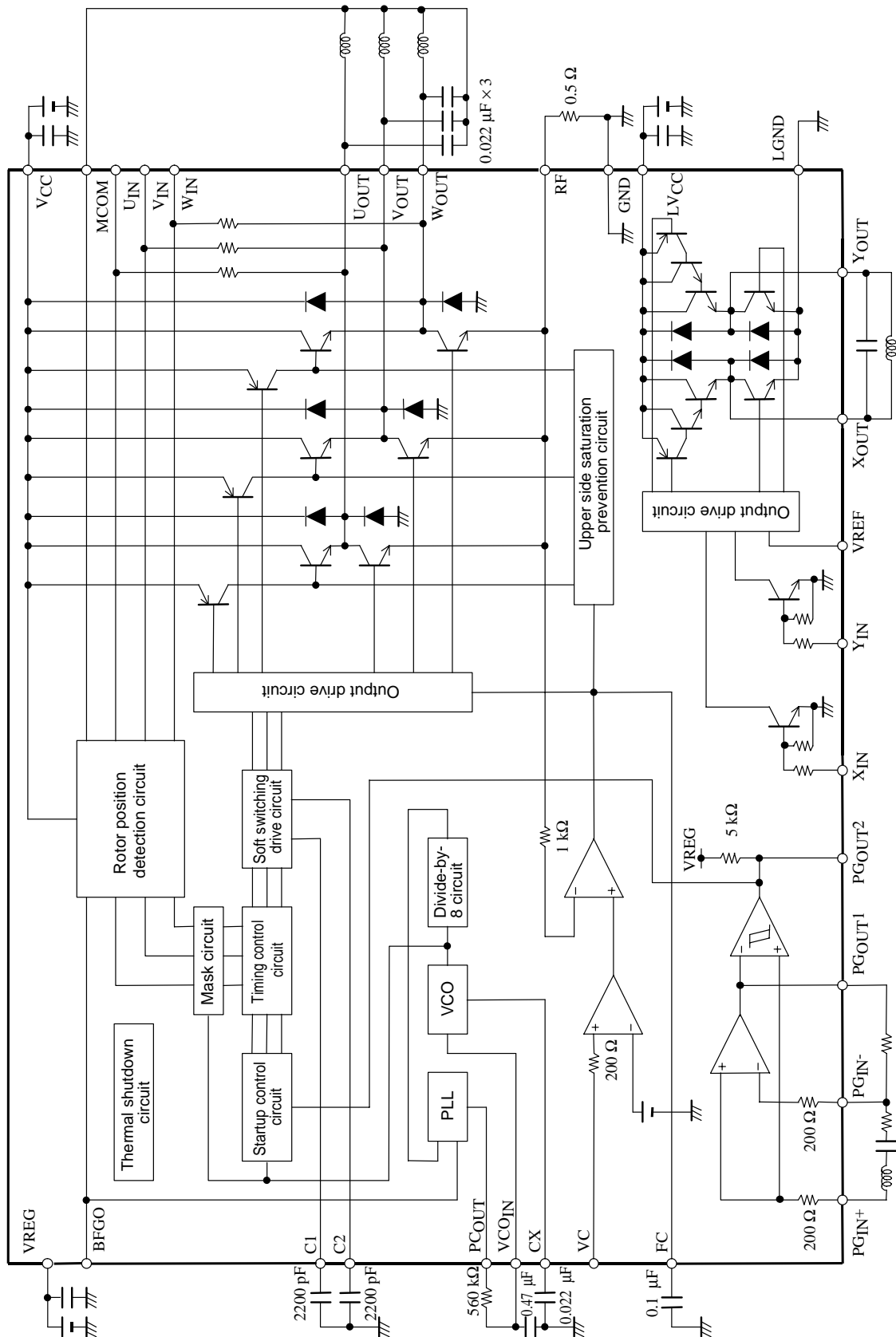

Pin Description

Pin No.	Pin	Pin voltage	Function	Equivalent circuit
1	FC		<p>Frequency characteristics compensation</p> <p>Oscillation in the current control system closed loop can be prevented by connecting a capacitor between this pin and ground.</p>	
2	VC	0 V to VREG	<p>Speed control</p> <p>This circuit implements constant-current control in which current feedback is applied from the RF system.</p>	
3	VREG	4 V to 6 V	<p>Control system power supply</p> <p>This power supply must be stabilized so that ripple and noise do not enter the IC.</p>	
4	PG _{IN+}		<p>PG amplifier plus side input</p> <p>This pin is biased to 1/2 VREG internally.</p>	
5	PG _{IN-}		<p>PG amplifier minus side input</p>	
6	PG _{OUT1}		<p>PG amplifier linear output</p>	

Continued on next page.

LB11880

Continued from preceding page.

Pin No.	Pin	Pin voltage	Function	Equivalent circuit
7	PG _{OUT2}		PG Schmitt amplifier output	
8	BFGO		Motor back EMF voltage detection FG output (synthesized from three phases)	
9	LV _{CC}	8 to 13.8 V	Loading motor driver output transistor power supply	
10	VREF	0 to V _{CC} L	Loading motor driver output voltage setting	
11	X _{IN}	0 V to VREG	Loading motor driver logic input	
12	Y _{IN}			
13	X _{OUT}		Loading motor driver output	
15	Y _{OUT}			
14	LGND		Loading motor driver output transistor ground	

Continued on next page.

Continued from preceding page.

Pin No.	Pin	Pin voltage	Function	Equivalent circuit
16	U _{OUT}		Drum motor driver output	
17	V _{OUT}			
18	W _{OUT}			
20	RF	8 to 13.8 V	<p>Lowest potential of the drum motor driver output transistor</p> <p>This IC implements constant-current control by detecting this voltage.</p> <p>The current limiter also operates by detecting this voltage.</p>	
21	V _{CC}	8 to 13.8 V	Internal reference voltage and power supply for both the drum motor driver output block and the coil waveform detection circuit.	
19	MCOM		Motor coil center input	
22	U _{IN}		Coil waveform detection comparator input	
23	V _{IN}		Each phase output is connected by an internal 10 kΩ resistor.	
24	W _{IN}			
25	C1		Triangular wave generating capacitor connection	
26	C2		This triangular wave is used to implement soft switching in the coil output waveform.	
27	CX		The value of the capacitor connected between this pin and ground determines the operating frequency range and the minimum operating frequency of the VCO circuit.	

Continued on next page.

Continued from preceding page.

Pin No.	Pin	Pin voltage	Function	Equivalent circuit
28	VCO _{IN}		VCO circuit voltage input The PCOUT pin voltage is filtered by an RC circuit and input to this pin.	
29	PC _{OUT}		VCO circuit PLL output	
30	GND		Ground for all circuits other than the drum and loading driver output transistors.	

- Specifications of any and all SANYO products described or contained herein stipulate the performance, characteristics, and functions of the described products in the independent state, and are not guarantees of the performance, characteristics, and functions of the described products as mounted in the customer's products or equipment. To verify symptoms and states that cannot be evaluated in an independent device, the customer should always evaluate and test devices mounted in the customer's products or equipment.
- SANYO Electric Co., Ltd. strives to supply high-quality high-reliability products. However, any and all semiconductor products fail with some probability. It is possible that these probabilistic failures could give rise to accidents or events that could endanger human lives, that could give rise to smoke or fire, or that could cause damage to other property. When designing equipment, adopt safety measures so that these kinds of accidents or events cannot occur. Such measures include but are not limited to protective circuits and error prevention circuits for safe design, redundant design, and structural design.
- In the event that any or all SANYO products (including technical data, services) described or contained herein are controlled under any of applicable local export control laws and regulations, such products must not be exported without obtaining the export license from the authorities concerned in accordance with the above law.
- No part of this publication may be reproduced or transmitted in any form or by any means, electronic or mechanical, including photocopying and recording, or any information storage or retrieval system, or otherwise, without the prior written permission of SANYO Electric Co., Ltd.
- Any and all information described or contained herein are subject to change without notice due to product/technology improvement, etc. When designing equipment, refer to the "Delivery Specification" for the SANYO product that you intend to use.
- Information (including circuit diagrams and circuit parameters) herein is for example only; it is not guaranteed for volume production. SANYO believes information herein is accurate and reliable, but no guarantees are made or implied regarding its use or any infringements of intellectual property rights or other rights of third parties.

This catalog provides information as of May, 2000. Specifications and information herein are subject to change without notice.