

**LA7806****B/W TV Synchronization, Deflection Circuit****Overview**

The LA7806 is a multifunctional integrated circuit which is based on the internal circuit of the LA7800, incorporates various functions required for synchronization and deflection circuits of monochromatic television set, and operates on line voltage or from battery. This IC was so designed as to streamline the set by making the device more compact (DIP-16) and reducing the number of parts.

The LA7806 differs from the LA7800 in the following points.

- No X-ray protection circuit is used.
- The ground pins for horizontal and vertical are provided separately.
- No horizontal regulator is used.
- Synchronizing separation output is for vertical only.

Functions

- Synchro separator.
- Horizontal AFC.
- Vertical driver.
- Horizontal oscillator.
- Vertical oscillator.
- Vertical blanking pulse making.

Features

- Multifunction and small-size (DIP-16).
- Minimum number of parts required.
- Horizontal and vertical oscillators being stable to variation of ambient temperature and supply voltage owing to small warming-up drift.
- Small variation of horizontal oscillation frequency.
- Good linearity and interlace owing to DC bias at vertical output stage being sampling controlled within retrace time.
- Vertical blanking pulse width being freely set up according to peripheral parts.

Package Dimensions

unit:mm

3006B-DIP16

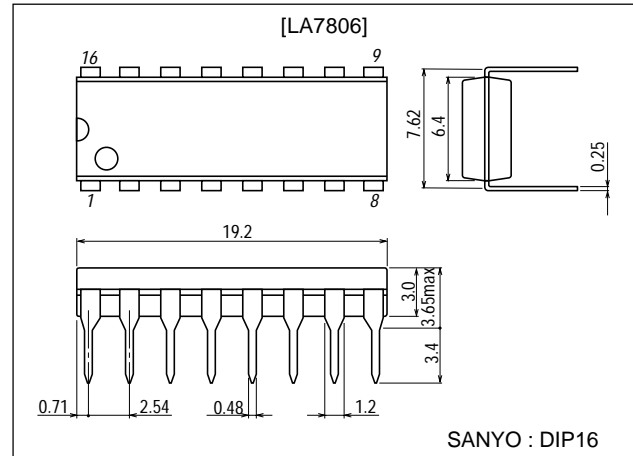

■ Any and all SANYO products described or contained herein do not have specifications that can handle applications that require extremely high levels of reliability, such as life-support systems, aircraft's control systems, or other applications whose failure can be reasonably expected to result in serious physical and/or material damage. Consult with your SANYO representative nearest you before using any SANYO products described or contained herein in such applications.

■ SANYO assumes no responsibility for equipment failures that result from using products at values that exceed, even momentarily, rated values (such as maximum ratings, operating condition ranges, or other parameters) listed in products specifications of any and all SANYO products described or contained herein.

SANYO Electric Co.,Ltd. Semiconductor Company

TOKYO OFFICE Tokyo Bldg., 1-10, 1 Chome, Ueno, Taito-ku, TOKYO, 110-8534 JAPAN

LA7806

Specifications

Maximum Ratings at $T_a = 25^\circ\text{C}$

Parameter	Symbol	Conditions	Ratings	Unit
Maximum supply voltage	V_{12}, V_{15}		14	V
Allowable power dissipation	$P_d \text{ max}$	$T_a=60^\circ\text{C}$	450	mW
Operating temperature	T_{opr}		-20 to +85	$^\circ\text{C}$
Storage temperature	T_{stg}		-55 to +125	$^\circ\text{C}$

Recommended Operating Conditions at $T_a = 25^\circ\text{C}$

Parameter	Symbol	Conditions	Ratings	Unit
Recommended supply voltage	V_{12}, V_{15}		12	V

Operating Characteristics at $T_a = 25^\circ\text{C}, V_{12}=V_{15}=12\text{V}$

Parameter	Symbol	Conditions	Ratings			Unit
			min	typ	max	
V_{CC12} current drain	I_{CC12}		10.0		19.0	mA
V_{CC15} current drain	I_{CC15}		6.0		11.0	mA
Vertical frequency pull-in range			9.0		11.0	Hz
Vertical free-running frequency	f_V	f_V center 55Hz	50		60	Hz
Supply voltage dependence of vertical frequency		$V_{12}=12\pm 1\text{V}, 55\text{Hz}$ at 12V	-0.5		+0.5	Hz
Temperature characteristic of vertical frequency		$T_a=-10$ to $+60^\circ\text{C}$	-0.028		+0.028	Hz/ $^\circ\text{C}$
Vertical driver amplification factor			4.0		7.0	times
Horizontal free-running frequency	f_H	f_H center 15.750kHz	-750		+750	Hz
Supply voltage dependence of horizontal frequency		$V_{15}=12\pm 1\text{V}, 15.750\text{kHz}$ at 12V	-50		+50	Hz
Temperature characteristic of horizontal frequency		$T_a=-10$ to $+60^\circ\text{C}$	-3.4		+3.4	Hz/ $^\circ\text{C}$
Horizontal output pulse width		$f_H=15.750\text{kHz}$	21.5		26.5	μs
Horizontal output drive current			4.2		7.8	mA

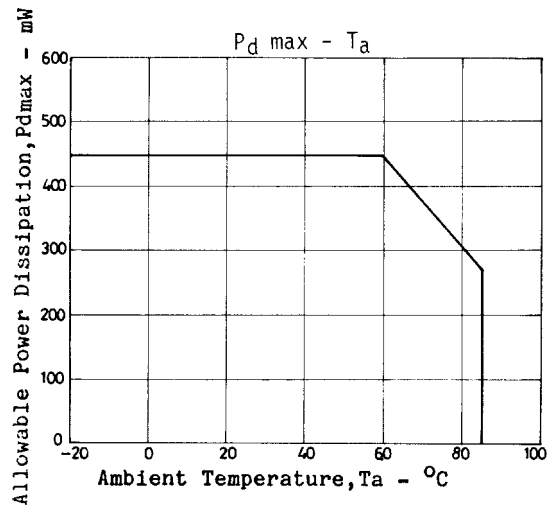

Sample Application Circuit

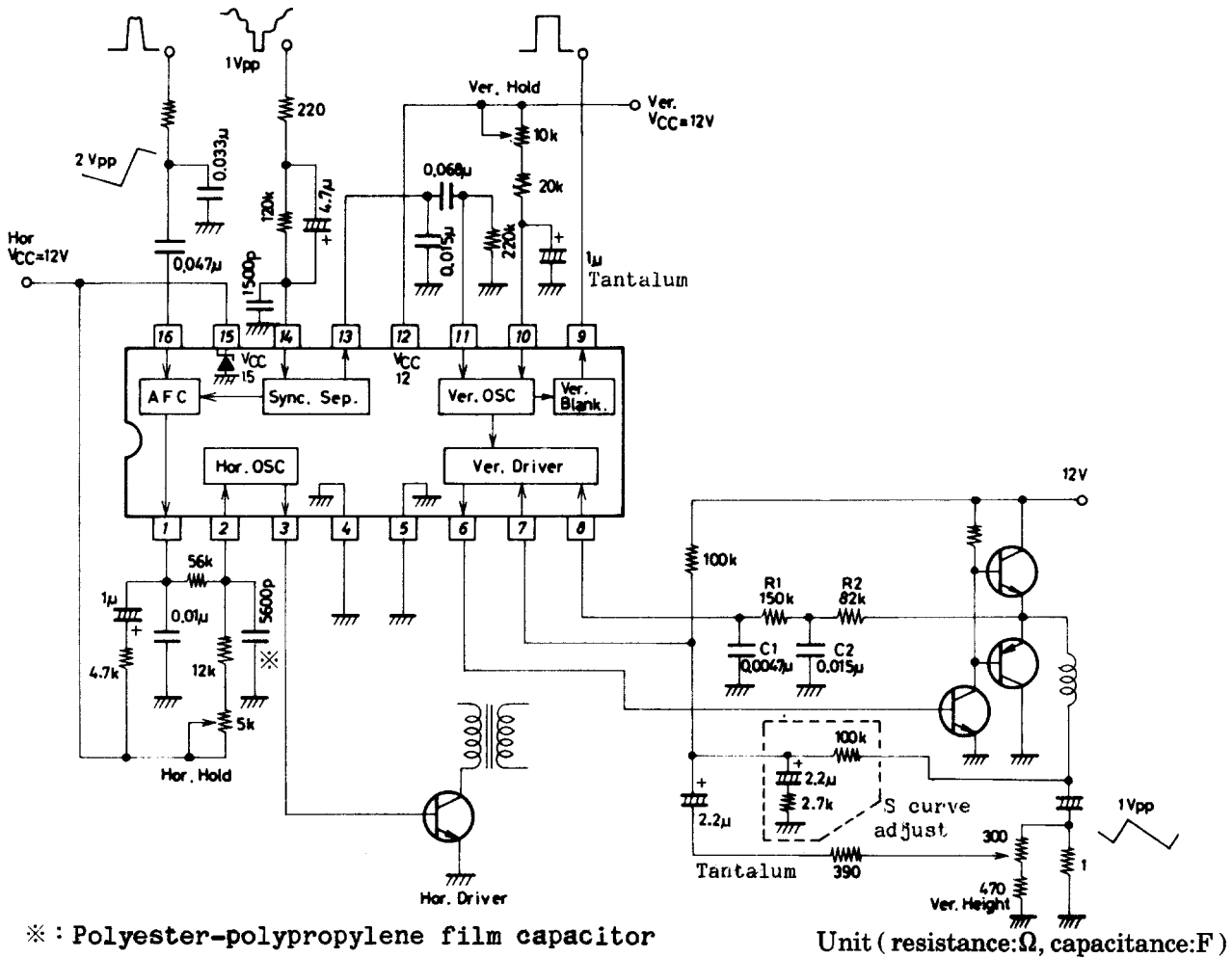

- Note) 1. The vertical output circuit is shown by the basic circuit.
 2. The peripheral parts at pin 8 should be changed in accordance with the Ver. Out circuit conditions.
 3. The limiting resistor (220Ω : 1Vp-p) at pin 14 should be changed in proportion to the magnitude of the input video signal.
 4. In the time constant circuit (120kΩ, 4.7μF) at pin 14, the time constant should be changed by changing the resistance value in accordance with the DC level of the input video signal and then by changing the capacitance value.

Peripheral parts at pin 8 (other applications)

	R1	C1	R2	C2
Line operate	220kΩ	0.01μF	68kΩ	0.068μF
Battery drive (pump-up)	220kΩ	0.0033μF	82kΩ	0.068μF

- Specifications of any and all SANYO products described or contained herein stipulate the performance, characteristics, and functions of the described products in the independent state, and are not guarantees of the performance, characteristics, and functions of the described products as mounted in the customer's products or equipment. To verify symptoms and states that cannot be evaluated in an independent device, the customer should always evaluate and test devices mounted in the customer's products or equipment.
- SANYO Electric Co., Ltd. strives to supply high-quality high-reliability products. However, any and all semiconductor products fail with some probability. It is possible that these probabilistic failures could give rise to accidents or events that could endanger human lives, that could give rise to smoke or fire, or that could cause damage to other property. When designing equipment, adopt safety measures so that these kinds of accidents or events cannot occur. Such measures include but are not limited to protective circuits and error prevention circuits for safe design, redundant design, and structural design.
- In the event that any or all SANYO products(including technical data, services) described or contained herein are controlled under any of applicable local export control laws and regulations, such products must not be exported without obtaining the export license from the authorities concerned in accordance with the above law.
- No part of this publication may be reproduced or transmitted in any form or by any means, electronic or mechanical, including photocopying and recording, or any information storage or retrieval system, or otherwise, without the prior written permission of SANYO Electric Co., Ltd.
- Any and all information described or contained herein are subject to change without notice due to product/technology improvement, etc. When designing equipment, refer to the "Delivery Specification" for the SANYO product that you intend to use.
- Information (including circuit diagrams and circuit parameters) herein is for example only ; it is not guaranteed for volume production. SANYO believes information herein is accurate and reliable, but no guarantees are made or implied regarding its use or any infringements of intellectual property rights or other rights of third parties.

This catalog provides information as of January, 2001. Specifications and information herein are subject to change without notice.