

5-BAND GRAPHIC EQUALIZER AMPLIFIER

The KA2223 is a monolithic integrated circuit consisting of an operational amplifier with five resonant circuits and a active filter, and it is suitable for radio-cassette tape recorders, car stereos or music center audio systems.

FEATURES

- Tone control with independent adjustment of each band through an external capacitor.
- Gain control through an external variable resistor.
- Increasing the bands by adding resonant circuit or using two KA2223 in series.
- Low noise ($V_{NO} = 7\mu V$; Typ. Flat).
- Low distortion (THD=0.02% Typ. $f = 1\text{KHz}$ Flat).
- Large allowable input ($V_i = 2.3\text{V}$; Typ, $V_{CC} = 9\text{V}$, $f = 1\text{KHz}$ Flat).
- Operating supply voltage range: $V_{CC} = 5\text{V} \sim 13\text{V}$

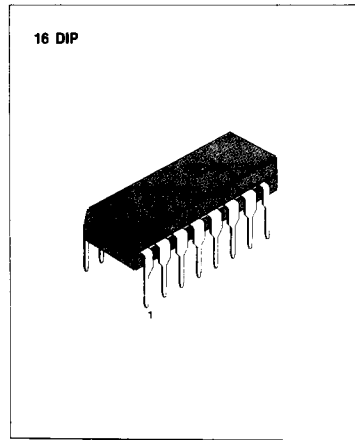

ORDERING INFORMATION

Device	Package	Operating Temperature
KA2223	16 DIP	-20°C ~ +70°C

BLOCK DIAGRAM

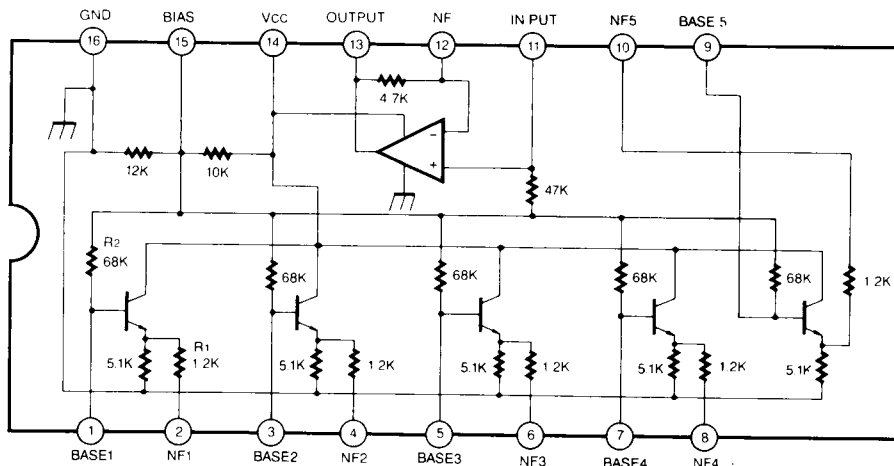

Fig. 1

ABSOLUTE MAXIMUM RATINGS (Ta = 25°C)

Characteristic	Symbol	Value	Unit
Supply Voltage	V _{CC}	20	V
Power Dissipation	P _D	700	mW
Operating Temperature	T _{OPR}	-20 ~ +70	°C
Storage Temperature	T _{STG}	-55 ~ +125	°C

ELECTRICAL CHARACTERISTICS

(Ta = 25°C, V_{CC} = 9V unless otherwise specified)

Characteristic	Symbol	Test		Min	Typ	Max	Unit	
		f(Hz)	Conditions					
Quiescent Circuit Current	I _{CCO}		V _I = 0	3.0	5.2	8.0	mA	
Voltage Gain	Flat	G _V (Flat)	1K	V _I = -10dBm	-3.8	-0.8	2.2	dB
	Boost	G _V (Boost)	343	V _I = -10dBm	-12	-10.5	-8	dB
			1.08K					
			3.43K					
			10.8K					
	Cut	G _V (Cut)	108	V _I = -10dBm	-12	-10.5	-8	dB
			343					
			1.08K					
			3.43K					
10.8K								
Total Harmonic Distortion	THD	1K	V _I = 1V		0.02	0.1	%	
Output Noise Voltage	V _{NO}	Flat, Input Short BW(-3dB) = 10Hz ~ 30KHz			7.0	30	μV	

TEST CIRCUIT

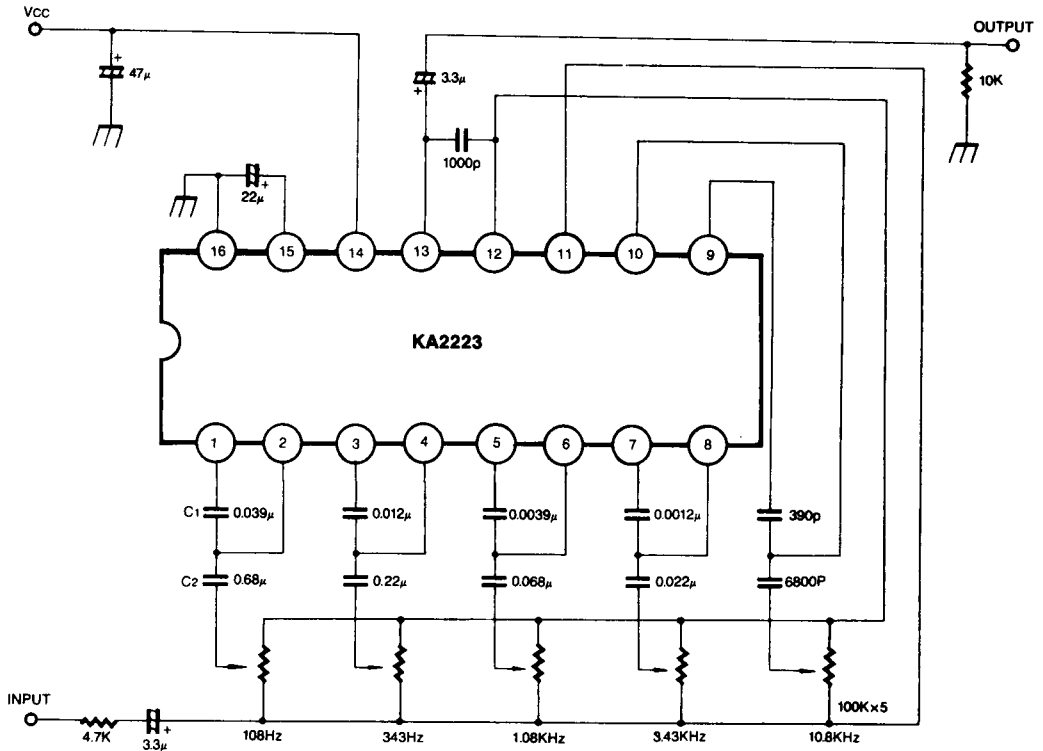

Fig. 2

$$\text{Resonant frequency } f_0 = \frac{1}{2\pi\sqrt{R_1 R_2 C_1 C_2}}$$

($R_1 = 1.2K$, $R_2 = 68K$ on-chip resistor)

APPLICATION CIRCUIT

1. 7 BAND

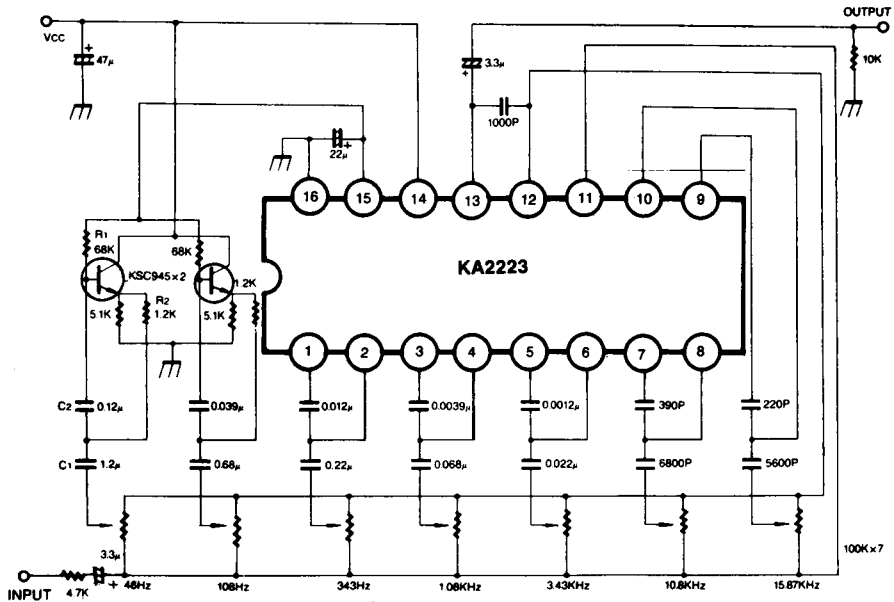

Fig. 3

2. 10 BAND

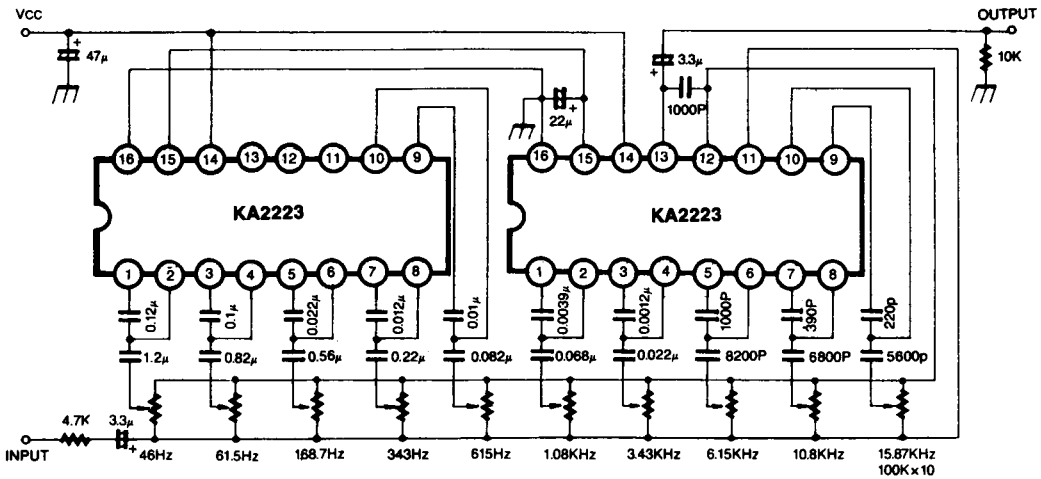

Fig. 4