



ISD2560/75/90/120 Products

Single-Chip Voice Record/Playback Devices

60-, 75-, 90-, and 120-Second Durations

GENERAL DESCRIPTION

Information Storage Devices' ISD2500 ChipCorder® Series provides high-quality, single-chip record/playback solutions for 60- to 120-second messaging applications. The CMOS devices include an on-chip oscillator, microphone preamplifier, automatic gain control, antialiasing filter, smoothing filter, speaker amplifier, and high density multilevel storage array. In addition, the ISD2500 is microcontroller compatible, allowing complex messaging and addressing to be achieved.

Recordings are stored in on-chip nonvolatile memory cells, providing zero-power message storage. This unique, single-chip solution is made possible through ISD's patented multilevel storage technology. Voice and audio signals are stored directly into memory in their natural form, providing high-quality, solid-state voice reproduction.

Figure: ISD2560/75/90/120 Device Block Diagram

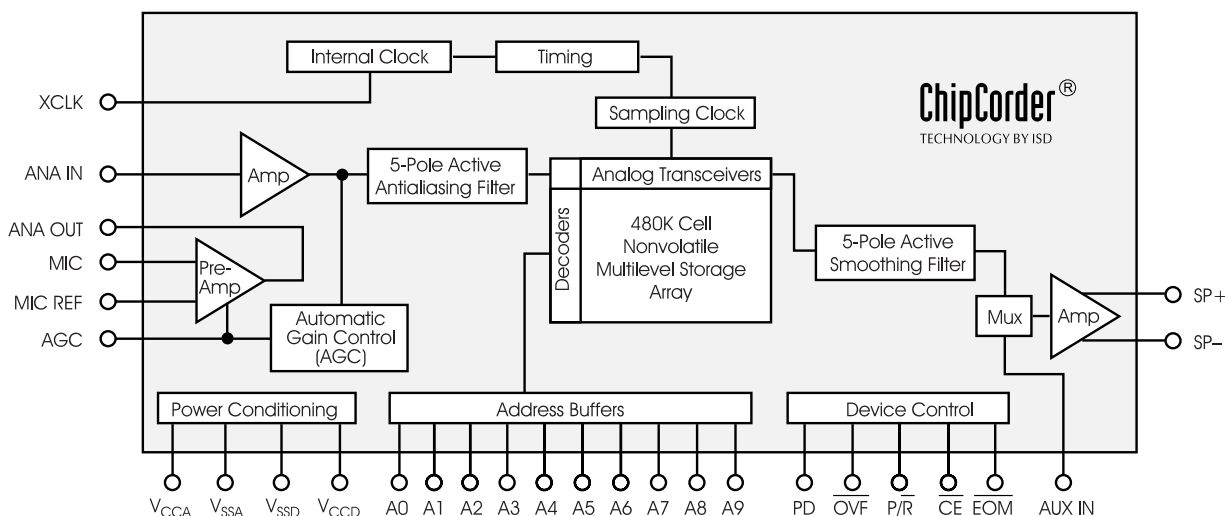

FEATURES

- Easy-to-use single-chip voice record/playback solution
 - High-quality, natural voice/audio reproduction
 - Manual switch or microcontroller compatible playback can be edge- or level-activated
 - Single-chip durations of 60, 75, 90, and 120 seconds
 - Directly cascadable for longer durations
 - Automatic Power-Down (Push-Button Mode)
 - Standby current 1 μ A (typical)
 - Zero-power message storage
 - Eliminates battery backup circuits
 - Fully addressable to handle multiple messages
 - 100-year message retention (typical)
 - 100,000 record cycles (typical)
 - On-chip clock source
 - Programmer support for play-only applications
 - Single +5 volt power supply
 - Available in die form, DIP, and TSOP packaging
 - Industrial temperature (-40°C to +85°C) versions available
-

Table: ISD2560/75/90/120 Product Summary

Part Number	Duration (Seconds)	Input Sample Rate (KHz)	Typical Filter Pass Band (KHz)
ISD2560	60	8.0	3.4
ISD2575	75	6.4	2.7
ISD2590	90	5.3	2.3
ISD25120	120	4.0	1.7

Table of Contents

ISD2560/75/90/120 Products

Single-Chip Voice Record/Playback Devices
60-, 75-, 90-, and 120-Second Durations

DETAILED DESCRIPTION	1
Speech/Sound Quality	1
Duration	1
EEPROM Storage	1
Microcontroller Interface	1
Programming	1
PIN DESCRIPTIONS	2
Voltage Inputs (V_{CCA} , V_{CCD})	2
Ground Inputs (V_{SSA} , V_{SSD})	2
Power Down Input (PD)	2
Chip Enable Input (\overline{CE})	2
Playback/Record Input (P/ \overline{R})	3
End-Of-Message / RUN Output (\overline{EOM})	3
Overflow Output (\overline{OVF})	3
Microphone Input (MIC)	3
Microphone Reference Input (MIC REF)	3
Automatic Gain Control Input (AGC)	3
Analog Output (ANA OUT)	3
Analog Input (ANA IN)	4
External Clock Input (XCLK)	4
Speaker Outputs (SP+/SP-)	4
Auxiliary Input (AUX IN)	4
Address/Mode Inputs (Ax/Mx)	5
OPERATIONAL MODES	5
OPERATIONAL MODES DESCRIPTION	6
M0 — Message Cueing	6
M1 — Delete EOM Markers	6
M2 — Unused	6
M3 — Message Looping	6
M4 — Consecutive Addressing	6
M5 — \overline{CE} -Level Activated	6
M6 — Push-Button Mode	6
\overline{CE} Pin (START/PAUSE)	7
PD Pin (STOP/RESET)	7
EOM Pin (RUN)	7
Good Audio Design Practices	8
ISD1000A COMPATIBILITY	8
Addressing	8
Overflow	8

Push-Button Mode	8
Looping Mode	8
TIMING DIAGRAMS	9
TYPICAL PARAMETER VARIATION WITH VOLTAGE AND TEMPERATURE (PACKAGED PARTS)	13
TYPICAL PARAMETER VARIATION WITH VOLTAGE AND TEMPERATURE (DIE)	17
EXPLANATION	19
PUSH-BUTTON TIMING DIAGRAMS	22
DEVICE PHYSICAL DIMENSIONS	23
ORDERING INFORMATION	30

FIGURES, CHARTS, AND TABLES IN THE ISD2560/75/90/120 PRODUCTS DATASHEET

Figure 1:	ISD2560/75/90/120 Device Pinouts	2
Figure 2:	Record	9
Figure 3:	Playback	9
Figure 4:	ISD2560/75/90/120 Application Example—Design Schematic	18
Figure 5:	ISD2560/75/90/120 Application Example—Microcontroller/ISD2500 Interface	20
Figure 6:	ISD2500 Application Example—Push-Button	20
Figure 7:	Push-Button Mode Record	22
Figure 8:	Push-Button Mode Playback	22
Figure 9:	28-Lead 8x13.4mm Plastic Thin Small Outline Package (TSOP) Type I (E)	23
Figure 10:	28-Lead 0.600-Inch Plastic Dual Inline Package (PDIP) (P)	24
Figure 11:	32-Lead 8x20mm Plastic Thin Small Outline Package (TSOP) Type I (T)	26
Figure 12:	ISD2560/75/90/120 Products <i>Current</i> Bonding Physical Layout (Unpackaged Die)	27
Figure 13:	ISD2560/75/90/120 Products <i>Future</i> Bonding Physical Layout (Unpackaged Die)	29
Chart 1:	Record Mode Operating Current (I_{CC})	13
Chart 2:	Total Harmonic Distortion	13
Chart 3:	Standby Current (I_{SB})	13
Chart 4:	Oscillator Stability	13
Chart 5:	Record Mode Operating Current (I_{CC})	17
Chart 6:	Total Harmonic Distortion	17
Chart 7:	Standby Current (I_{SB})	17
Chart 8:	Oscillator Stability	17
Table 1:	External Clock Sample Rates	4
Table 2:	Operational Modes Table	5
Table 3:	Alternate Functionality in Pins	6
Table 4:	Absolute Maximum Ratings (Packaged Parts)	10
Table 5:	Operating Conditions (Packaged Parts)	10
Table 6:	DC Parameters (Packaged Parts)	10
Table 7:	AC Parameters (Packaged Parts)	11
Table 8:	Absolute Maximum Ratings (Die)	14
Table 9:	Operating Conditions (Die)	14
Table 10:	DC Parameters (Die)	14
Table 11:	AC Parameters (Die)	15
Table 12:	Application Example—Basic Device Control	18
Table 13:	Application Example—Passive Component Functions	19
Table 14:	Application Example—Push-Button Control	21
Table 15:	Application Example—Passive Component Functions	21
Table 16:	Push-Button Parameters	21
Table 17:	Plastic Thin Small Outline Package (TSOP) Type I (E) Dimensions	23
Table 18:	Plastic Dual Inline Package (PDIP) (P) Dimensions	24
Table 19:	Plastic Thin Small Outline Package (TSOP) Type I (T) Dimensions	26
Table 20:	ISD2560/75/90/120 Products <i>Current</i> PIN/PAD Designations	28
Table 21:	ISD2560/75/90/120 Products <i>Future</i> PIN/PAD Designations	30

