

INTELLIGENT HIGH SIDE MOSFET POWER SWITCH

Features

- Over-Temperature Protection
- Active Output Negative Clamp
- Reverse Battery Protection for Logic Circuit
- Broken Ground Protection
- Short to VCC Protection
- Low Noise Charge Pump
- Sleep Mode Supply Current
- 4kV ESD Protection On All Pins
- Logic Ground Isolated From Power Ground

$V_{cc(op)}$	5v-50v
$R_{ds(on)}$	85m Ω
I_{lim}	10A
$T_{j(sd)}$	170°C
E_{av}	100mJ

General Description

The IPS521G is a monolithic HIGH SIDE SWITCH with built in short circuit, over- temperature, ESD, inductive load turn off capability and diagnostic feedback.

The on-chip protection circuit goes into current limiting mode and limits the average current during short circuit if the drain current exceeds 10A. The protection circuit latches off the high side switch if the junction temperature exceeds 170°C and latches on after the junction temperature falls by 10°C. The Vcc (drain) to OUT (source) voltage is actively clamped at 55V, improving its performance during turn off with inductive loads.

The on-chip charge pump high side driver stage is floating and referenced to the source of the power MOSFET. Thus the logic to power ground isolation can be as high as 50V. This allows operation with larger offset as well as controlling the switch during load energy recirculation or regeneration.

A diagnostic pin is provided for status feedback of short circuit, over temperature and open load detection.

Applications

- Solenoid Driver
- Programmable Logic Controller

Truth Table

Condition	In	Out	Dg
Normal	H	H	H
Normal	L	L	L
Output Open	H	H	H
Output Open	L	H	H
Shorted Output	H	Current-Limiting	L
Shorted Output	L	L	L
Over-Temperature	H	L	L
Over-Temperature	L	L	L

Block Diagram

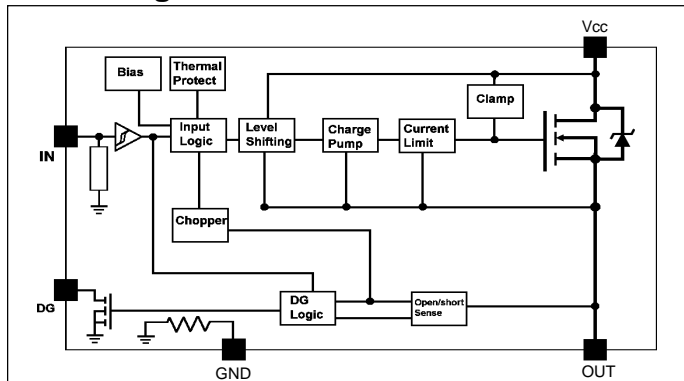

Available Packages

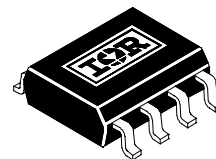

8 Lead SOIC

Absolute Maximum Ratings

Absolute Maximum Ratings indicate sustained limits beyond which damage to the device may occur. ($T_C = 25^\circ\text{C}$ unless otherwise specified.)

Symbol	Parameter	Min.	Max.	Units	Test Conditions
V _{cc}	Supply Voltage	-0.3	50	V	Pin 5 to Pin 3 (1), for 10 seconds
	Permanent Reverse	-16	—		
V _{offset}	Logic to Power Ground Offset	V _{cc} -50	V _{cc} +0.3		
V _{in}	Input Voltage	-0.3	7		
I _{in}	Input Current	—	10	mA	
V _{out}	Output Voltage	V _{cc} -50	V _{cc} +0.3	V	
I _{out}	Output Current	—	self-limited	A	
V _{dg}	Diagnostic Output Voltage	-0.3	7	V	
I _{dg}	Diagnostic Output Current	—	10	mA	
E _{av}	Repetitive Avalanche Energy	—	100	mJ	I = 2A(2)
ESD1	Electrostatic Discharge (Human Body Model)	—	4000	V	C=100 pF, R = 1500Ω
ESD2	Electrostatic Discharge (Machine Model)	—	500	V	C=200 pF, R = 0Ω
PD	Power Dissipation	—	2	W	T _{ambient} =25°C
T _{Jop}	Operating Junction Temperature Range	-40	150	°C	
T _{Stg}	Storage Temperature Range	-40	150		

NOTES:(1) with 15k Ω resistors in input and diagnostic (2) maximum frequency depends on heatsink (rectangular waveform)

Static Electrical Characteristics

($T_C = 25^\circ\text{C}$ and $V_{CC} = 16\text{V}$ unless otherwise specified.)

Symbol	Parameter	Min.	Typ.	Max.	Units	Test Conditions
V _{ccop}	Operating Voltage Range	5	—	50	V	
I _{ccoff}	Sleep Mode Supply Current	—	30	—	μA	V _{cc} =24V, V _{in} =0V
I _{ccon}	Supply Current (Average)	—	1	—	mA	V _{in} = 5V
I _{ccac}	Supply Current (AC RMS)	—	20	—	μA	V _{in} = 5V
V _{ih}	High Level Input Threshold Voltage	—	2	2.5	V	
V _{il}	Low Level Input Threshold Voltage	1	1.8	—		
I _{ion}	On-State Input Current	10	—	140	μA	V _{in} = 5.5V
I _{ioff}	Off-State Input Current	1	—	30		V _{in} = 0.4V
I _{oh}	Output Leakage Current	—	20	—		V _{out} = 6V
I _{ol}	Output Leakage Current	0	—	10		V _{out} = 0V
V _{dgl}	Low Level Diagnostic Output Voltage	—	0.3	—	V	I _{dg} = 1.6mA
I _{dg}	Diagnostic Output Leakage Current	0	—	10	μA	V _{dg} = 5V
R _{DS(on)}	On-State Resistance	—	70	85	mΩ	I _{out} = 2A

Switching Electrical Characteristics

(V_{CC} = 14V, Resistive Load (R_L) = 12Ω, T_C = 25°C.)

Symbol	Parameter	Min.	Typ.	Max.	Units	Test Conditions
t _{on}	Turn-On Delay Time to 90%	—	100	—	μs	
t _{off}	Turn-Off Delay Time to 10%	—	120	—		
dv/dt _{on}	Slew Rate On	—	3	—	V/μs	
dv/dt _{off}	Slew Rate Off	—	5	—		

Protection Characteristics

Symbol	Parameter	Min.	Typ.	Max.	Units	Test Conditions
I _{lim}	Internal Current Limit	—	10	—	A	
V _{sc}	Short Circuit Detection Voltage	—	3.0	—	V	
V _{slh}	Open Load Detection Voltage	—	3.0	—		
V _{cl1}	Output Negative Clamp	40	54	—		I _{out} = 10mA
V _{cl2}	Output Negative Clamp	—	56	62		I _{out} = 2A

Thermal Characteristics

Symbol	Parameter	Min.	Typ.	Max.	Units	Test Conditions
T _{jsd}	Thermal Shutdown Temperature	—	170	—	°C	
T _{hys}	Thermal Hysteresis	—	10	—		
R _{thjc}	Thermal Resistance, Junction to PCB	—	60	—	°C/W	
R _{thjA}	Thermal Resistance, Junction to Ambient	—	80	—		

Pin Assignment

Pin # 1	Pin # 2	Pin #3	Pin #4	Pin #5	Pin #6	Pin #7	Pin #8
GND	IN	DG	OUT (source)	Vcc	Vcc	Vcc	Vcc

Case Outline

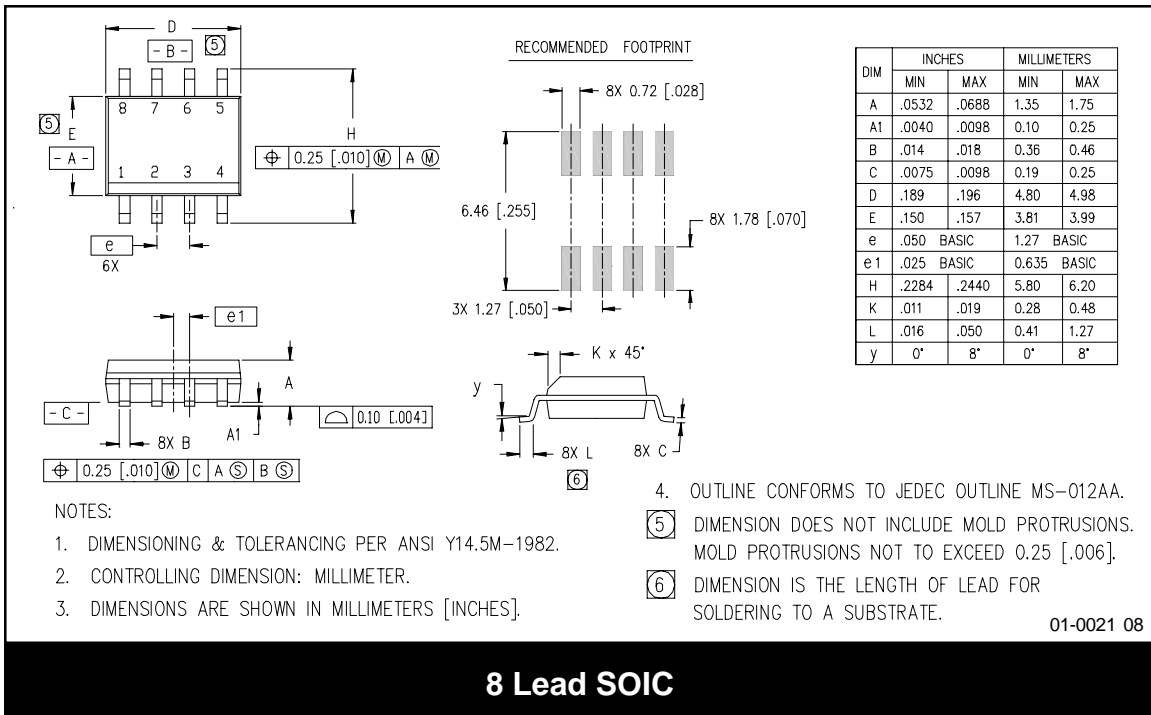

01-0021 08