

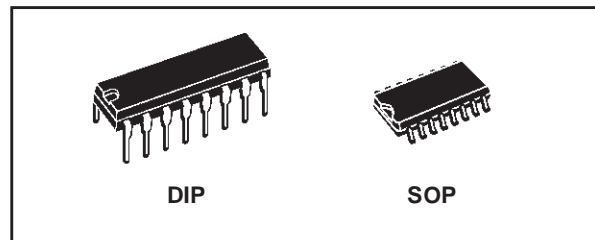

# HCF4089B

## BINARY RATE MULTIPLIER

- CASCADABLE IN MULTIPLES OF 4-BITS
- SET TO "15" INPUT AND "15" DETECT OUTPUT
- QUIESCENT CURRENT SPECIFIED UP TO 20V
- STANDARDIZED SYMMETRICAL OUTPUT CHARACTERISTICS
- 5V, 10V AND 15V PARAMETRIC RATINGS
- INPUT LEAKAGE CURRENT  
 $I_l = 100\text{nA (MAX) AT } V_{DD} = 18\text{V } T_A = 25^\circ\text{C}$
- 100% TESTED FOR QUIESCENT CURRENT
- MEETS ALL REQUIREMENTS OF JEDEC JESD13B "STANDARD SPECIFICATIONS FOR DESCRIPTION OF B SERIES CMOS DEVICES"



### ORDER CODES

PACKAGE	TUBE	T & R
DIP	HCF4089BEY	
SOP	HCF4089BM1	HCF4089M013TR

### DESCRIPTION

HCF4089B is a monolithic integrated circuit fabricated in Metal Oxide Semiconductor technology available in DIP and SOP packages. HCF4089B is a low power 4-bit digital rate multiplier that provides an output pulse rate that is the clock input pulse rate multiplied by 1/16 times the binary input. For example, when the binary input number is 13, there will be 13 output pulses for every 16 input pulses. HCF4089B has an internal synchronous 4-bit counter, which, together with one of the four

binary inputs bits, produces pulse trains as shown in the timing diagram.

If more than one binary input bit is high, the resulting pulse train is a combination of the above separate pulse trains. This device may be used to perform arithmetic operations (add, subtract, divide, raise to a power), solve algebraical and differential equations, generate natural logarithms and trigonometric functions, A/D and D/A conversions, and frequency division.

### PIN CONNECTION

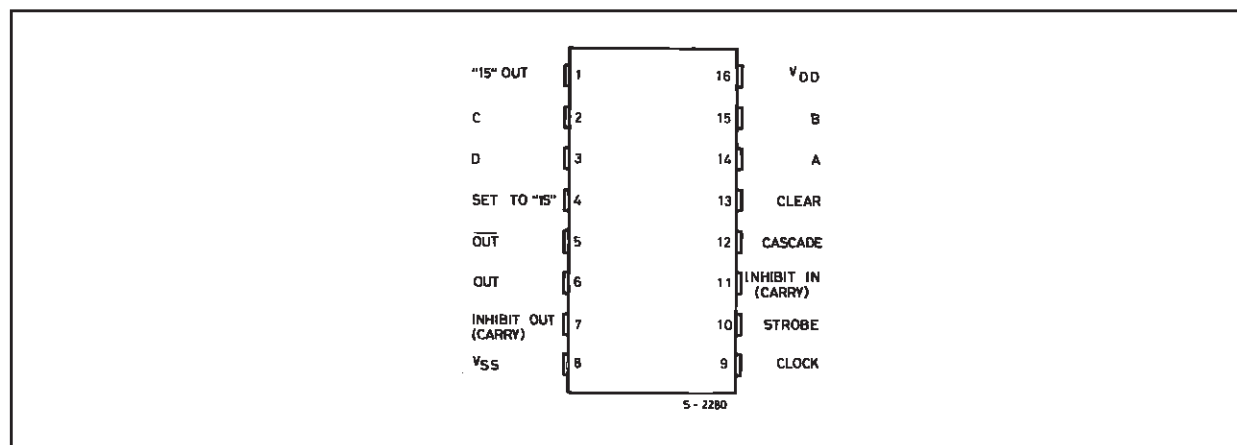

INPUT EQUIVALENT CIRCUIT

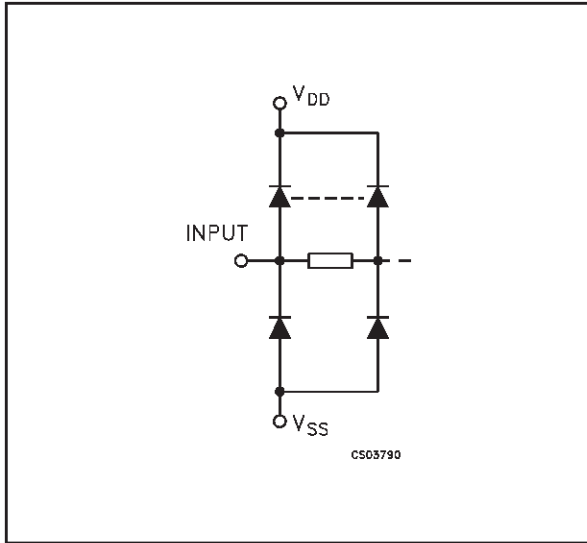

PIN DESCRIPTION

PIN No	SYMBOL	NAME AND FUNCTION
14, 15, 2, 3	A, B, C, D	Binary Rate Select Inputs
5	OUT	Rate Output
6	OUT	Rate Output
4	SET TO "15"	Set Input
1	"15" OUT	Output
7	INHIBIT OUT (CARRY)	Inhibit Out (Carry)
13	CLEAR	Clear Input
12	CASCADE	Cascade
11	INHIBIT IN (CARRY)	Inhibit Input (Carry)
10	STROBE	Strobe
9	CLOCK	Clock Input
8	V <sub>SS</sub>	Negative Supply Voltage
16	V <sub>DD</sub>	Positive Supply Voltage

FUNCTIONAL DIAGRAM

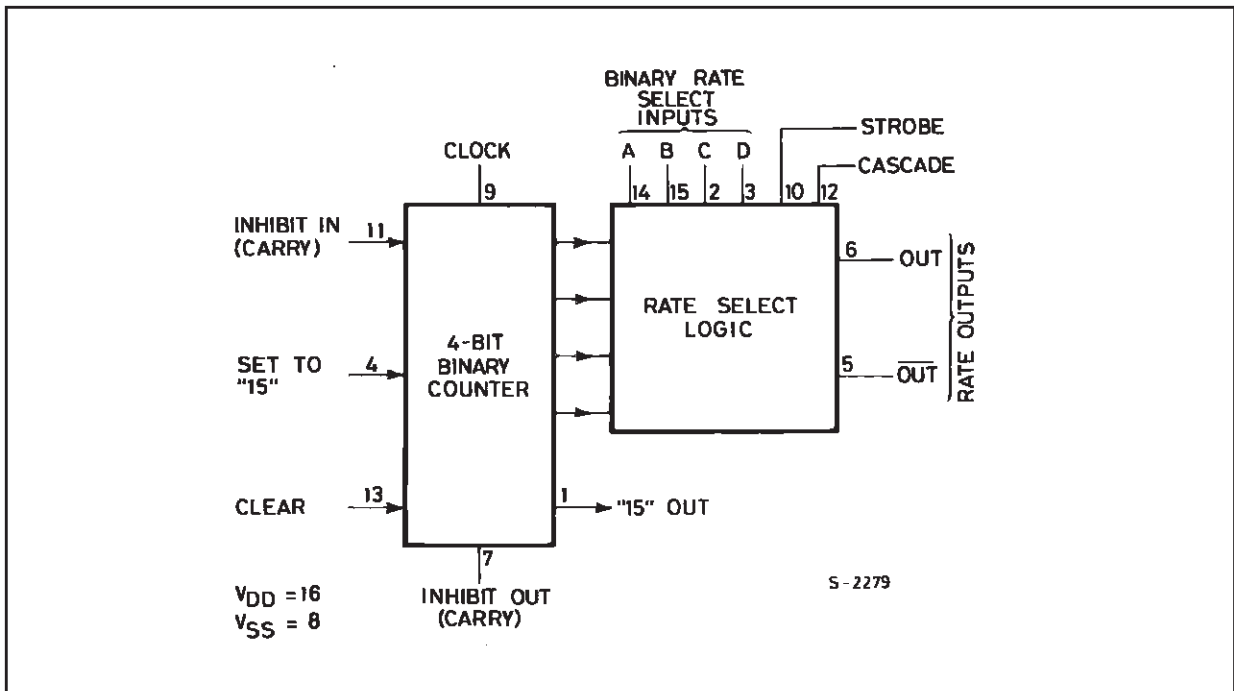

TRUTH TABLE

INPUTS										OUTPUTS			
Number of Pulses or Input Logic Level										Number of Pulses or Output Logic Level			
D	C	B	A	CLOCK	INH IN	STR.	CAS.	CLEAR	SET	OUT	$\overline{\text{OUT}}$	INH OUT	"15" OUT
L	L	L	L	16	L	L	L	L	L	L	H	1	1
L	L	L	H	16	L	L	L	L	L	1	1	1	1
L	L	H	L	16	L	L	L	L	L	2	2	1	1
L	L	H	H	16	L	L	L	L	L	3	3	1	1
L	H	L	L	16	L	L	L	L	L	4	4	1	1
L	H	L	H	16	L	L	L	L	L	5	5	1	1
L	H	H	L	16	L	L	L	L	L	6	6	1	1
L	H	H	H	16	L	L	L	L	L	7	7	1	1
H	L	L	L	16	L	L	L	L	L	8	8	1	1
H	L	L	H	16	L	L	L	L	L	9	9	1	1
H	L	H	L	16	L	L	L	L	L	10	10	1	1
H	L	H	H	16	L	L	L	L	L	11	11	1	1
H	H	L	L	16	L	L	L	L	L	12	12	1	1
H	H	L	H	16	L	L	L	L	L	13	13	1	1
H	H	H	L	16	L	L	L	L	L	14	14	1	1
H	H	H	H	16	L	L	L	L	L	15	15	1	1
X	X	X	X	16	H	L	L	L	L	•	•	H	•
X	X	X	X	16	L	H	L	L	L	L	H	1	1
X	X	X	X	16	L	L	H	L	L	H	*	1	1
H	X	X	X	16	L	L	L	H	L	16	16	H	L
L	X	X	X	16	L	L	L	H	L	L	H	H	L
X	X	X	X	16	L	L	L	L	H	L	H	L	H

X : Don't Care

• : Depends on internal state of counter

\*: Output same as the first 16 lines of this truth table (depending on values of A, B, C, D)

LOGIC DIAGRAM

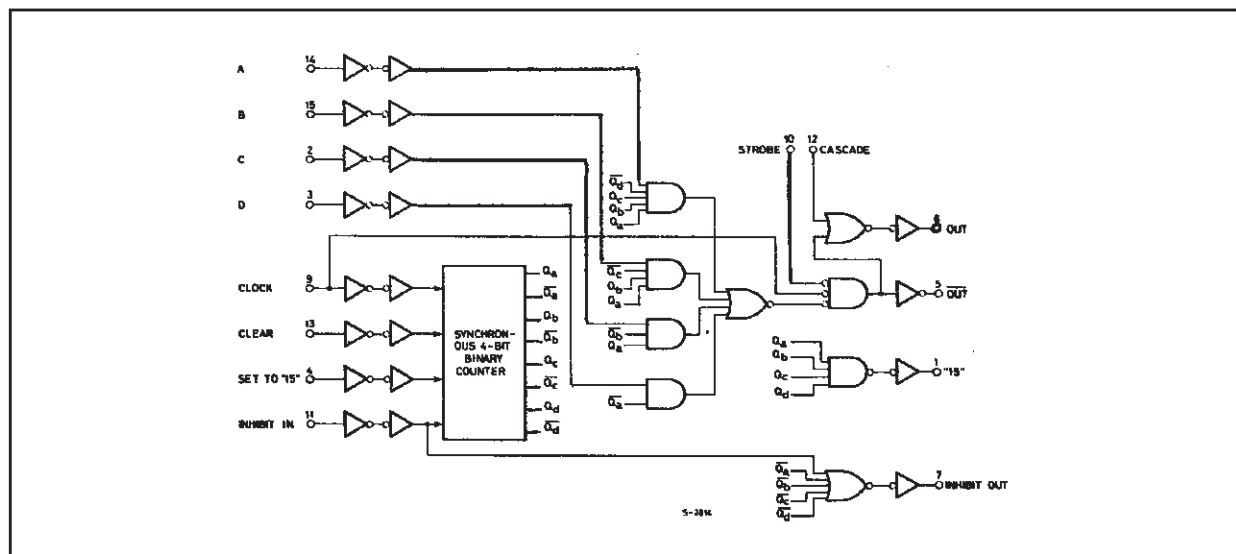

TIMING CHART

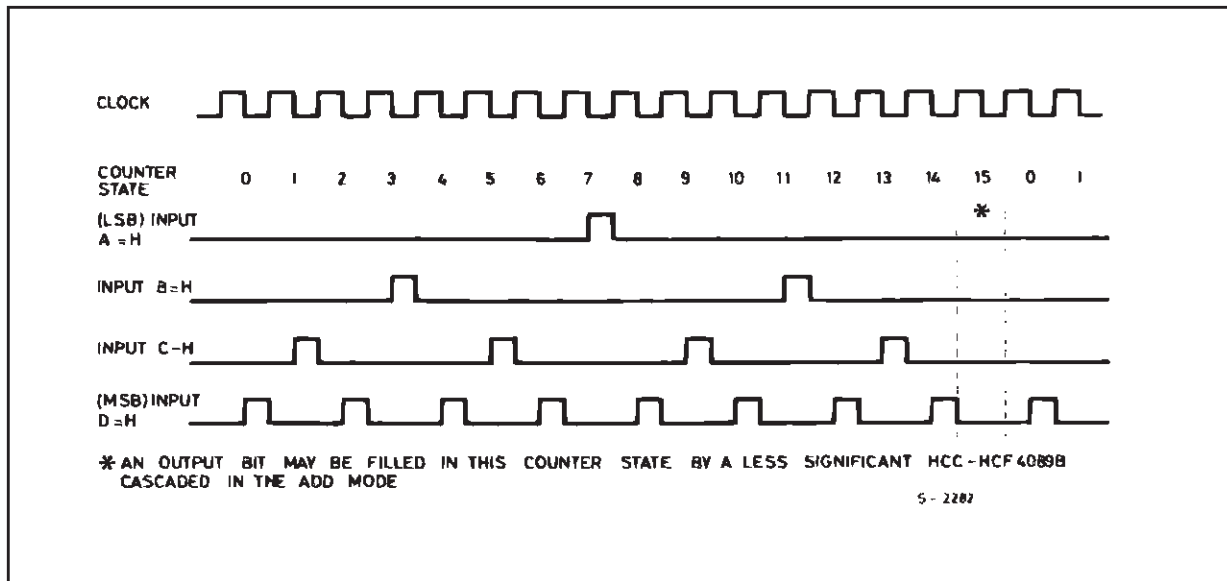

ABSOLUTE MAXIMUM RATINGS

Symbol	Parameter	Value	Unit
V <sub>DD</sub>	Supply Voltage	-0.5 to +22	V
V <sub>I</sub>	DC Input Voltage	-0.5 to V <sub>DD</sub> + 0.5	V
I <sub>I</sub>	DC Input Current	± 10	mA
P <sub>D</sub>	Power Dissipation per Package	200	mW
	Power Dissipation per Output Transistor	100	mW
T <sub>op</sub>	Operating Temperature	-55 to +125	°C
T <sub>stg</sub>	Storage Temperature	-65 to +150	°C

Absolute Maximum Ratings are those values beyond which damage to the device may occur. Functional operation under these conditions is not implied.

All voltage values are referred to V<sub>SS</sub> pin voltage.

RECOMMENDED OPERATING CONDITIONS

Symbol	Parameter	Value	Unit
V <sub>DD</sub>	Supply Voltage	3 to 20	V
V <sub>I</sub>	Input Voltage	0 to V <sub>DD</sub>	V
T <sub>op</sub>	Operating Temperature	-55 to 125	°C

## DC SPECIFICATIONS

Symbol	Parameter	Test Condition				Value						Unit	
		V <sub>I</sub> (V)	V <sub>O</sub> (V)	I <sub>O</sub>   ( $\mu$ A)	V <sub>DD</sub> (V)	T <sub>A</sub> = 25°C			-40 to 85°C		-55 to 125°C		
						Min.	Typ.	Max.	Min.	Max.	Min.		Max.
I <sub>L</sub>	Quiescent Current	0/5			5		0.04	5		150		150	$\mu$ A
		0/10			10		0.04	10		300		300	
		0/15			15		0.04	20		600		600	
		0/20			20		0.08	100		3000		3000	
V <sub>OH</sub>	High Level Output Voltage	0/5		<1	5	4.95			4.95		4.95		V
		0/10		<1	10	9.95			9.95		9.95		
		0/15		<1	15	14.95			14.95		14.95		
V <sub>OL</sub>	Low Level Output Voltage	5/0		<1	5		0.05			0.05		0.05	V
		10/0		<1	10		0.05			0.05		0.05	
		15/0		<1	15		0.05			0.05		0.05	
V <sub>IH</sub>	High Level Input Voltage		0.5/4.5	<1	5	3.5			3.5		3.5		V
			1/9	<1	10	7			7		7		
			1.5/13.5	<1	15	11			11		11		
V <sub>IL</sub>	Low Level Input Voltage		4.5/0.5	<1	5			1.5		1.5		1.5	V
			9/1	<1	10			3		3		3	
			13.5/1.5	<1	15			4		4		4	
I <sub>OH</sub>	Output Drive Current	0/5	2.5	<1	5	-1.36	-3.2		-1.1		-1.1		mA
		0/5	4.6	<1	5	-0.44	-1		-0.36		-0.36		
		0/10	9.5	<1	10	-1.1	-2.6		-0.9		-0.9		
		0/15	13.5	<1	15	-3.0	-6.8		-2.4		-2.4		
I <sub>OL</sub>	Output Sink Current	0/5	0.4	<1	5	0.44	1		0.36		0.36		mA
		0/10	0.5	<1	10	1.1	2.6		0.9		0.9		
		0/15	1.5	<1	15	3.0	6.8		2.4		2.4		
I <sub>I</sub>	Input Leakage Current	0/18	Any Input		18		$\pm 10^{-5}$	$\pm 0.1$		$\pm 1$		$\pm 1$	$\mu$ A
C <sub>I</sub>	Input Capacitance		Any Input				5	7.5					pF

The Noise Margin for both "1" and "0" level is: 1V min. with V<sub>DD</sub>=5V, 2V min. with V<sub>DD</sub>=10V, 2.5V min. with V<sub>DD</sub>=15V

DYNAMIC ELECTRICAL CHARACTERISTICS (T<sub>amb</sub> = 25°C, C<sub>L</sub> = 50pF, R<sub>L</sub> = 200K $\Omega$ , t<sub>r</sub> = t<sub>f</sub> = 20 ns)

Symbol	Parameter	Test Condition		Value (*)			Unit
		V <sub>DD</sub> (V)		Min.	Typ.	Max.	
t <sub>PHL</sub> t <sub>PLH</sub>	Propagation Delay Time CLOCK to OUT	5			110	220	ns
		10			55	110	
		15			45	90	
t <sub>PHL</sub> t <sub>PLH</sub>	Propagation Delay Time CLOCK or STROBE to OUT	5			150	300	ns
		10			75	150	
		15			60	120	
t <sub>PHL</sub> t <sub>PLH</sub>	Propagation Delay Time CLOCK to INHIBIT High Level to Low Level	5			360	720	ns
		10			160	320	
		15			110	220	
t <sub>PHL</sub> t <sub>PLH</sub>	Propagation Delay Time LOW Level to HIGH Level	5			250	500	ns
		10			100	200	
		15			75	150	

## HCF4089B

Symbol	Parameter	Test Condition		Value (*)			Unit
		V <sub>DD</sub> (V)		Min.	Typ.	Max.	
t <sub>PHL</sub> t <sub>PLH</sub>	Propagation Delay Time CLEAR to OUT	5			380	760	ns
		10			175	350	
		15			130	260	
t <sub>PHL</sub> t <sub>PLH</sub>	Propagation Delay Time CLOCK to "9" or "15" OUT	5			300	600	ns
		10			125	250	
		15			90	180	
t <sub>PHL</sub> t <sub>PLH</sub>	Propagation Delay Time CASCADE to OUT	5			90	180	ns
		10			45	90	
		15			35	70	
t <sub>PHL</sub> t <sub>PLH</sub>	Propagation Delay Time INHIBIT IN to INHIBIT OUT	5			160	320	ns
		10			75	150	
		15			55	110	
t <sub>PHL</sub> t <sub>PLH</sub>	Propagation Delay Time SET to OUT	5			330	660	ns
		10			150	300	
		15			110	220	
t <sub>THL</sub> t <sub>TLH</sub>	Transition Time	5			100	200	ns
		10			50	100	
		15			40	80	
f <sub>CL</sub>	Maximum Clock Frequency	5		1.2	2.4		MHz
		10		2.5	5		
		15		3.5	7		
t <sub>W</sub>	Clock Pulse Width	5		330	165		ns
		10		170	85		
		15		100	50		
t <sub>r</sub> , t <sub>f</sub>	Clock Rise or Fall Time	5				15	μs
		10				15	
		15				15	
t <sub>W</sub>	SET or CLEAR pulse Width	5		160	80		ns
		10		90	45		
		15		60	30		
t <sub>setup</sub>	INHIBIT Input Set-Up Time, High Level to Low Level	5		100	50		ns
		10		40	20		
		15		20	10		
t <sub>R</sub>	INHIBIT Input Removal Time	5		240	120		ns
		10		130	65		
		15		110	55		
t <sub>R</sub>	Minimum SET Removal Time	5		150	75		ns
		10		80	40		
		15		50	25		
t <sub>R</sub>	CLEAR Removal Time	5		60	30		ns
		10		40	20		
		15		30	15		

(\*) Typical temperature coefficient for all V<sub>DD</sub> value is 0.3 %/°C.

**APPLICATION NOTES**

For words of more than 4 bits, HCF4089B device may be cascaded in two different modes : an ADD mode and a MULTIPLY mode.

**TWO HCF4089B'S CASCADED IN THE "ADD" MODE WITH A PRESET NUMBER OF 189**

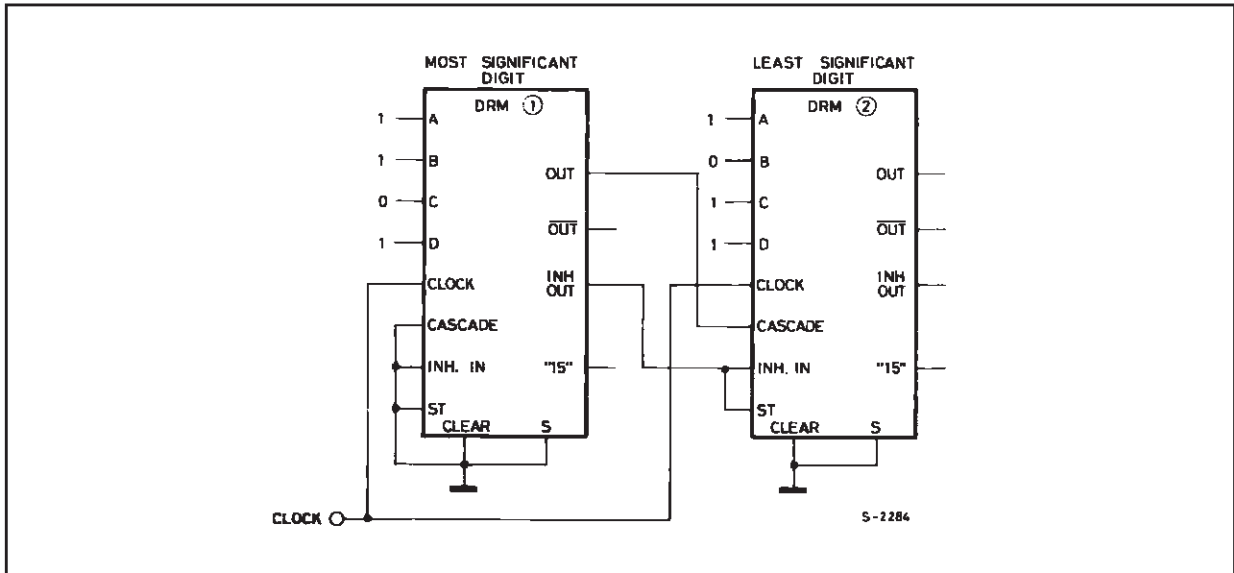

In the ADD mode some of the gaps left by the more significant unit at the count of 15 are filled in by the less significant units. For example, when two units are cascaded in the ADD mode and programmed to 11 and 13, respectively, the more significant unit will have 11 output pulses and the other unit will have 13 output pulses for every 256 input pulses for a total of :

$$\frac{11}{16} + \frac{13}{256} = \frac{189}{256}$$

**TWO HCF4089B'S CASCADED IN THE "MULTIPLY" MODE FOR MULTIPLICATION OF TWO VARIABLES A AND B WITH LOOP CIRCUIT CONTROL**

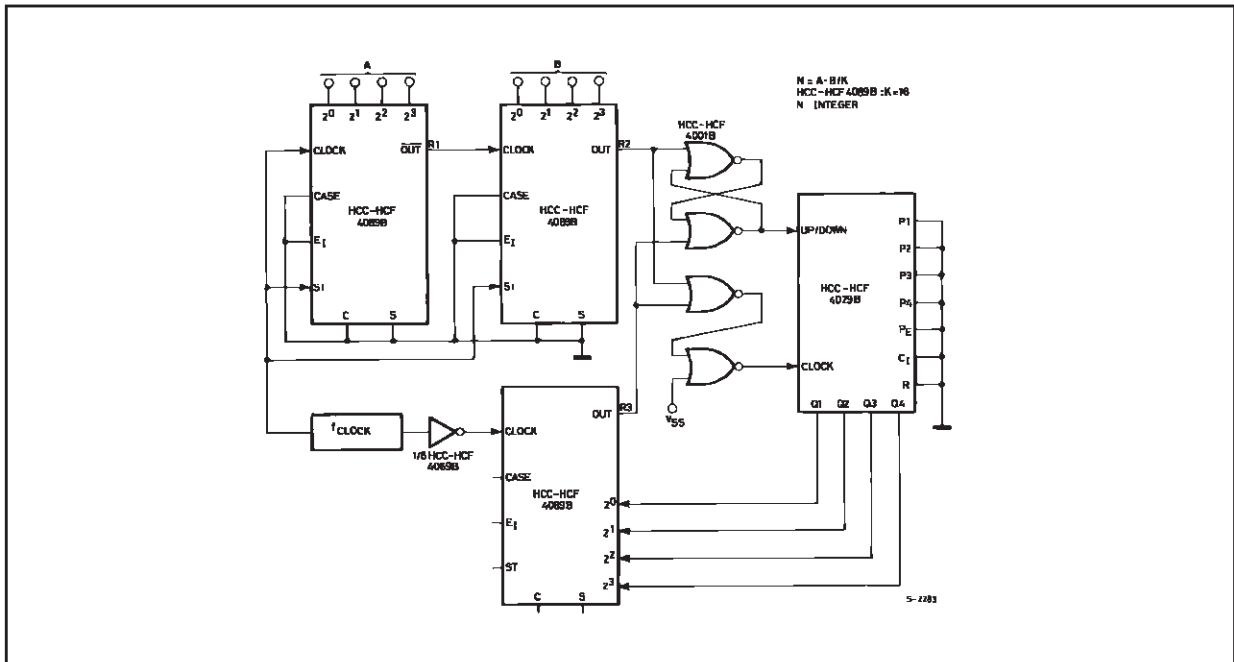

When the loop stabilizes rate  $R_2 = \text{rate } R_3$ , thus  $f_{\text{clock}} \left( \frac{A}{16} \cdot \frac{B}{16} \right) = f_{\text{clock}} \left( \frac{1}{16} \cdot \frac{N}{16} \right)$  therefore  $N = AB$

TEST CIRCUIT

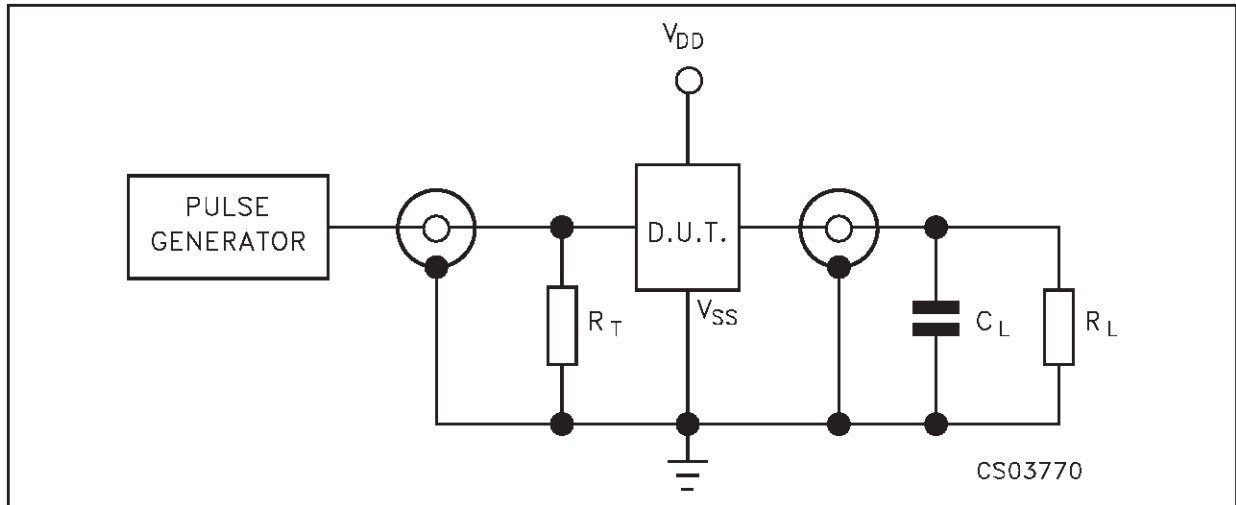

$C_L = 50\text{pF}$  or equivalent (includes jig and probe capacitance)  
 $R_L = 200\text{K}\Omega$   
 $R_T = Z_{OUT}$  of pulse generator (typically  $50\Omega$ )



### Plastic DIP-16 (0.25) MECHANICAL DATA

DIM.	mm.			inch		
	MIN.	TYP	MAX.	MIN.	TYP.	MAX.
a1	0.51			0.020		
B	0.77		1.65	0.030		0.065
b		0.5			0.020	
b1		0.25			0.010	
D			20			0.787
E		8.5			0.335	
e		2.54			0.100	
e3		17.78			0.700	
F			7.1			0.280
I			5.1			0.201
L		3.3			0.130	
Z			1.27			0.050

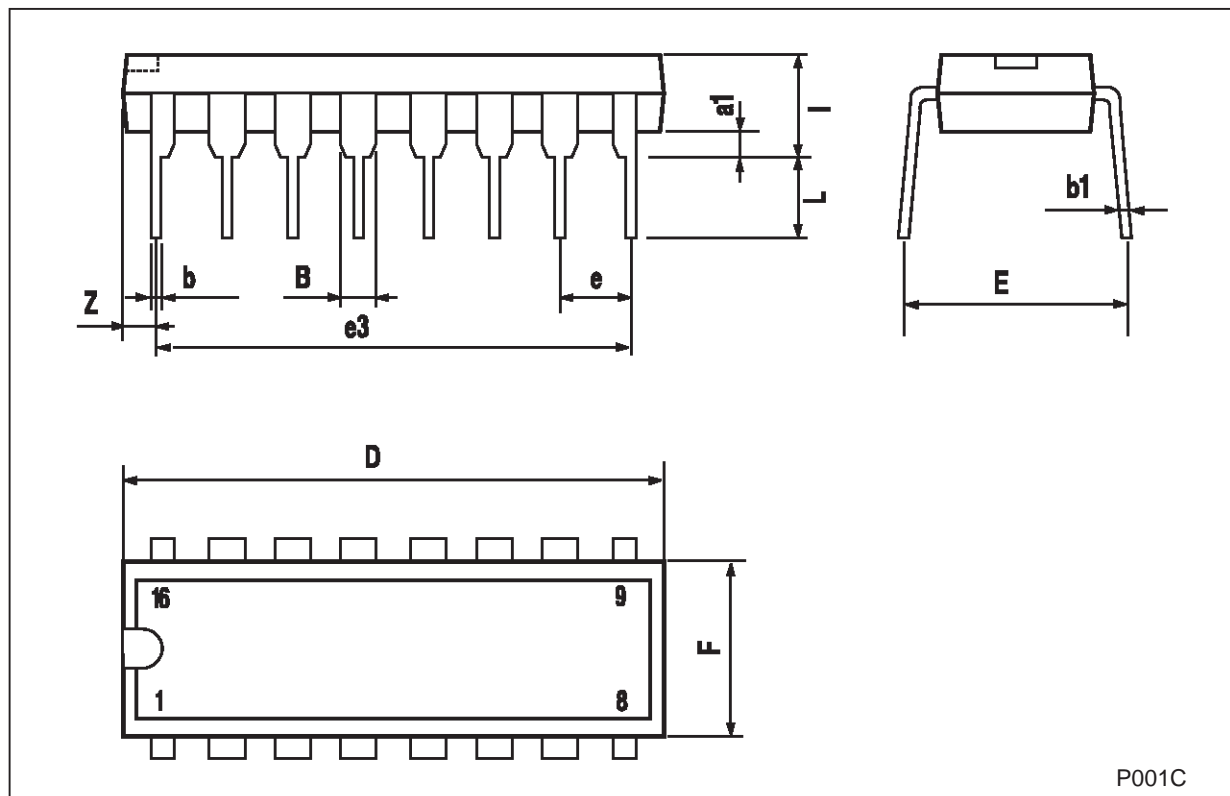

## SO-16 MECHANICAL DATA

DIM.	mm.			inch		
	MIN.	TYP.	MAX.	MIN.	TYP.	MAX.
A			1.75			0.068
a1	0.1		0.2	0.003		0.007
a2			1.65			0.064
b	0.35		0.46	0.013		0.018
b1	0.19		0.25	0.007		0.010
C		0.5			0.019	
c1	45° (typ.)					
D	9.8		10	0.385		0.393
E	5.8		6.2	0.228		0.244
e		1.27			0.050	
e3		8.89			0.350	
F	3.8		4.0	0.149		0.157
G	4.6		5.3	0.181		0.208
L	0.5		1.27	0.019		0.050
M			0.62			0.024
S	8° (max.)					

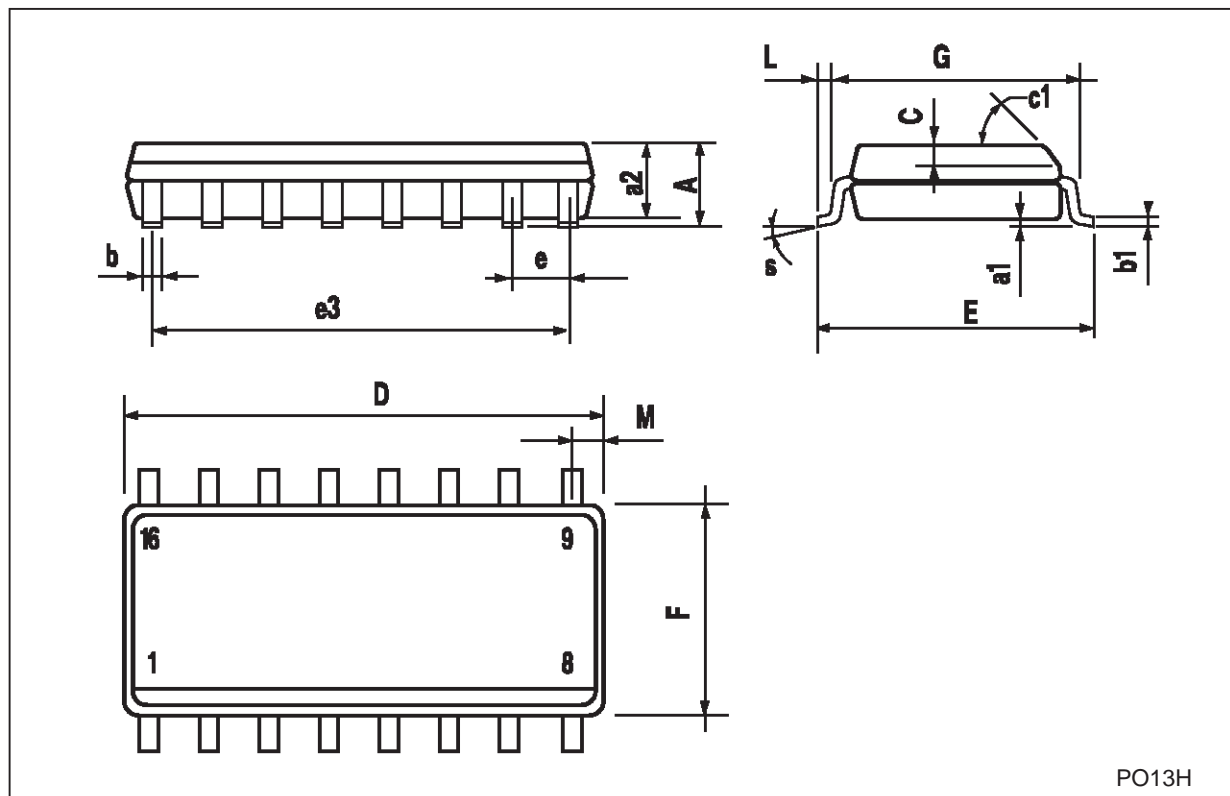

PO13H

Information furnished is believed to be accurate and reliable. However, STMicroelectronics assumes no responsibility for the consequences of use of such information nor for any infringement of patents or other rights of third parties which may result from its use. No license is granted by implication or otherwise under any patent or patent rights of STMicroelectronics. Specifications mentioned in this publication are subject to change without notice. This publication supersedes and replaces all information previously supplied. STMicroelectronics products are not authorized for use as critical components in life support devices or systems without express written approval of STMicroelectronics.

© The ST logo is a registered trademark of STMicroelectronics

© 2002 STMicroelectronics - Printed in Italy - All Rights Reserved  
STMicroelectronics GROUP OF COMPANIES

Australia - Brazil - Canada - China - Finland - France - Germany - Hong Kong - India - Israel - Italy - Japan - Malaysia - Malta - Morocco  
Singapore - Spain - Sweden - Switzerland - United Kingdom - United States.

© <http://www.st.com>

