



HCF40106B

HEX SCHMITT TRIGGER

- SCHMITT TRIGGER ACTION WITH NO EXTERNAL COMPONENTS
- HYSTERESIS VOLTAGE (Typ.) :
 - 0.9V at $V_{DD} = 5V$
 - 2.3V at $V_{DD} = 10V$
 - 3.5V at $V_{DD} = 15V$
- NOISE IMMUNITY GREATER THAN 50%
- NO LIMIT ON INPUT RISE AND FALL TIME
- LOW V_{DD} TO V_{SS} CURRENT DURING SLOW INPUT RAMP
- STANDARDIZED SYMMETRICAL OUTPUT CHARACTERISTICS
- QUIESCENT CURRENT SPECIFIED UP TO 20V
- 5V, 10V AND 15V PARAMETRIC RATINGS
- INPUT LEAKAGE CURRENT
 - $I_l = 100nA$ (MAX) AT $V_{DD} = 18V$ $T_A = 25^\circ C$
- 100% TESTED FOR QUIESCENT CURRENT
- MEETS ALL REQUIREMENTS OF JEDEC JESD13B "STANDARD SPECIFICATIONS FOR DESCRIPTION OF B SERIES CMOS DEVICES"

DESCRIPTION

The HCF40106B is a monolithic integrated circuit fabricated in Metal Oxide Semiconductor technology available in DIP and SOP packages.

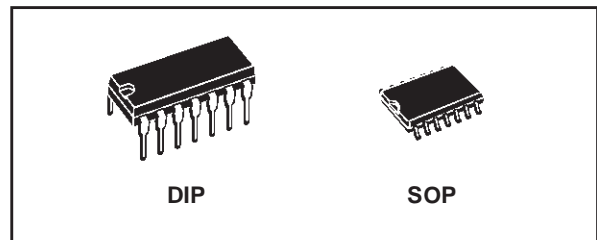

ORDER CODES

PACKAGE	TUBE	T & R
DIP	HCF40106BEY	
SOP	HCF40106BM1	HCF40106M013TR

The HCF40106B consist of six Schmitt trigger circuits. Each circuit functions as an inverter with Schmitt trigger action on the input. The trigger switches at different points for positive and negative going signals. The difference between the positive going voltage (V_P) and the negative going voltage (V_N) is defined as hysteresis voltage (V_H).

PIN CONNECTION

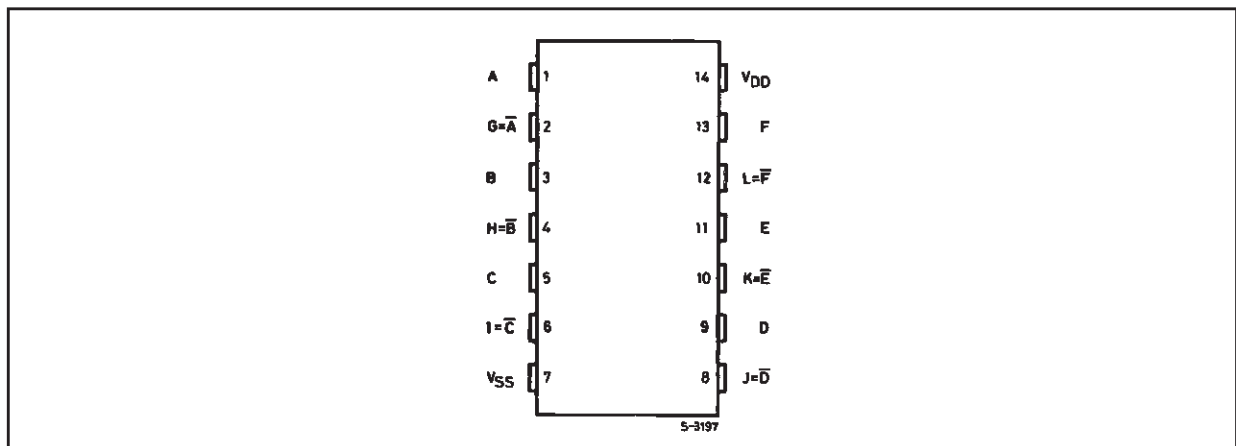

INPUT EQUIVALENT CIRCUIT

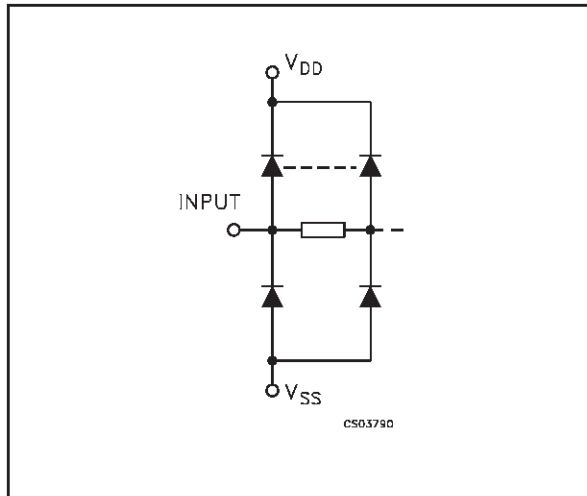

PIN DESCRIPTION

PIN No	SYMBOL	NAME AND FUNCTION
1, 3, 5, 9, 11, 13	A, B, C, D, E, F	Data Inputs
2, 4, 6, 8, 10, 12	G, H, I, J, K, L	Data Outputs
7	V_{SS}	Negative Supply Voltage
14	V_{DD}	Positive Supply Voltage

TRUTH TABLE

INPUTS	OUTPUTS
A to F	G to L
L	H
H	L

FUNCTIONAL DIAGRAM

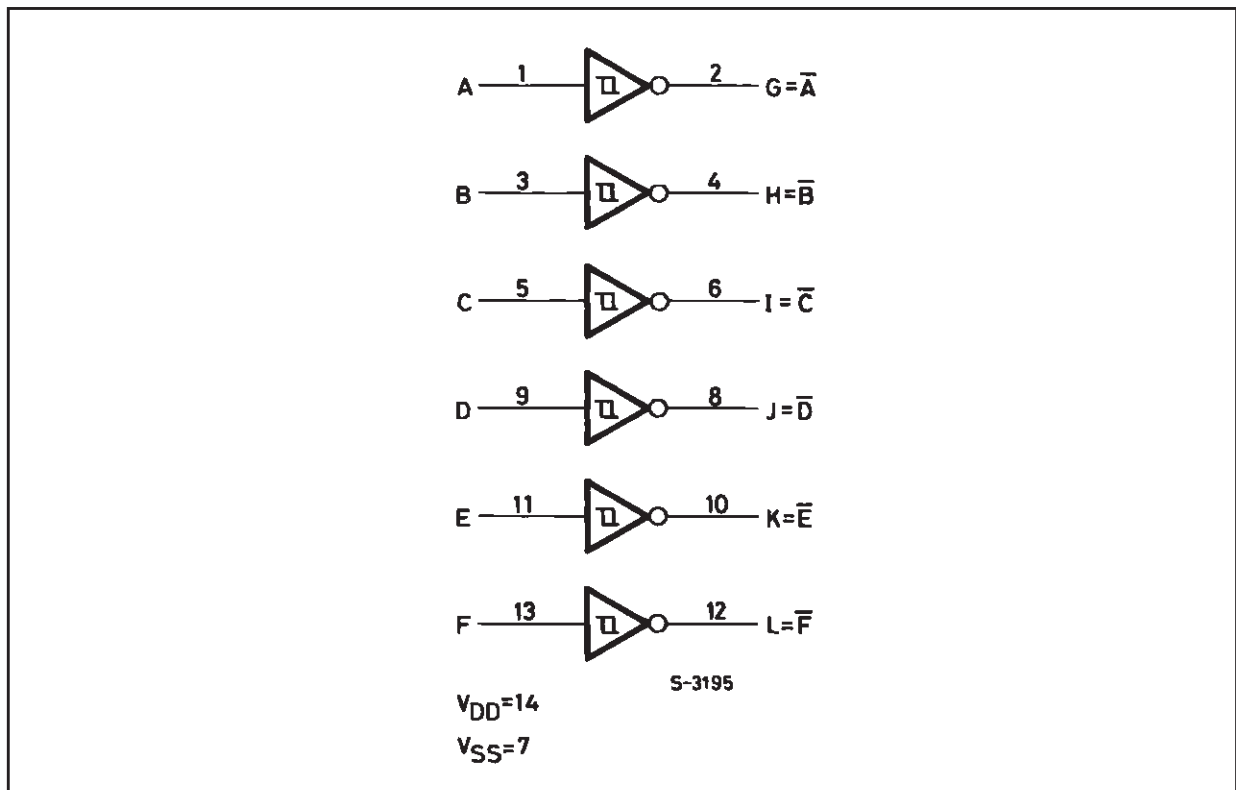

LOGIC DIAGRAM

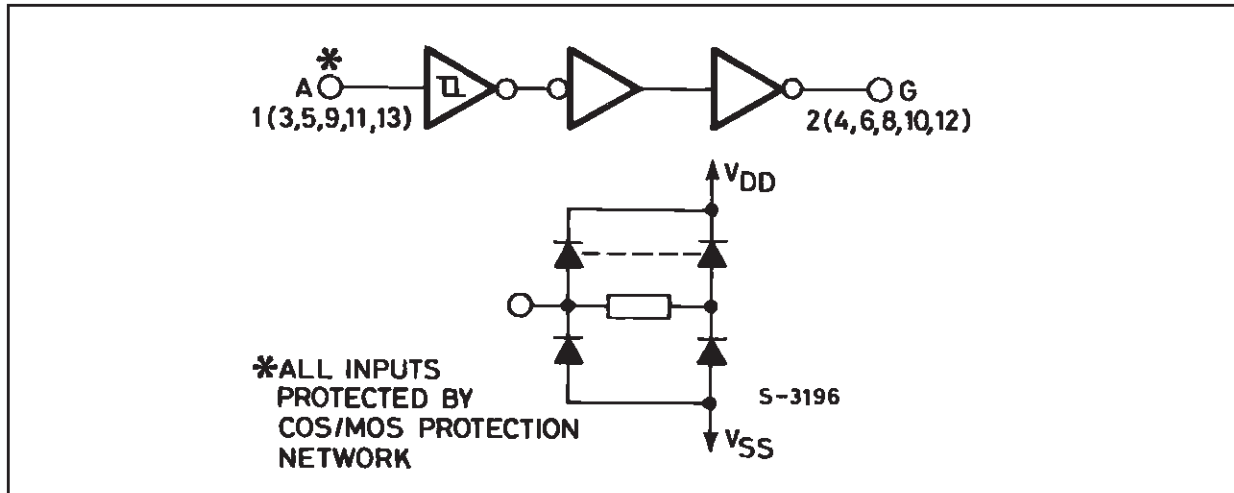

ABSOLUTE MAXIMUM RATINGS

Symbol	Parameter	Value	Unit
V_{DD}	Supply Voltage	-0.5 to +22	V
V_I	DC Input Voltage	-0.5 to $V_{DD} + 0.5$	V
I_I	DC Input Current	± 10	mA
P_D	Power Dissipation per Package	200	mW
	Power Dissipation per Output Transistor	100	mW
T_{op}	Operating Temperature	-55 to +125	$^{\circ}\text{C}$
T_{stg}	Storage Temperature	-65 to +150	$^{\circ}\text{C}$

Absolute Maximum Ratings are those values beyond which damage to the device may occur. Functional operation under these conditions is not implied.

All voltage values are referred to V_{SS} pin voltage.

RECOMMENDED OPERATING CONDITIONS

Symbol	Parameter	Value	Unit
V_{DD}	Supply Voltage	3 to 20	V
V_I	Input Voltage	0 to V_{DD}	V
T_{op}	Operating Temperature	-55 to 125	$^{\circ}\text{C}$

DC SPECIFICATIONS

Symbol	Parameter	Test Condition				Value						Unit	
		V _I (V)	V _O (V)	I _{oI} (μA)	V _{DD} (V)	T _A = 25°C			-40 to 85°C		-55 to 125°C		
						Min.	Typ.	Max.	Min.	Max.	Min.		Max.
I _L	Quiescent Current	0/5			5		0.02	1		30		30	μA
		0/10			10		0.02	2		60		60	
		0/15			15		0.02	4		120		120	
		0/20			20		0.04	20		600		600	
V _{OH}	High Level Output Voltage	0/5		<1	5	4.95			4.95		4.95		V
		0/10		<1	10	9.95			9.95		9.95		
		0/15		<1	15	14.95			14.95		14.95		
V _{OL}	Low Level Output Voltage	5/0		<1	5		0.05			0.05		0.05	V
		10/0		<1	10		0.05			0.05		0.05	
		15/0		<1	15		0.05			0.05		0.05	
V _P	Positive Trigger Threshold Voltage				5	2.2	2.9	3.6	2.2	3.6	2.2	3.6	V
					10	4.6	5.9	7.1	4.6	7.1	4.6	7.1	
					15	6.8	8.8	10.8	6.8	10.8	6.8	10.8	
V _N	Negative Trigger Threshold Voltage				5	0.9	1.9	2.8	0.9	2.8	0.9	2.8	V
					10	2.5	3.9	5.2	2.5	5.2	2.5	5.2	
					15	4	5.8	7.4	4	7.4	4	7.4	
V _H	Hysteresis Voltage				5	0.3	0.9	1.6	0.3	1.6	0.3	1.6	V
					10	1.2	2.3	3.4	1.2	3.4	1.2	3.4	
					15	1.6	3.5	5	1.6	5	1.6	5	
I _{OH}	Output Drive Current	0/5	2.5	<1	5	-1.36	-3.2		-1.15		-1.1		mA
		0/5	4.6	<1	5	-0.44	-1		-0.36		-0.36		
		0/10	9.5	<1	10	-1.1	-2.6		-0.9		-0.9		
		0/15	13.5	<1	15	-3.0	-6.8		-2.4		-2.4		
I _{OL}	Output Sink Current	0/5	0.4	<1	5	0.44	1		0.36		0.36		mA
		0/10	0.5	<1	10	1.1	2.6		0.9		0.9		
		0/15	1.5	<1	15	3.0	6.8		2.4		2.4		
I _I	Input Leakage Current	0/18	Any Input		18		±10 ⁻⁵	±0.1		±1		±1	μA
C _I	Input Capacitance		Any Input				5	7.5					pF

The Noise Margin for both "1" and "0" level is: 1V min. with V_{DD}=5V, 2V min. with V_{DD}=10V, 2.5V min. with V_{DD}=15V

DYNAMIC ELECTRICAL CHARACTERISTICS (T_{amb} = 25°C, C_L = 50pF, R_L = 200KΩ, t_r = t_f = 20 ns)

Symbol	Parameter	Test Condition		Value (*)			Unit
		V _{DD} (V)		Min.	Typ.	Max.	
t _{PLH} t _{PHL}	Propagation Delay Time	5			140	280	ns
		10			70	140	
		15			60	120	
t _{TLH} t _{THL}	Output Transition Time	5			100	200	ns
		10			50	100	
		15			40	80	

(*) Typical temperature coefficient for all V_{DD} value is 0.3 %/°C.

TYPICAL APPLICATIONS

ASTABLE MULTIVIBRATOR

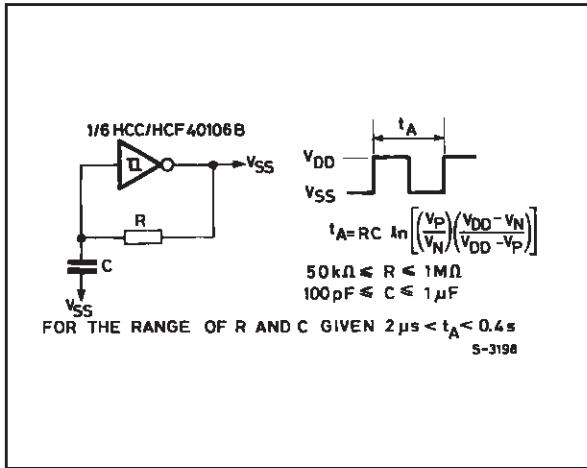

MONOSTABLE MULTIVIBRATOR

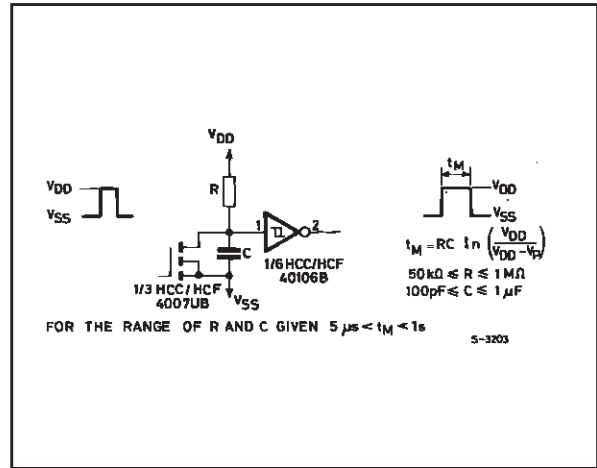

WAVE SHAPER

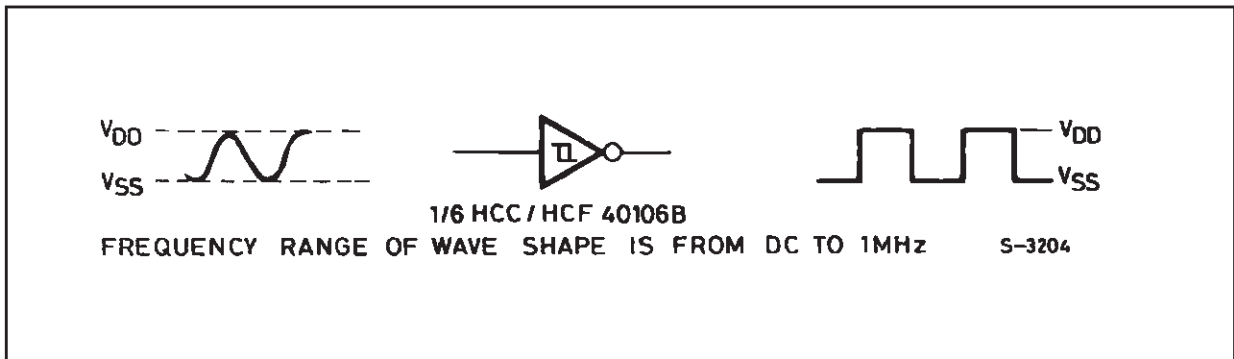

TEST CIRCUIT

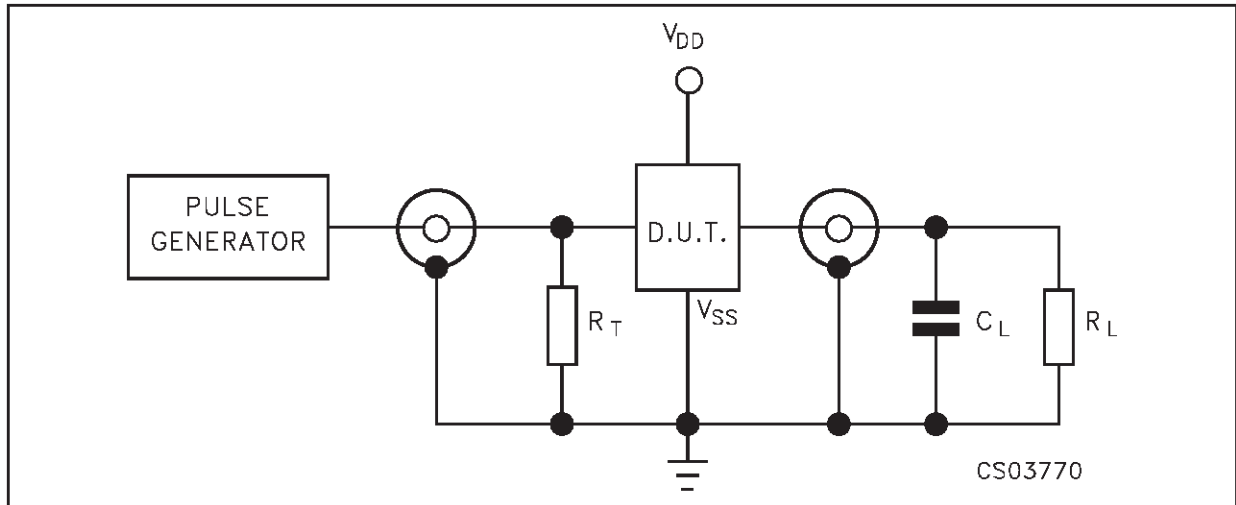

$C_L = 50\text{pF}$ or equivalent (includes jig and probe capacitance)
 $R_L = 200\text{K}\Omega$
 $R_T = Z_{\text{OUT}}$ of pulse generator (typically 50Ω)

WAVEFORM : PROPAGATION DELAY TIMES ($f=1\text{MHz}$; 50% duty cycle)

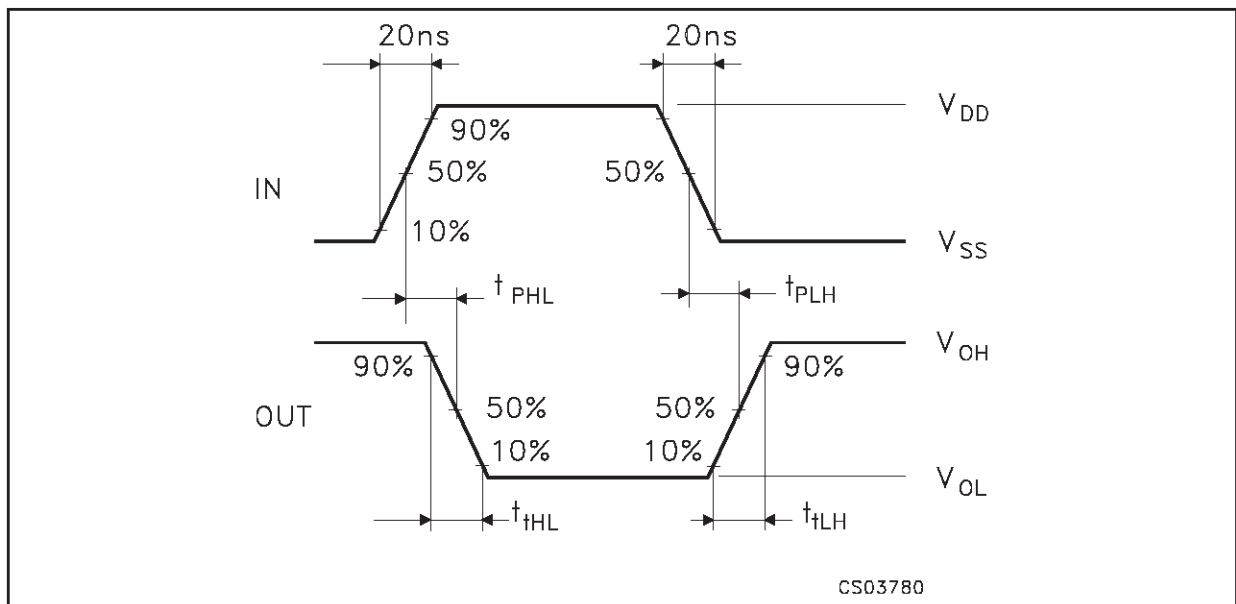

Plastic DIP-14 MECHANICAL DATA						
---------------------------------------	--	--	--	--	--	--

DIM.	mm.			inch		
	MIN.	TYP	MAX.	MIN.	TYP.	MAX.
a1	0.51			0.020		
B	1.39		1.65	0.055		0.065
b		0.5			0.020	
b1		0.25			0.010	
D			20			0.787
E		8.5			0.335	
e		2.54			0.100	
e3		15.24			0.600	
F			7.1			0.280
I			5.1			0.201
L		3.3			0.130	
Z	1.27		2.54	0.050		0.100

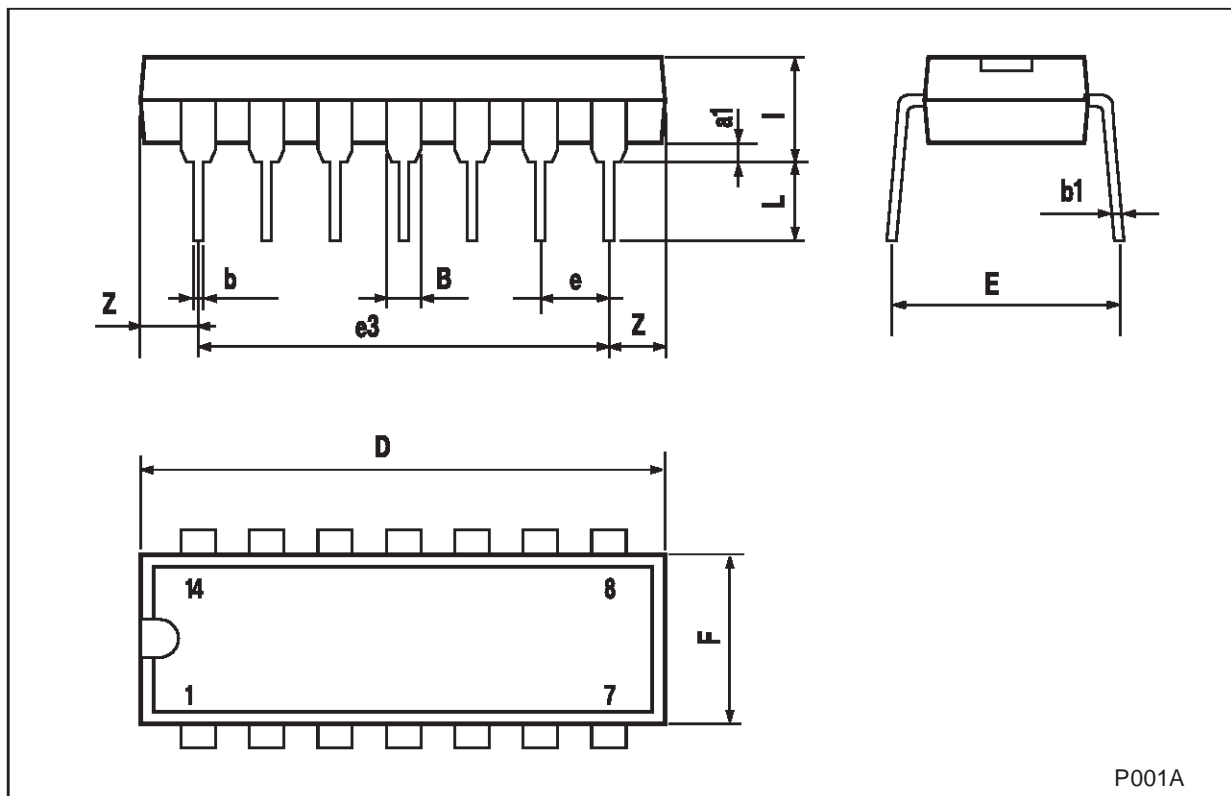

SO-14 MECHANICAL DATA

DIM.	mm.			inch		
	MIN.	TYP.	MAX.	MIN.	TYP.	MAX.
A			1.75			0.068
a1	0.1		0.2	0.003		0.007
a2			1.65			0.064
b	0.35		0.46	0.013		0.018
b1	0.19		0.25	0.007		0.010
C		0.5			0.019	
c1	45° (typ.)					
D	8.55		8.75	0.336		0.344
E	5.8		6.2	0.228		0.244
e		1.27			0.050	
e3		7.62			0.300	
F	3.8		4.0	0.149		0.157
G	4.6		5.3	0.181		0.208
L	0.5		1.27	0.019		0.050
M			0.68			0.026
S	8° (max.)					

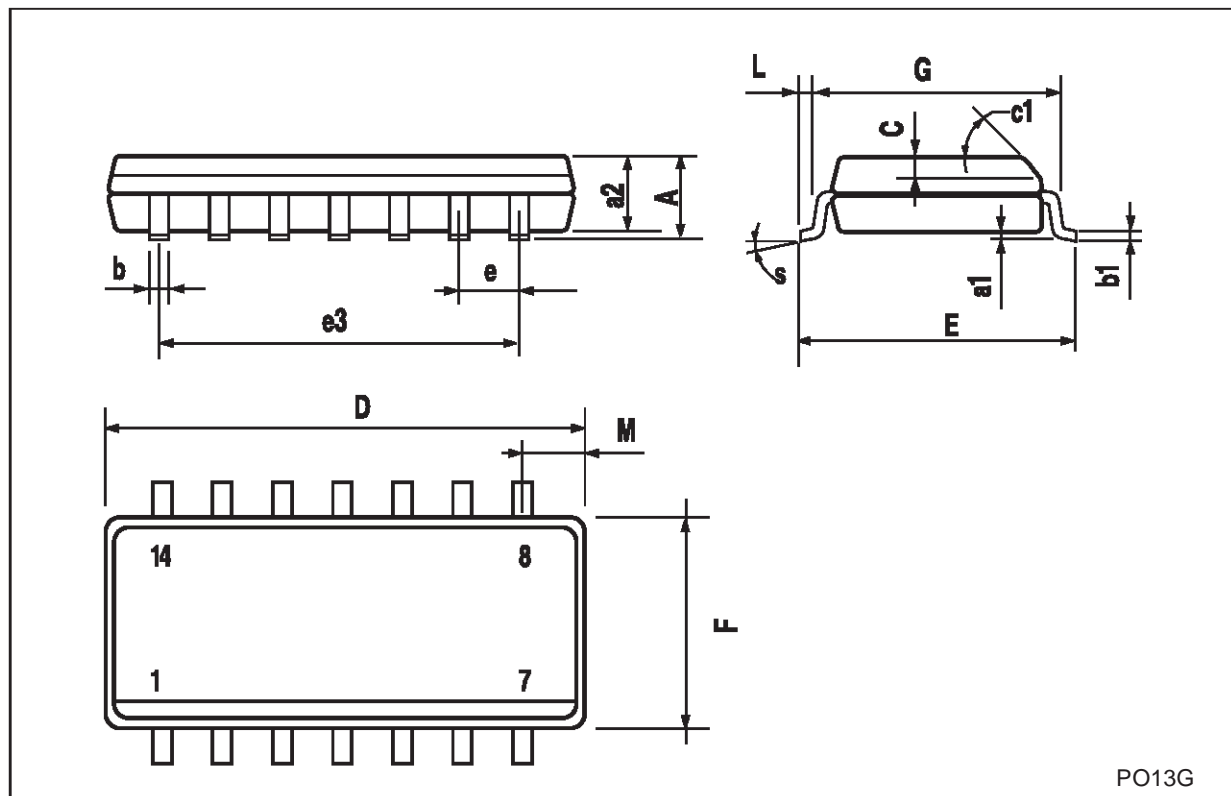

PO13G

Information furnished is believed to be accurate and reliable. However, STMicroelectronics assumes no responsibility for the consequences of use of such information nor for any infringement of patents or other rights of third parties which may result from its use. No license is granted by implication or otherwise under any patent or patent rights of STMicroelectronics. Specifications mentioned in this publication are subject to change without notice. This publication supersedes and replaces all information previously supplied. STMicroelectronics products are not authorized for use as critical components in life support devices or systems without express written approval of STMicroelectronics.

© The ST logo is a registered trademark of STMicroelectronics

© 2001 STMicroelectronics - Printed in Italy - All Rights Reserved
STMicroelectronics GROUP OF COMPANIES

Australia - Brazil - China - Finland - France - Germany - Hong Kong - India - Italy - Japan - Malaysia - Malta - Morocco
Singapore - Spain - Sweden - Switzerland - United Kingdom

© <http://www.st.com>

