

FAN6961

Critical Conduction Mode PFC Controller

Features

- Boundary Mode PFC Controller
- Low Input Current THD
- Controlled On-Time PWM
- Zero-Current Detection
- Cycle-by-Cycle Current Limiting
- Leading-Edge Blanking instead of RC Filtering
- Low Start-up Current: 10µA Typical
- Low Operating Current: 4.5mA Typical
- Feedback Open-Loop Protection
- Programmable Maximum On-Time (MOT)
- Output Over-Voltage Clamping Protection
- Clamped Gate Output Voltage 16.5V

Description

The FAN6961 is an 8-pin, boundary-mode, PFC controller IC intended for controlling PFC pre-regulators. The FAN6961 provides a controlled on-time to regulate the output DC voltage and achieve natural power factor correction. The maximum on-time of the external switch is programmable to ensure safe operation during AC brownouts. An innovative multi-vector error amplifier is built in to provide rapid transient response and precise output voltage clamping. A built-in circuit disables the controller if the output feedback loop is opened. The start-up current is lower than 20µA and the operating current has been reduced to under 6mA. The supply voltage can be up to 25V, maximizing application flexibility.

Applications

- Electric Lamp Ballasts
- AC-DC Switching Mode Power Converter
- Open Frame Power Supplies and Power Adapters
- Flyback Power Converters with ZCS / ZVS

Ordering Information

Part Number	Operating Temperature Range	Package	 Eco Status	Packing Method
FAN6961SZ	-40°C to +125°C	8-Pin, Small Outline Package (SOP)	RoHS	Tape & Reel
FAN6961DZ	-40°C to +125°C	8-Pin, Dual In-line Package (DIP)	RoHS	Tube

 For Fairchild's definition of "green" Eco Status, please visit: http://www.fairchildsemi.com/company/green/rohs_green.html.

Marking Information

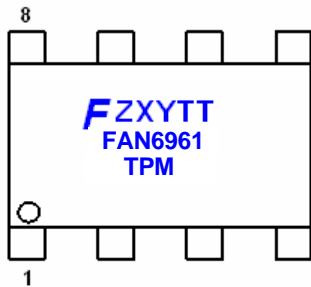

F- Fairchild logo
Z- Plant Code
X- 1 digit year code
Y- 1 digit week code
TT: 2 digits die run code
T: Package type (S=SOP, D=DIP)
P: Z: Pb free
M: Manufacture flow code

Figure 3. Marking Information

Pin Configuration

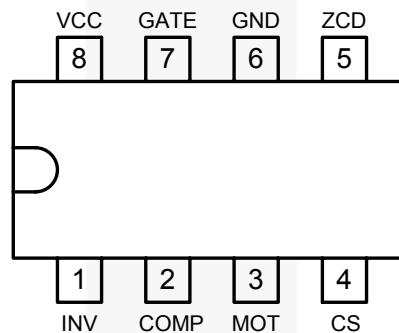

Figure 4. DIP and SOP Pin Configuration (Top View)

Pin Definitions

Pin #	Name	Description
1	INV	Inverting input of the error amplifier. INV is connected to the converter output via a resistive divider. This pin is also used for over-voltage clamping and open-loop feedback protection.
2	COMP	The output of the error amplifier. To create a precise clamping protection, a compensation network between this pin and GND is suggested.
3	MOT	Maximum On Time A resistor from MOT to GND is used to determine the maximum on-time of the external power MOSFET. The maximum output power of the converter is a function of the maximum on time.
4	CS	Current Sense. Input to the over-current protection comparator. When the sensed voltage across the sense resistor reaches the internal threshold (0.8V), the switch is turned off to activate cycle-by-cycle current limiting.
5	ZCD	Zero Current Detection. This pin is connected to an auxiliary winding via a resistor to detect the zero crossing of the switch current. When the zero crossing is detected, a new switching cycle is started. If it is connected to GND, the device is disabled.
6	GND	Ground. The power ground and signal ground. Placing a 0.1µF decoupling capacitor between VCC and GND is recommended.
7	GATE	Driver output. Totem-pole driver output to drive the external power MOSFET. The clamped gate output voltage is 16.5V.
8	VCC	Power supply. Driver and control circuit supply voltage.

Absolute Maximum Ratings

Stresses exceeding the absolute maximum ratings may damage the device. The device may not function or be operable above the recommended operating conditions and stressing the parts to these levels is not recommended. In addition, extended exposure to stresses above the recommended operating conditions may affect device reliability. The absolute maximum ratings are stress ratings only. All voltage values, except differential voltage, are given with respect to GND pin.

Symbol	Parameter	Min.	Max.	Unit
V _{VCC}	DC Supply Voltage		30	V
V _{HIGH}	Gate Driver	-0.3	30.0	V
V _{LOW}	Others (INV, COMP, MOT, CS)	-0.3	7.0	V
V _{ZCD}	Input Voltage to ZCD Pin	-0.3	12.0	V
P _D	Power Dissipation	SOP	400	mW
		DIP	800	
T _J	Operating Junction Temperature	-40	+125	°C
θ _{JA}	Thermal Resistance (Junction-to-Air)	SOP	150	°C/W
		DIP	113	
T _{STG}	Storage Temperature Range	-65	+150	°C
T _L	Lead Temperature (Wave Soldering or IR, 10 Seconds)	SOP	+230	°C
		DIP	+260	
ESD	Electrostatic Discharge Capability, Human Body Model		2.5	KV
	Electrostatic Discharge Capability, Machine Model		200	V

Recommended Operating Conditions

The Recommended Operating Conditions table defines the conditions for actual device operation. Recommended operating conditions are specified to ensure optimal performance to the datasheet specifications. Fairchild does not recommend exceeding them or designing to Absolute Maximum Ratings.

Symbol	Parameter	Min.	Typ.	Max.	Unit
T _A	Operating Ambient Temperature	-40		+125	°C

Electrical Characteristics

$V_{CC}=15V$ and $T_A=25^{\circ}C$ unless otherwise noted.

Symbol	Parameter	Conditions	Min.	Typ.	Max.	Units
V_{CC} Section						
V _{CC-OP}	Continuous Operation Voltage				24.5	V
V _{CC-ON}	Turn-on Threshold Voltage		11	12	13	V
V _{CC-OFF}	Turn-off Threshold Voltage		8.5	9.5	10.5	V
I _{CC-ST}	Start-up Current	$V_{CC}=V_{CC-ON} - 0.16V$		10	20	μA
I _{CC-OP}	Operating Supply Current	$V_{CC}=12V, V_{CS}=0V,$ $C_L=3nF, f_{SW}=60KHz$		4.5	6	mA
V _{CC-OVP}	V _{DD} Over-Voltage Protection Level		26.5	27.5	28.5	V
t _{D-VCCOVP}	V _{DD} Over-Voltage Protection Debounce			30		μs
Error Amplifier Section						
V _{REF}	Reference Voltage		2.475	2.500	2.525	V
G _m	Transconductance			125		μmho
V _{INVH}	Clamp High Feedback Voltage			2.65	2.70	V
V _{INVL}	Clamp Low Feedback Voltage		2.25	2.30		V
V _{OUT HIGH}	Output High Voltage		4.8			V
V _{oZ}	Zero Duty Cycle Output Voltage		1.15	1.25	1.35	V
V _{INV-OVP}	Over Voltage Protection for INV Input		2.70	2.75	2.80	V
V _{INV-UVP}	Under Voltage Protection for INV Input		0.40	0.45	0.50	V
I _{COMP}	Source Current	$V_{INV}=2.35V, V_{COMP}=1.5V$	10	20		μA
		$V_{INV}=1.5V,$	550	800		
	Sink Current	$V_{INV}=2.65V, V_{COMP}=5V$	10	20		
Current-Sense Section						
V _{PK}	Threshold Voltage for Peak Current Limit Cycle-by-Cycle Limit		0.77	0.82	0.87	V
t _{PD}	Propagation Delay				200	ns
t _{LEB}	Leading-Edge Blanking Time	$R_{MOT}=24k\Omega, V_{COMP}=5V$		400	500	ns
		$R_{MOT}=24k\Omega,$ $V_{COMP}=V_{oZ}+50mV$		270	350	
Gate Section						
V _{Z-OUT}	Output Voltage Maximum (Clamp)	$V_{CC}=25V$	15.0	16.5	18.0	V
V _{OL}	Output Voltage Low	$V_{CC}=15V, I_O=100mA$			1.4	V
V _{OH}	Output Voltage High	$V_{CC}=14V, I_O=100mA$	8			V
t _R	Rising Time	$V_{CC}=12V, C_L=3nF,$ 20~80%		80		ns
t _F	Falling Time	$V_{CC}=12V, C_L=3nF,$ 80~20%		40		ns

Continued on the following page...

Electrical Characteristics

$V_{CC}=15V$ and $T_A=25^{\circ}C$ unless otherwise noted.

Symbol	Parameter	Conditions	Min.	Typ.	Max.	Units
Zero Current Detection Section						
V_{ZCD}	Input Threshold Voltage Rising Edge	V_{ZCD} Increasing	1.9	2.1	2.3	V
H_{YS} of V_{ZCD}	Threshold Voltage Hysteresis	V_{ZCD} Decreasing		0.35		V
$V_{ZCD-HIGH}$	Upper Clamp Voltage	$I_{ZCD}=3mA$			12	V
$V_{ZCD-LOW}$	Lower Clamp Voltage	$I_{ZCD}=-1.5mA$	0.3			V
t_{DEAD}	Maximum Delay, ZCD to Output Turn-On	$V_{COMP}=5V$, $f_{SW}=60KHz$	100		400	ns
$t_{RESTART}$	Restart Time	Output Turned Off by ZCD	300	500	700	μs
t_{INHIB}	Inhibit Time (Maximum Switching Frequency Limit)	$R_{MOT}=24k\Omega$		2.8		μs
V_{DIS}	Disable Threshold Voltage		150	200	250	mV
$t_{ZCD-DIS}$	Disable Function Debounce Time	$R_{MOT}=24k\Omega$, $V_{ZCD}=100mV$	800			μs
Maximum On Time Section						
V_{MOT}	Maximum On Time Voltage		1.25	1.30	1.35	V
t_{ON-MAX}	Maximum On Time Programming (Resistor Based)	$R_{MOT}=24k\Omega$, $V_{CS}=0V$, $V_{COMP}=5V$		25		μs

Typical Performance Characteristics

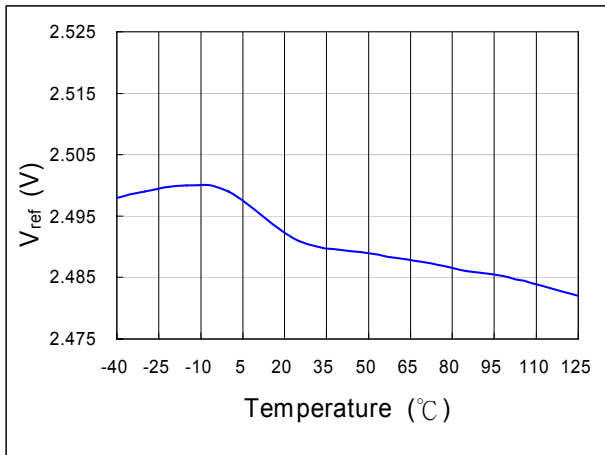

Figure 5. V_{ref} vs. T_A

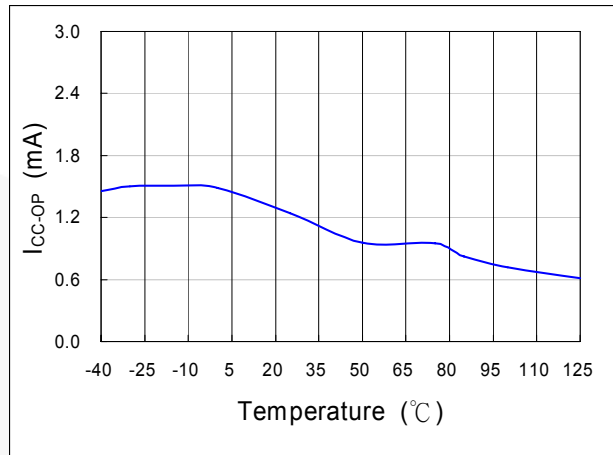

Figure 6. I_{CC-OP} vs. T_A

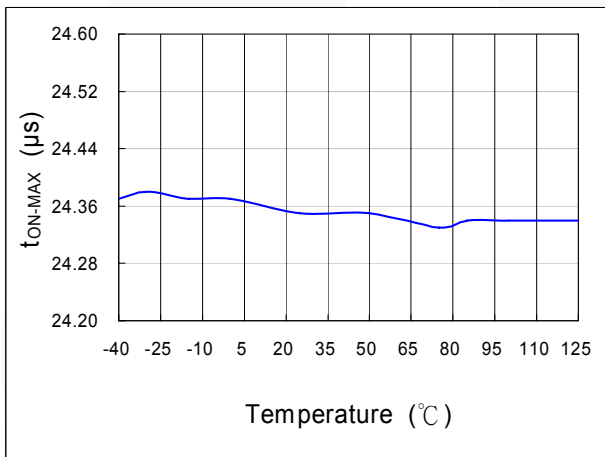

Figure 7. t_{ON-MAX} vs. T_A

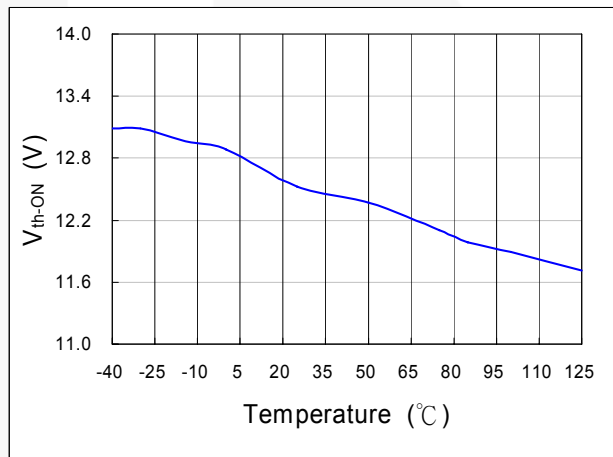

Figure 8. V_{th-ON} vs. T_A

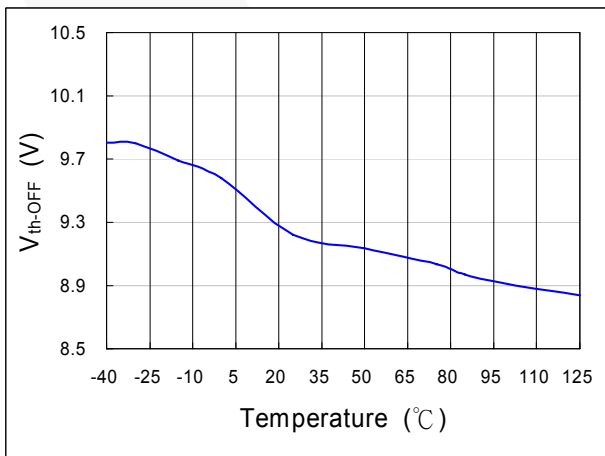

Figure 9. V_{th-OFF} vs. T_A

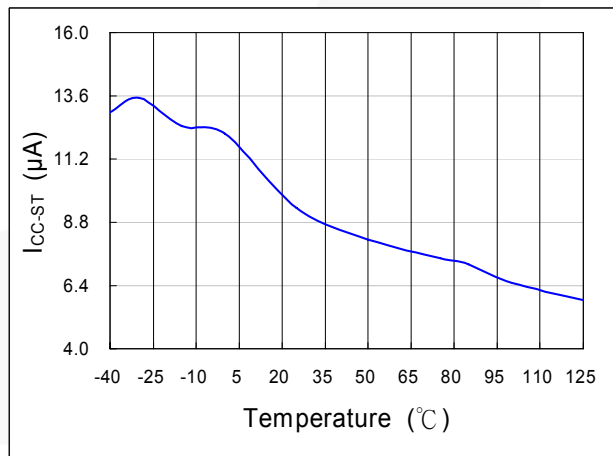

Figure 10. I_{CC-ST} vs. T_A

Typical Performance Characteristics (Continued)

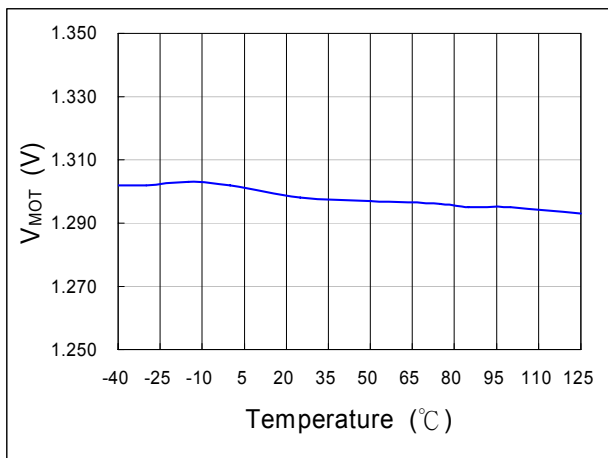

Figure 11. V_{MOT} vs. T_A

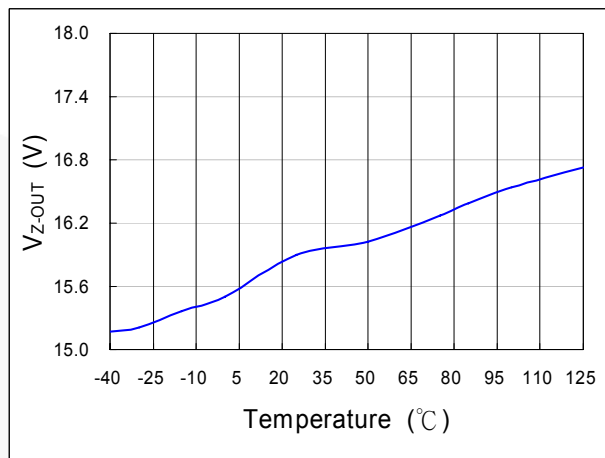

Figure 12. V_{Z-OUT} vs. T_A

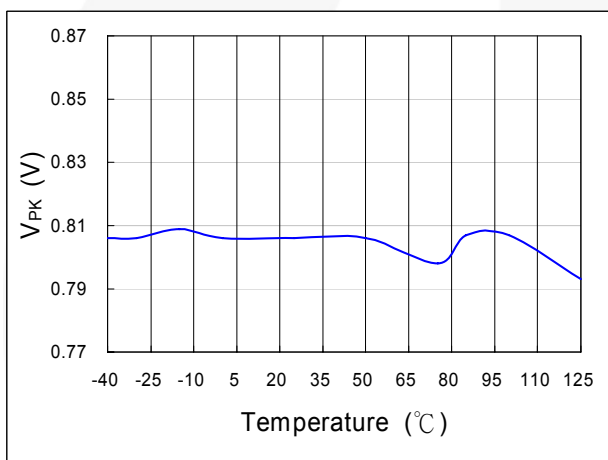

Figure 13. V_{PK} vs. T_A

Functional Description

Error Amplifier

The inverting input of the error amplifier is referenced to INV. The output of the error amplifier is referenced to COMP. The non-inverting input is internally connected to a fixed $2.5V \pm 2\%$ voltage. The output of the error amplifier is used to determine the on-time of the PWM output and regulate the output voltage. To achieve a low input current THD, the variation of the on time within one input AC cycle should be very small. A multi-vector error amplifier is built in to provide fast transient response and precise output voltage clamping.

For FAN6961, connecting a capacitance, such as $1\mu F$, between COMP and GND is suggested. The error amplifier is a trans-conductance amplifier that converts voltage to current with a $125\mu mho$.

Start-Up Current

Typical start-up current is less than $20\mu A$. This ultra-low start-up current allows the usage of high resistance, low-wattage start-up resistor. For example, $1M\Omega/0.25W$ start-up resistor and a $10\mu F/25V$ (V_{CC} hold-up) capacitor are recommended for an AC-to-DC power adaptor with a wide input range $85-265V_{AC}$.

Operating Current

Operating current is typically $4.5mA$. The low operating current enables a better efficiency and reduces the requirement of V_{CC} hold-up capacitance.

Maximum On-Time Operation

Given a fixed inductor value and maximum output power, the relationship between on-time and line voltage is:

$$t_{on} = \frac{2 \cdot L \cdot P_o}{V_{rms}^2 \cdot \eta} \quad (1)$$

If the line voltage is too low or the inductor value is too high, t_{ON} is too long. To avoid extra low operating frequency and achieve brownout protection, the maximum value of t_{ON} is programmable by one resistor, R_I , connected between MOT and GND. A $24k\Omega$ resistor R_I generates corresponds to $25\mu s$ maximum on time:

$$t_{on(max)} = R_I(k\Omega) \cdot \frac{25}{24}(\mu s) \quad (2)$$

The range of the maximum on-time is designed as $10 \sim 50\mu s$.

Peak Current Limiting

The switch current is sensed by one resistor. The signal is feed into CS pin and an input terminal of a comparator. A high voltage in CS pin terminates a switching cycle immediately and cycle-by-cycle current limit is achieved. The designed threshold of the protection point is $0.82V$.

Leading-Edge Blanking (LEB)

A turn-on spike on CS pin appears when the power MOSFET is switched on. At the beginning of each switching pulse, the current-limit comparator is disabled for around $400ns$ to avoid premature termination. The gate drive output cannot be switched off during the blanking period. Conventional RC filtering is not necessary, so the propagation delay of current limit protection can be minimized.

Under-Voltage Lockout (UVLO)

The turn-on and turn-off threshold voltage is fixed internally at $12V/9.5V$. This hysteresis behavior guarantees a one-shot start-up with proper start-up resistor and hold-up capacitor. With an ultra-low start-up current of $20\mu A$, one $1M\Omega R_{IN}$ is sufficient for start-up under low input line voltage, $85V_{rms}$. Power dissipation on R_{IN} would be less than $0.1W$ even under high line ($V_{AC}=265V_{rms}$) condition.

Output Driver

With low on resistance and high current driving capability, the output driver can drive an external capacitive load larger than $3000pF$. Cross conduction current has been avoided to minimize heat dissipation, improving efficiency and reliability. This output driver is internally clamped by a $16.5V$ Zener diode.

Zero-Current Detection (ZCD)

The zero-current detection of the inductor is achieved using its auxiliary winding. When the stored energy of the inductor is fully released to output, the voltage on ZCD goes down and a new switching cycle is enabled after a ZCD trigger. The power MOSFET is always turned on with zero inductor current such that turn-on loss and noise can be minimized. The converter works in boundary mode and peak inductor current is always exactly twice of the average current. A natural power factor correction function is achieved with the low-bandwidth, on-time modulation. An inherent maximum off time is built in to ensure proper start-up operation. This ZCD pin can be used as a synchronous input.

Noise Immunity

Noise on the current sense or control signal can cause significant pulse-width jitter, particularly in the boundary-mode operation. Slope compensation and built-in debounce circuit can alleviate this problem. Because the FAN6961 has a single ground pin, high sink current at the output cannot be returned separately. Good high-frequency or RF layout practices should be followed. Avoiding long PCB traces and component leads, locating compensation and filter components near to the FAN6961, and increasing the power MOSFET gate resistance improve performance.

Reference Circuit

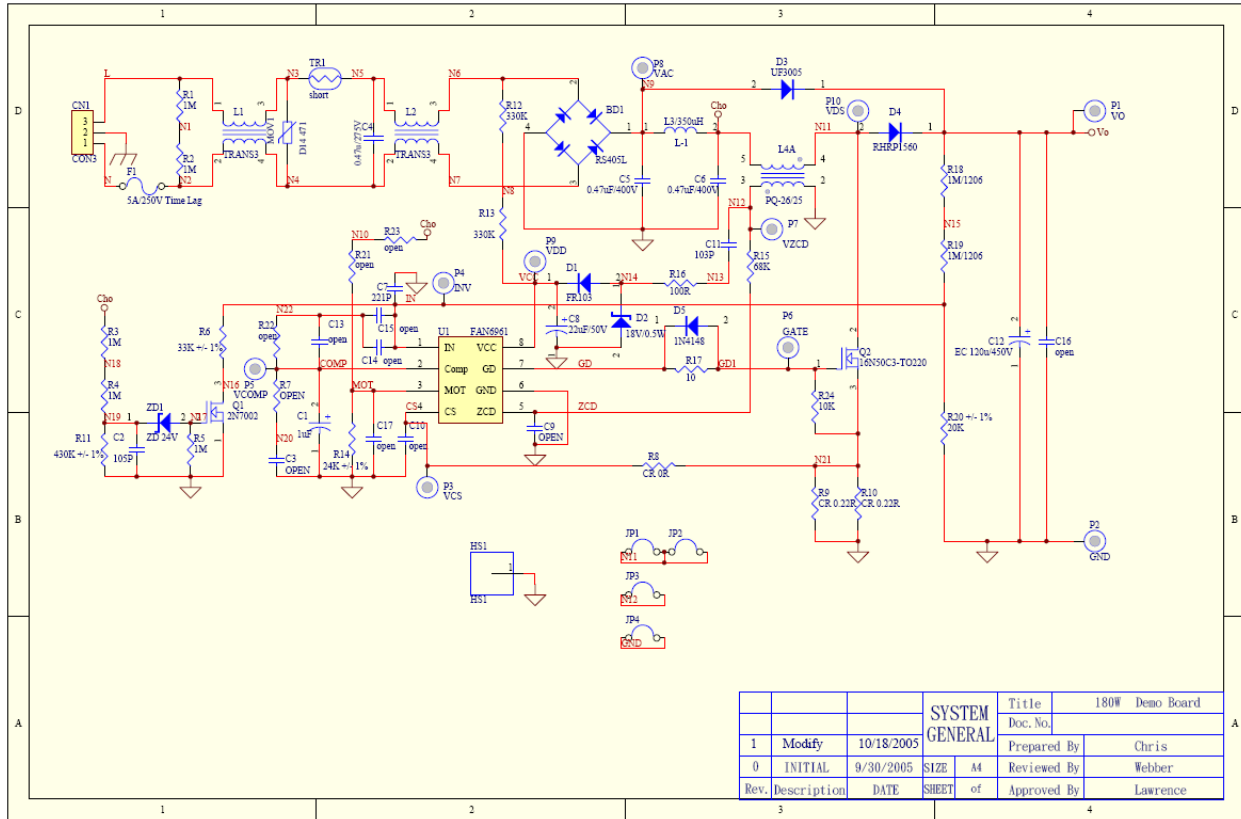
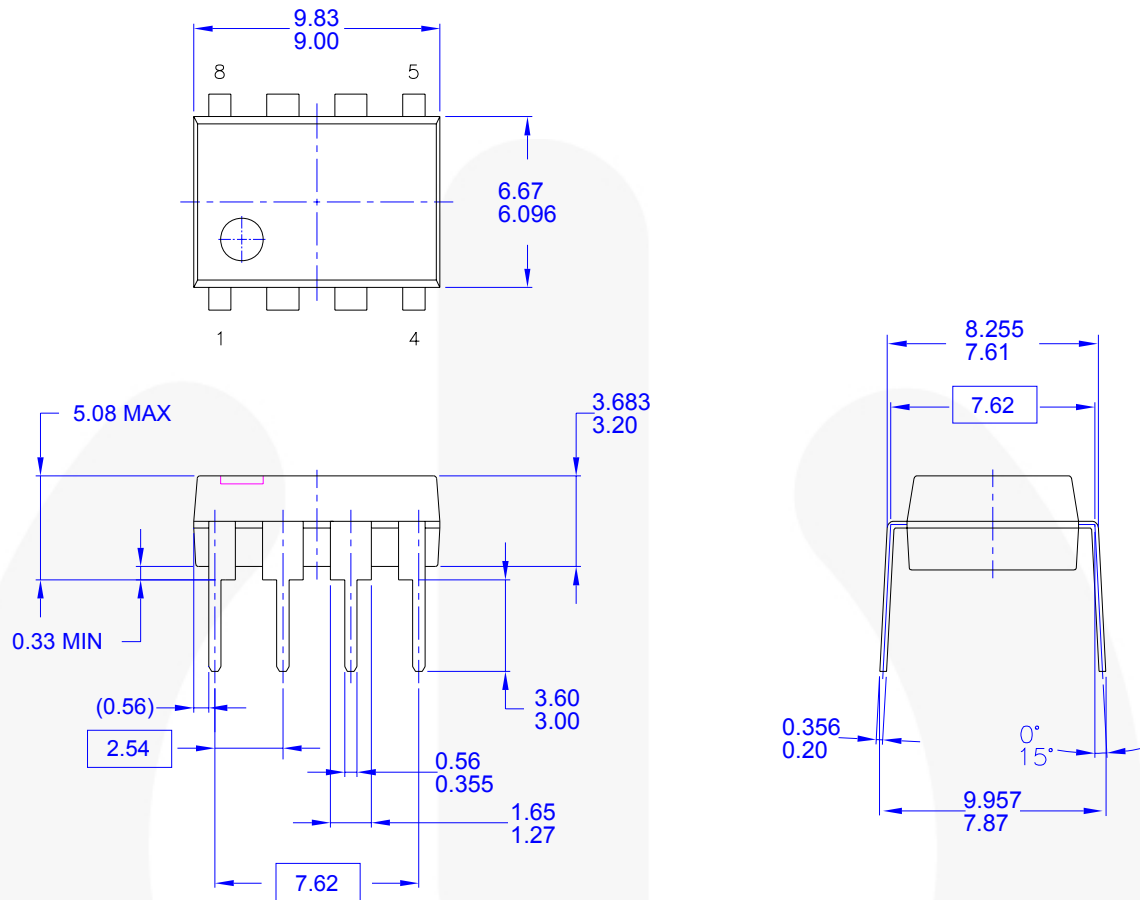

Figure 14. Reference Circuit

Mechanical Dimensions



- NOTES: UNLESS OTHERWISE SPECIFIED**
- A) THIS PACKAGE CONFORMS TO JEDEC MS-001 VARIATION BA
 - B) ALL DIMENSIONS ARE IN MILLIMETERS.
 - C) DIMENSIONS ARE EXCLUSIVE OF BURRS, MOLD FLASH, AND TIE BAR EXTRUSIONS.
 - D) DIMENSIONS AND TOLERANCES PER ASME Y14.5M-1994
 - E) DRAWING FILENAME AND REVISION: MKT-N08FREV2.

Figure 15. 8-Lead, PDIP, JEDEC MS-001, .300" Wide

Package drawings are provided as a service to customers considering Fairchild components. Drawings may change in any manner without notice. Please note the revision and/or date on the drawing and contact a Fairchild Semiconductor representative to verify or obtain the most recent revision. Package specifications do not expand the terms of Fairchild's worldwide terms and conditions, specifically the warranty therein, which covers Fairchild products.

Always visit Fairchild Semiconductor's online packaging area for the most recent package drawings:
<http://www.fairchildsemi.com/packaging/>.

Mechanical Dimensions (Continued)

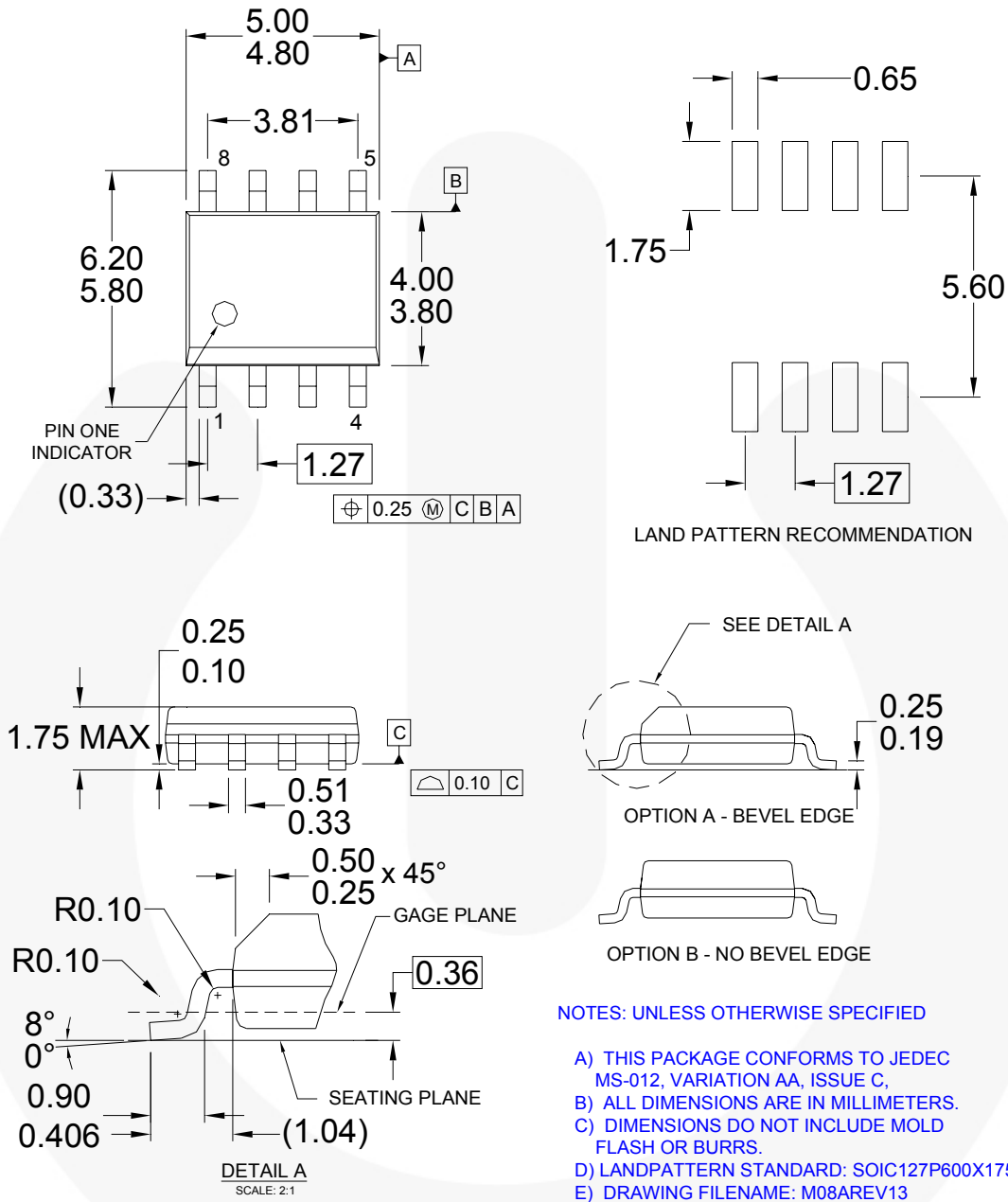







Figure 16. 8-Lead, SOIC, JEDEC MS-012, .150" Narrow Body

Package drawings are provided as a service to customers considering Fairchild components. Drawings may change in any manner without notice. Please note the revision and/or date on the drawing and contact a Fairchild Semiconductor representative to verify or obtain the most recent revision. Package specifications do not expand the terms of Fairchild's worldwide terms and conditions, specifically the warranty therein, which covers Fairchild products.

Always visit Fairchild Semiconductor's online packaging area for the most recent package drawings:
<http://www.fairchildsemi.com/packaging/>.

TRADEMARKS

The following are registered and unregistered trademarks Fairchild Semiconductor owns or is authorized to use and is not intended to be an exhaustive list of all such trademarks.

Build it Now™	FPST™	PDP SPM™	The Power Franchise®
CorePLUS™	F-PFST™	Power-SPM™	
CorePOWER™	FRFET®	PowerTrench®	TinyBoost™
CROSSVOLT™	Global Power Resource™	Programmable Active Droop™	TinyBuck™
CTL™	Green FPS™	QFET®	TinyLogic®
Current Transfer Logic™	Green FPS™ e-Series™	QST™	TINYOPTO™
EcoSPARK®	GTO™	Quiet Series™	TinyPower™
EfficientMax™	IntelliMAX™	RapidConfigure™	TinyPWM™
EZSWITCH™ *	ISOPLANAR™	Saving our world, 1mW at a time™	TinyWire™
	MegaBuck™	SmartMax™	μSerDes™
	MICROCOUPLER™	SMART START™	
Fairchild®	MicroFET™	SPM®	UHC®
Fairchild Semiconductor®	MicroPak™	STEALTH™	Ultra FRFET™
FACT Quiet Series™	MillerDrive™	SuperFET™	UniFET™
FACT®	MotionMax™	SuperSOT™-3	VCX™
FAST®	Motion-SPM™	SuperSOT™-6	VisualMax™
FastvCore™	OPTOLOGIC®	SuperSOT™-8	
FlashWriter®*	OPTOPLANAR®	SupreMOS™	
		SyncFET™	
			

* EZSWITCH™ and FlashWriter® are trademarks of System General Corporation, used under license by Fairchild Semiconductor.

WARNING AND DISCLAIMER

Replace components on the Evaluation Board only with those parts shown on the parts list (or Bill of Materials) in the Users' Guide. Contact an authorized Fairchild representative with any questions.

The Evaluation board (or kit) is for demonstration purposes only and neither the Board nor this User's Guide constitute a sales contract or create any kind of warranty, whether express or implied, as to the applications or products involved. Fairchild warrants that its products meet Fairchild's published specifications, but does not guarantee that its products work in any specific application. Fairchild reserves the right to make changes without notice to any products described herein to improve reliability, function, or design. Either the applicable sales contract signed by Fairchild and Buyer or, if no contract exists, Fairchild's standard Terms and Conditions on the back of Fairchild invoices, govern the terms of sale of the products described herein.

DISCLAIMER

FAIRCHILD SEMICONDUCTOR RESERVES THE RIGHT TO MAKE CHANGES WITHOUT FURTHER NOTICE TO ANY PRODUCTS HEREIN TO IMPROVE RELIABILITY, FUNCTION, OR DESIGN. FAIRCHILD DOES NOT ASSUME ANY LIABILITY ARISING OUT OF THE APPLICATION OR USE OF ANY PRODUCT OR CIRCUIT DESCRIBED HEREIN; NEITHER DOES IT CONVEY ANY LICENSE UNDER ITS PATENT RIGHTS, NOR THE RIGHTS OF OTHERS.

LIFE SUPPORT POLICY

FAIRCHILD'S PRODUCTS ARE NOT AUTHORIZED FOR USE AS CRITICAL COMPONENTS IN LIFE SUPPORT DEVICES OR SYSTEMS WITHOUT THE EXPRESS WRITTEN APPROVAL OF THE PRESIDENT OF FAIRCHILD SEMICONDUCTOR CORPORATION.

As used herein:

1. Life support devices or systems are devices or systems which, (a) are intended for surgical implant into the body, or (b) support or sustain life, or (c) whose failure to perform when properly used in accordance with instructions for use provided in the labeling, can be reasonably expected to result in significant injury to the user.
2. A critical component is any component of a life support device or system whose failure to perform can be reasonably expected to cause the failure of the life support device or system, or to affect its safety or effectiveness.

ANTI-COUNTERFEITING POLICY

Fairchild Semiconductor Corporation's Anti-Counterfeiting Policy. Fairchild's Anti-Counterfeiting Policy is also stated on our external website, www.fairchildsemi.com, under Sales Support.

Counterfeiting of semiconductor parts is a growing problem in the industry. All manufacturers of semiconductor products are experiencing counterfeiting of their parts. Customers who inadvertently purchase counterfeit parts experience many problems such as loss of brand reputation, substandard performance, failed applications, and increased cost of production and manufacturing delays. Fairchild is taking strong measures to protect ourselves and our customers from the proliferation of counterfeit parts. Fairchild strongly encourages customers to purchase Fairchild parts either directly from Fairchild or from Authorized Fairchild Distributors who are listed by country on our web page cited above. Products customers buy either from Fairchild directly or from Authorized Fairchild Distributors are genuine parts, have full traceability, meet Fairchild's quality standards for handling and storage and provide access to Fairchild's full range of up-to-date technical and product information. Fairchild and our Authorized Distributors will stand behind all warranties and will appropriately address any warranty issues that may arise. Fairchild will not provide any warranty coverage or other assistance for parts bought from Unauthorized Sources. Fairchild is committed to combat this global problem and encourage our customers to do their part in stopping this practice by buying direct or from authorized distributors.