

13A, 50V, 0.120 Ohm, N-Channel Power MOSFET

This is an N-Channel enhancement mode silicon gate power field effect transistor designed for applications such as switching regulators, switching converters, motor drivers, relay drivers, and drivers for high power bipolar switching transistors requiring high speed and low gate drive power. This type can be operated directly from integrated circuits.

Formerly developmental type TA9770.

Ordering Information

| PART NUMBER | PACKAGE | BRAND |
|-------------|----------|--------|
| BUZ71A | TO-220AB | BUZ71A |

NOTE: When ordering, use the entire part number.

Features

- 13A, 50V
- $r_{DS(ON)} = 0.120\Omega$
- SOA is Power Dissipation Limited
- Nanosecond Switching Speeds
- Linear Transfer Characteristics
- High Input Impedance
- Majority Carrier Device
- Related Literature
 - TB334 "Guidelines for Soldering Surface Mount Components to PC Boards"

Symbol

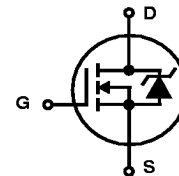

Packaging

JEDEC TO-220AB

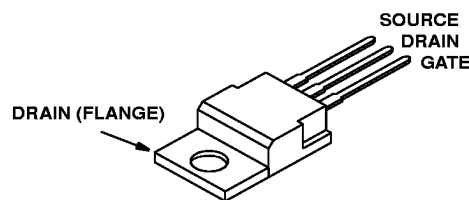

BUZ71A

Absolute Maximum Ratings $T_C = 25^\circ\text{C}$, Unless Otherwise Specified

| | BUZ71A | UNITS |
|---|------------|---------------------|
| Drain to Source Breakdown Voltage (Note 1) | 50 | V |
| Drain to Gate Voltage ($R_{GS} = 20k\Omega$) (Note 1) | 50 | V |
| Continuous Drain Current, $T_C = 55^\circ\text{C}$ | 13 | A |
| Pulsed Drain Current (Note 3) | 48 | A |
| Gate to Source Voltage | ± 20 | V |
| Maximum Power Dissipation | 40 | W |
| Single Pulse Avalanche Energy Rating (Note 4) | 100 | mJ |
| Linear Derating Factor | 0.32 | W/ $^\circ\text{C}$ |
| Operating and Storage Temperature | -55 to 150 | $^\circ\text{C}$ |
| DIN Humidity Category - DIN 40040 | E | |
| IEC Climatic Category - DIN IEC 68-1 | 55/150/56 | |
| Maximum Temperature for Soldering | | |
| Leads at 0.063in (1.6mm) from Case for 10s. | 300 | $^\circ\text{C}$ |
| Package Body for 10s, See Techbrief 334 | 260 | $^\circ\text{C}$ |

CAUTION: Stresses above those listed in "Absolute Maximum Ratings" may cause permanent damage to the device. This is a stress only rating and operation of the device at these or any other conditions above those indicated in the operational sections of this specification is not implied.

NOTE:

1. $T_J = 25^\circ\text{C}$ to 125°C .

Electrical Specifications $T_C = 25^\circ\text{C}$, Unless Otherwise Specified

| PARAMETER | SYMBOL | TEST CONDITIONS | MIN | TYP | MAX | UNITS |
|--|-----------------|---|------------|------|------|---------------------------|
| Drain to Source Breakdown Voltage | BV_{DSS} | $I_D = 250\mu\text{A}$, $V_{GS} = 0\text{V}$ | 50 | - | - | V |
| Gate to Threshold Voltage | $V_{GS(TH)}$ | $V_{GS} = V_{DS}$, $I_D = 1\text{mA}$ (Figure 9) | 2.1 | 3 | 4 | V |
| Zero Gate Voltage Drain Current | I_{DSS} | $T_J = 25^\circ\text{C}$, $V_{DS} = 50\text{V}$, $V_{GS} = 0\text{V}$ | - | 20 | 250 | μA |
| | | $T_J = 125^\circ\text{C}$, $V_{DS} = 50\text{V}$, $V_{GS} = 0\text{V}$ | - | 100 | 1000 | μA |
| Gate to Source Leakage Current | I_{GSS} | $V_{GS} = 20\text{V}$, $V_{DS} = 0\text{V}$ | - | 10 | 100 | nA |
| Drain to Source On Resistance (Note 2) | $r_{DS(ON)}$ | $I_D = 9\text{A}$, $V_{GS} = 10\text{V}$ (Figure 8) | - | 0.11 | 0.12 | Ω |
| Forward Transconductance (Note 2) | g_{fs} | $V_{DS} = 25\text{V}$, $I_D = 9\text{A}$ (Figure 11) | 3.0 | 5.2 | - | S |
| Turn-On Delay Time | $t_{d(ON)}$ | $V_{CC} = 30\text{V}$, $I_D \approx 3\text{A}$, $V_{GS} = 10\text{V}$, $R_{GS} = 50\Omega$, $R_L = 10\Omega$ | - | 20 | 30 | ns |
| Rise Time | t_r | | - | 55 | 85 | ns |
| Turn-Off Delay Time | $t_{d(OFF)}$ | | - | 70 | 90 | ns |
| Fall Time | t_f | | - | 80 | 110 | ns |
| Input Capacitance | C_{ISS} | $V_{DS} = 25\text{V}$, $V_{GS} = 0\text{V}$, $f = 1\text{MHz}$ (Figure 10) | - | 480 | 650 | pF |
| Output Capacitance | C_{OSS} | | - | 280 | 450 | pF |
| Reverse Transfer Capacitance | C_{RSS} | | - | 160 | 280 | pF |
| Thermal Resistance Junction to Case | $R_{\theta JC}$ | | ≤ 3.1 | | | $^\circ\text{C}/\text{W}$ |
| Thermal Resistance Junction to Ambient | $R_{\theta JA}$ | | ≤ 75 | | | $^\circ\text{C}/\text{W}$ |

Source to Drain Diode Specifications

| PARAMETER | SYMBOL | TEST CONDITIONS | MIN | TYP | MAX | UNITS |
|------------------------------------|-----------|---|-----|------|-----|---------------|
| Continuous Source to Drain Current | I_{SD} | $T_C = 25^\circ\text{C}$ | - | - | 13 | A |
| Pulsed Source to Drain Current | I_{SDM} | $T_C = 25^\circ\text{C}$ | - | - | 52 | A |
| Source to Drain Diode Voltage | V_{SD} | $T_J = 25^\circ\text{C}$, $I_{SD} = 26\text{A}$, $V_{GS} = 0\text{V}$, (Figure 12) | - | 1.6 | 2.2 | V |
| Reverse Recovery Time | t_{rr} | $T_J = 25^\circ\text{C}$, $I_{SD} = 13$, $dI_{SD}/dt = 100\text{A}/\mu\text{s}$, $V_R = 30\text{V}$ | - | 120 | - | ns |
| Reverse Recovery Charge | Q_{RR} | | - | 0.15 | - | μC |

NOTES:

2. Pulse Test: Pulse width $\leq 300\mu\text{s}$, duty cycle $\leq 2\%$.
3. Repetitive rating: pulse width limited by maximum junction temperature. See Transient Thermal Impedance curve (Figure 3).
4. $V_{DD} = 10\text{V}$, $T_J = 25^\circ\text{C}$, $L = 820\mu\text{H}$, $I_{PEAK} = 14\text{A}$. (See Figures 14 and 15).

Typical Performance Curves Unless Otherwise Specified

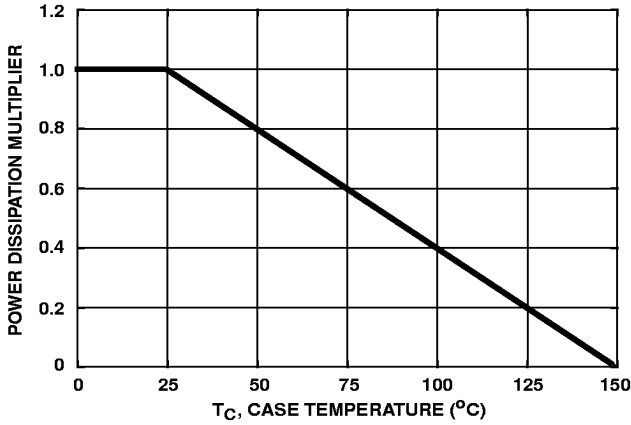

FIGURE 1. NORMALIZED POWER DISSIPATION vs CASE TEMPERATURE

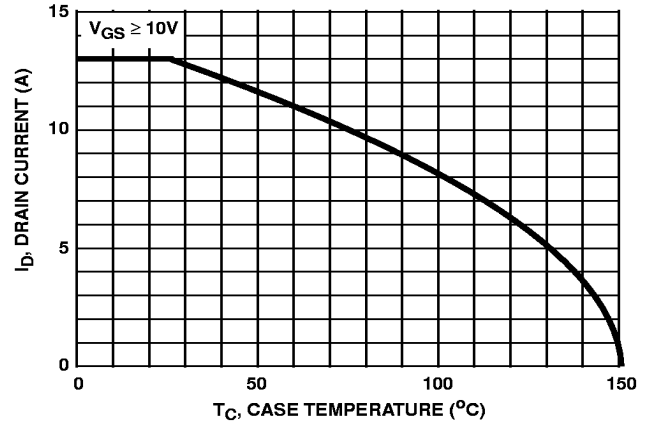

FIGURE 2. MAXIMUM CONTINUOUS DRAIN CURRENT vs CASE TEMPERATURE

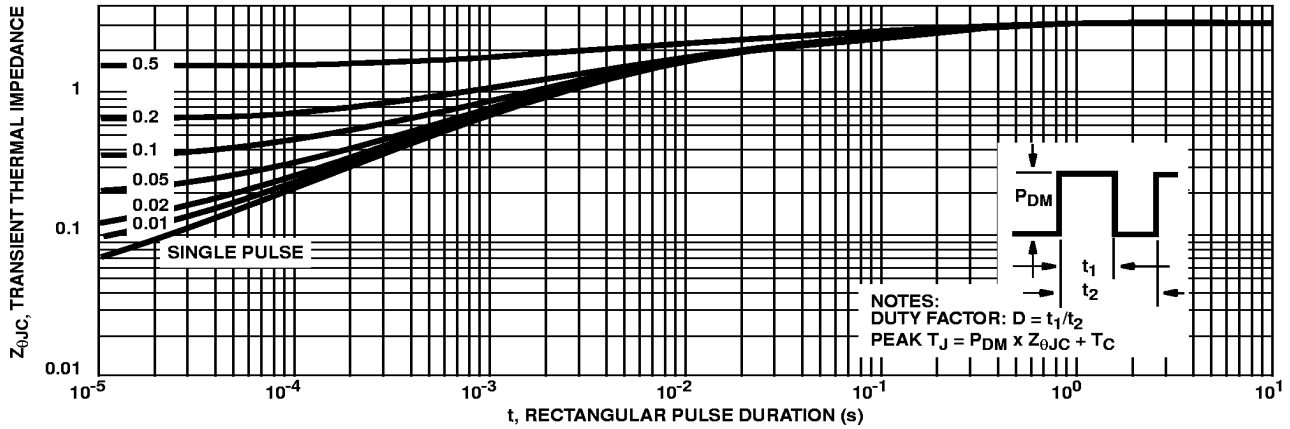

FIGURE 3. MAXIMUM TRANSIENT THERMAL IMPEDANCE

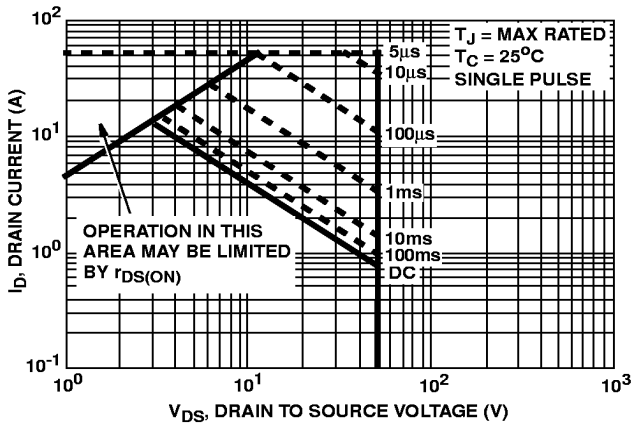

FIGURE 4. FORWARD BIAS SAFE OPERATING AREA

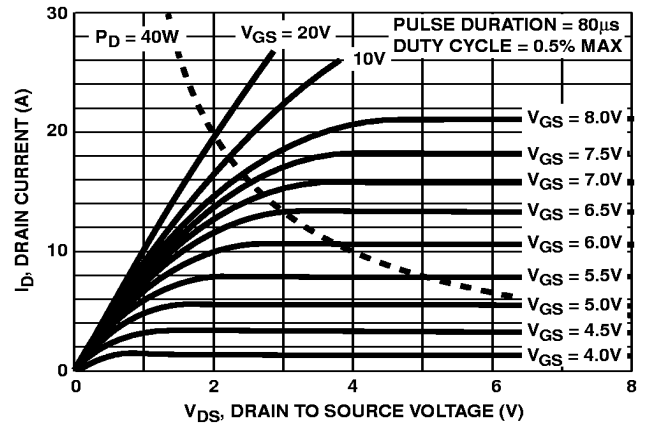

FIGURE 5. OUTPUT CHARACTERISTICS

Typical Performance Curves Unless Otherwise Specified (Continued)

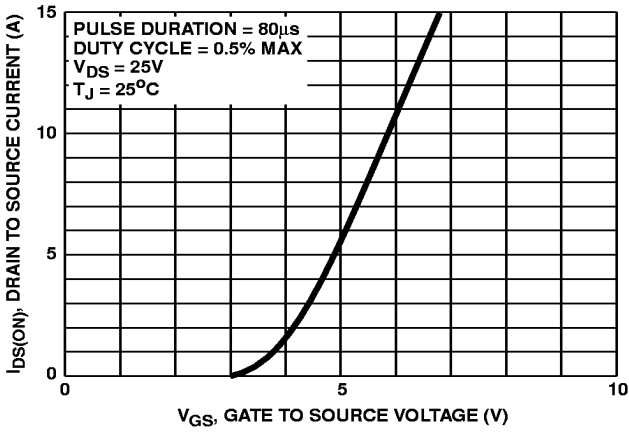

FIGURE 6. TRANSFER CHARACTERISTICS

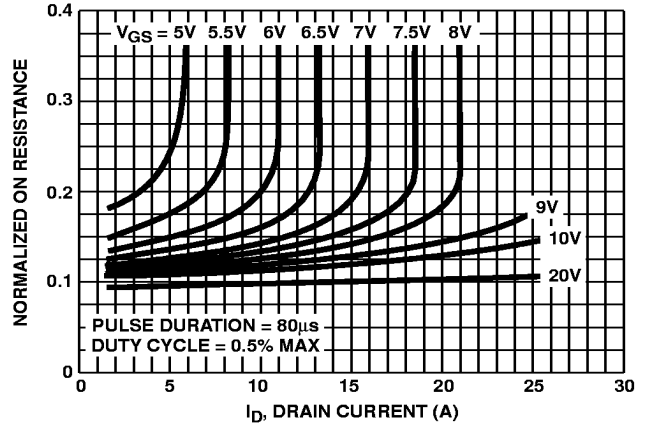

FIGURE 7. DRAIN TO SOURCE ON RESISTANCE vs GATE VOLTAGE AND DRAIN CURRENT

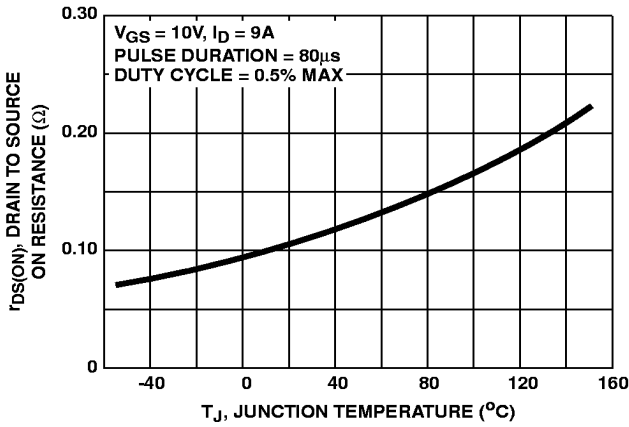

FIGURE 8. DRAIN TO SOURCE ON RESISTANCE vs JUNCTION TEMPERATURE

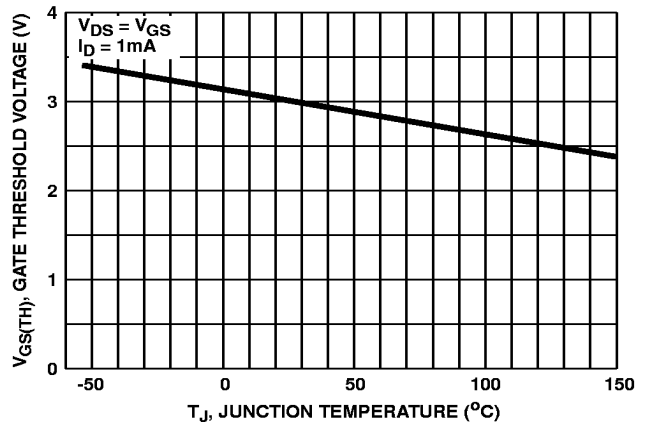

FIGURE 9. GATE THRESHOLD VOLTAGE vs JUNCTION TEMPERATURE

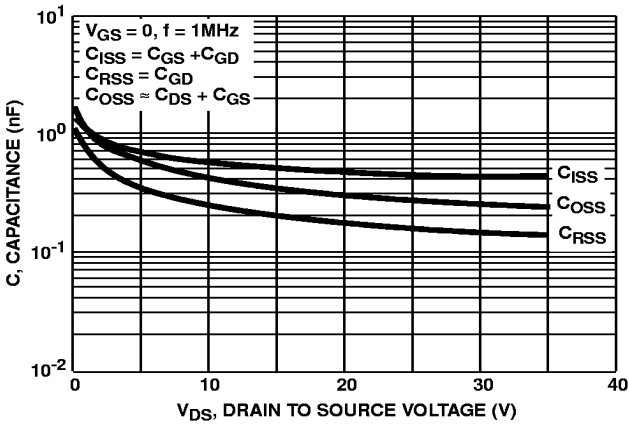

FIGURE 10. CAPACITANCE vs DRAIN TO SOURCE VOLTAGE

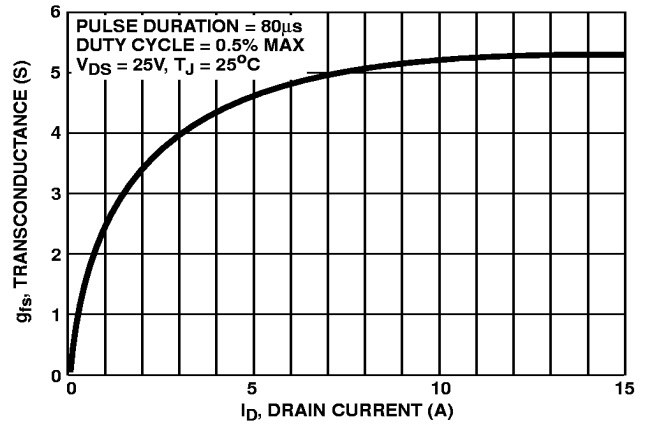

FIGURE 11. TRANSCONDUCTANCE vs DRAIN CURRENT

Typical Performance Curves Unless Otherwise Specified (Continued)

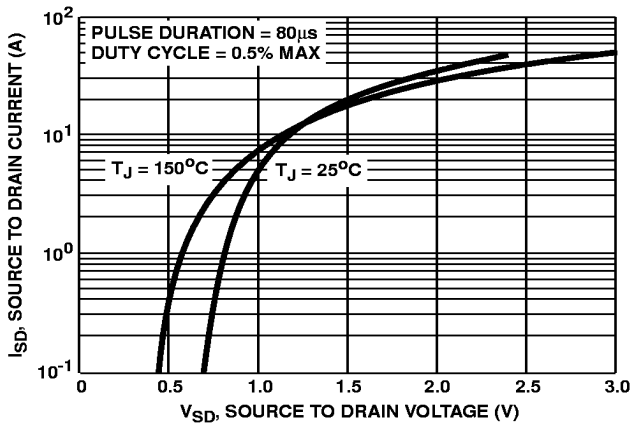

FIGURE 12. SOURCE TO DRAIN DIODE VOLTAGE

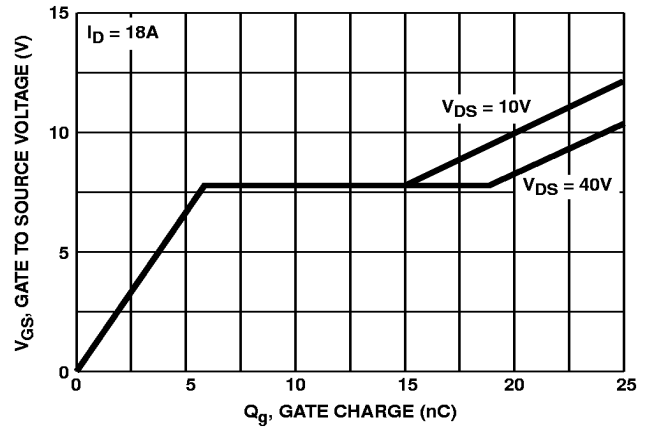

FIGURE 13. GATE TO SOURCE VOLTAGE vs GATE CHARGE

Test Circuits and Waveforms

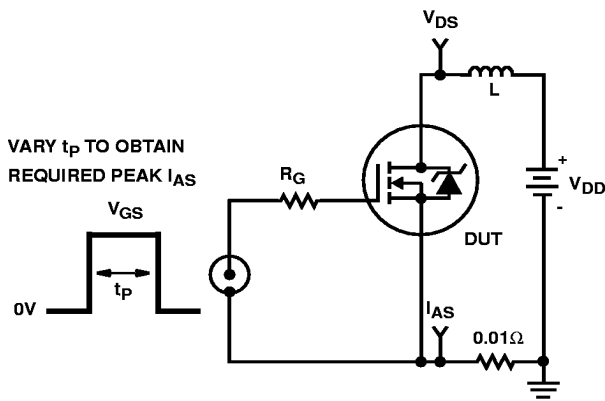

FIGURE 14. UNCLAMPED ENERGY TEST CIRCUIT

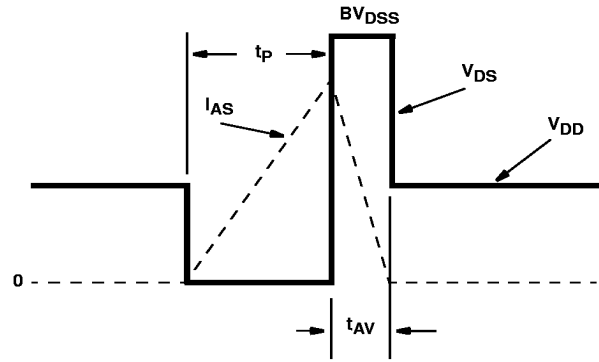

FIGURE 15. UNCLAMPED ENERGY WAVEFORMS

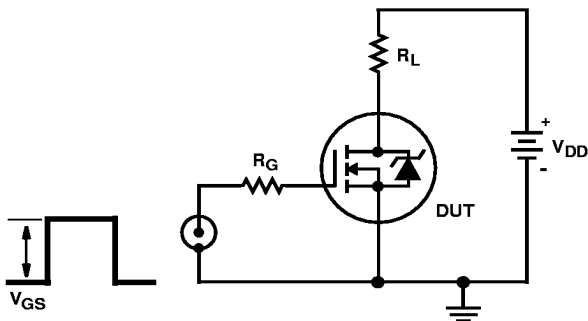

FIGURE 16. SWITCHING TIME TEST CIRCUIT

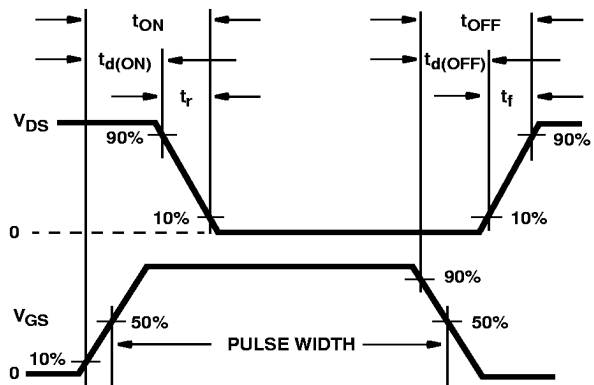

FIGURE 17. RESISTIVE SWITCHING WAVEFORMS

Test Circuits and Waveforms (Continued)

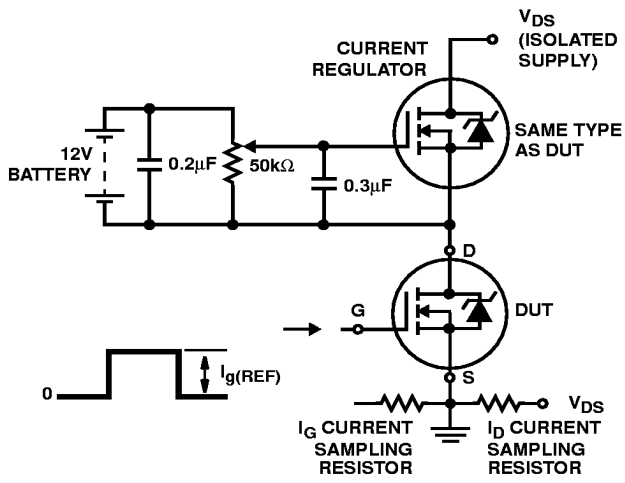

FIGURE 18. GATE CHARGE TEST CIRCUIT

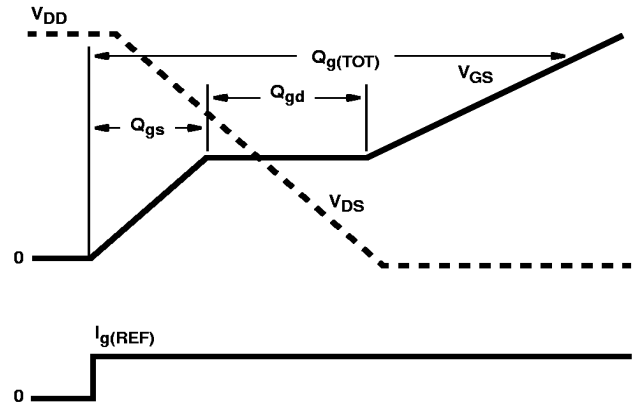

FIGURE 19. GATE CHARGE WAVEFORMS