

Reversible motor driver

BA6219B/BA6219BFP-Y

The BA6219B and BA6219BFP-Y are reversible-motor drivers suitable for brush motors. Two logic inputs allow four output modes : forward, reverse, idling, and braking. The motor revolving speed can be set arbitrarily by controlling the voltage applied to the motor.

●Applications

VCRs and cassette tape recorders

●Features

- 1) Large output current. ($I_o=2.2A$ maximally)
- 2) Built-in thermal shutdown circuit.
- 3) Built-in output voltage setting pins.
- 4) Small standby circuit current.

●Block diagram

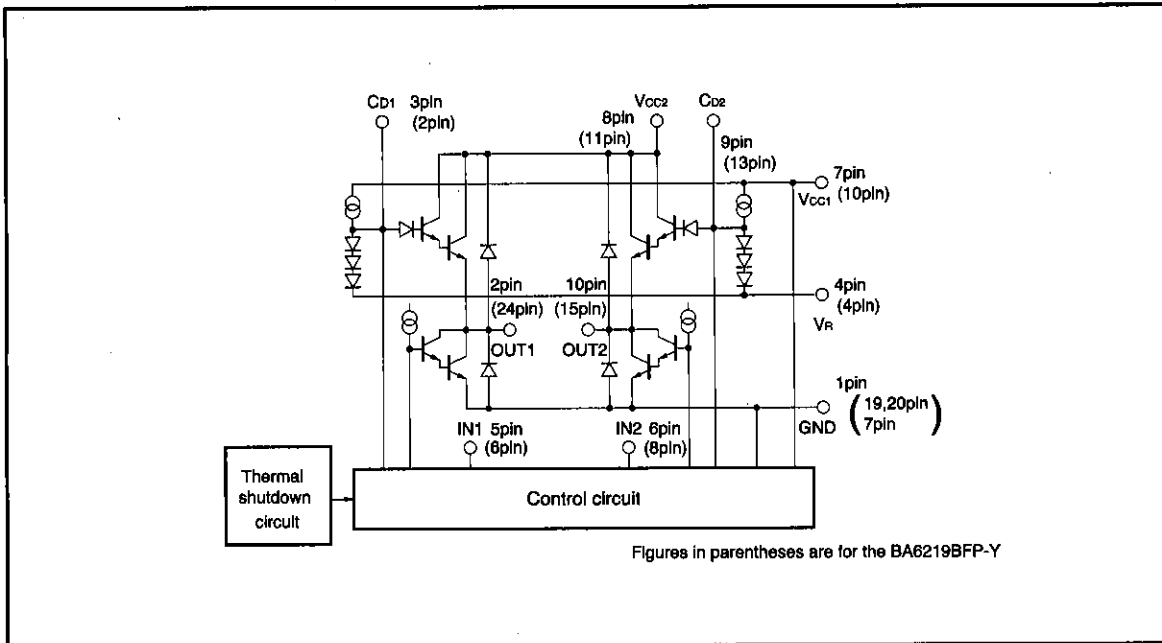

●Absolute maximum ratings (Ta=25°C)

Parameter	Symbol	Limits	Unit
Power supply voltage	Vcc1, Vcc2	24	V
Power dissipation	BA6219B	2200*1	mW
	BA6219BFP - Y	1450*2	
Operating temperature	Topr	-20~75	°C
Storage temperature	Tstg	-50~125	°C
Output current	Io	2.2*3	A
Input voltage	VIN	-0.3~Vcc1	V

*1 Reduce power by 22 mW for each degree above 25°C.

*2 Mounted on a 90 X 50 X 1.6 mm glass epoxy board.
Reduce power by 14.5 mW for each degree above 25°C.

*3 500 μs pulse with a duty ratio of 1%.

●Recommended operating conditions (Ta=25°C)

Parameter	Symbol	Min.	Typ.	Max.	Unit
Operating power supply voltage	Vcc1	8	—	18	V
	Vcc2				

●Electrical characteristics (unless otherwise noted, Ta=25°C and Vcc=12V)

Parameter	Symbol	Min.	Typ.	Max.	Unit	Conditions
Current consumption 1	Icc1	—	1.2	2.5	mA	Both input pins LOW
Current consumption 2	Icc2	—	16	35	mA	One input pin HIGH, the other LOW
Current consumption 3	Icc3	—	25	60	mA	Both input pins HIGH
Input threshold voltage	VTH	1.0	2.0	3.0	V	Low level is 1 V or less, HIGH level is 3 V or more
Output voltage HIGH	VH	6.5	—	—	V	RL=60Ω, ZD=6.8V
Output voltage LOW	VL	—	—	1.2	V	RL=60Ω

●Electrical characteristic curves

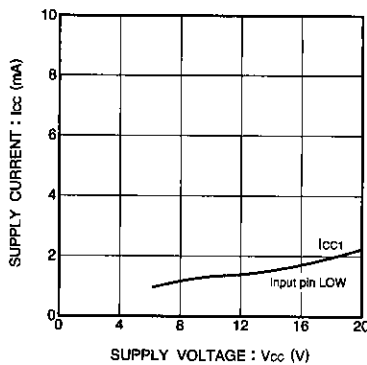

Fig.1 Current consumption 1 vs. power supply voltage

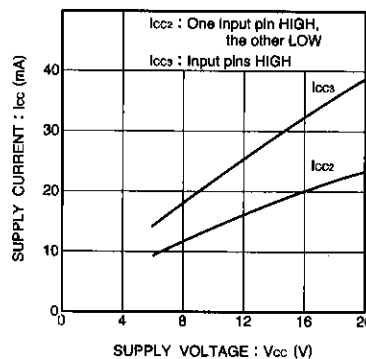

Fig.2 Current consumption 2,3 vs. power supply voltage

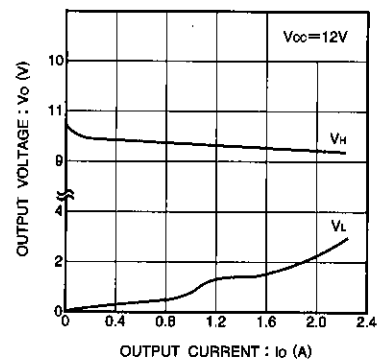

Fig.3 Output voltage vs. output current

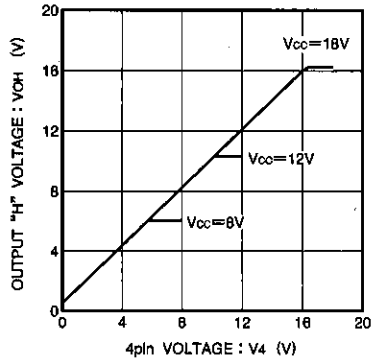

Fig.4 Output voltage vs. 4 pin voltage

● Measurement circuits

BA6219BFP-Y

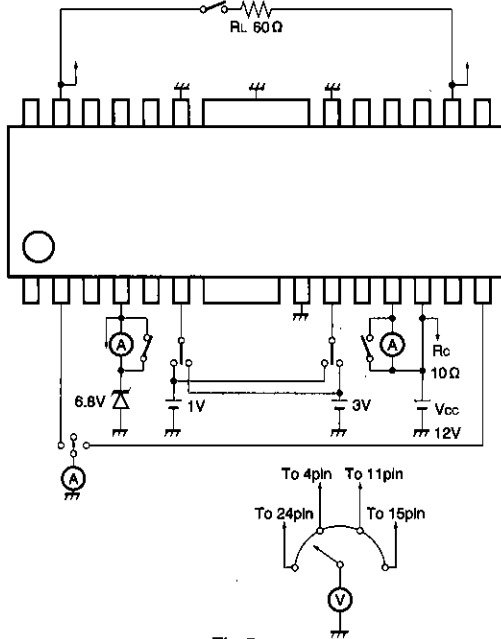

Fig.5

BA6219B

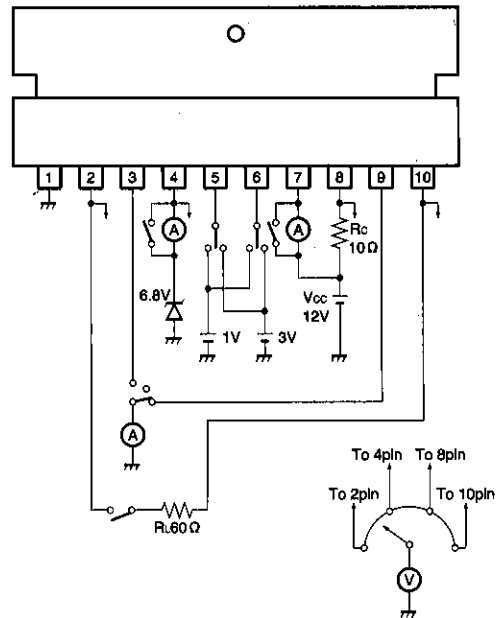

Fig.6

● Circuit operation

Input		Output		Mode
IN1	IN2	OUT1	OUT2	
L	L	OPEN	OPEN	Idling
H	L	H	L	Forward
L	H	L	H	Reverse
H	H	L	L	Braking

Note: HIGH level Input is 3.0 V or more
 LOW level input is 1.0 V or less

●Pin description
(BA6219BFP-Y)

Pin No.	Pin name	Function
1	—	NC
2	C _{D1}	Capacitor connection pin for preventing both output transistors being turned on at the same time
3	—	NC
4	V _R	Output HIGH voltage setting pin
5	—	NC
6	IN1	Logic input pin
7	GND	GND
8	IN2	Logic input pin
9	—	NC
10	V _{CC1}	Small signal section power supply pin
11	V _{CC2}	Motor output power supply pin
12	—	NC
13	C _{D2}	Capacitor connection pin for preventing both output transistors being turned on at the same time
14	—	NC
15	OUT2	Motor output pin
16	—	NC
17	—	NC
18	—	NC
19	GND	GND
20	GND	GND
21	—	NC
22	—	NC
23	—	NC
24	OUT1	Motor output pin
25	—	NC
Fin	GND	GND

(BA6219B)

Pin No.	Pin name	Function
1	GND	GND
2	OUT 1	Motor output pin
3	C _{D1}	Capacitor connection pin for preventing both output transistors being turned on at the same time
4	V _R	Output HIGH voltage setting pin
5	IN1	Logic input pin
6	IN2	Logic input pin
7	V _{CC1}	Control circuit power supply pin
8	V _{CC2}	Output power supply pin
9	C _{D2}	Capacitor connection pin for preventing both output transistors being turned on at the same time
10	OUT 2	Motor output pin

* All the GND pins have to be connected

● Operation notes

(1) A schematic for the internal circuit associated with the output voltage setting pin (Pin 4) is shown in Fig. 7.

The maximum output voltage ($V_{OMAX.}$) is given by :

$$V_{OMAX.} = V_{CC1} - V_{SAT(Q1)} - V_{BE(Q2)} - V_{BE(Q3)} - V_{BE(Q4)}$$

For the condition of V_b being equal to or less than $V_{OMAX.}$, the relationship between the output voltage (V_o) and the pin 4 voltage is given by :

$$V_o = V_R + \{V_{BE(Q5)} + V_{BE(Q6)} + V_{BE(Q7)}\} - \{V_{BE(Q2)} + V_{BE(Q3)} + V_{BE(Q4)}\}$$

Though ΔV_{BE} depends on the output power supply, V_o is nearly equal to V_R .

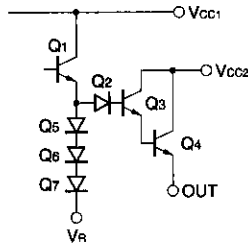

Fig.7

(2) Thermal shutdown circuit

The thermal shutdown circuit turns off the driver output if the chip temperature rises to about 180°C. The shutdown signal is not latched.

(3) Power supply impedance

When the motor stops or starts, a rush current flows in the V_{CC} and GND lines. Depending on the way of connecting a power supply decoupling capacitor (100 μ F), the control input voltage may become a negative value or the supply voltage may drop to below the output voltage. This can cause erratic operations due to parasitic effects.

Make sure that pin voltages will not exceed the supply voltage by more than 0.3V or will not become less than the GND pin voltage by more than 0.3V.

(4) V_{CC1} , V_{CC2} , and V_R are related to each other as shown in the output circuit diagram of Fig. 8. Their values should be kept within the following ranges.

Operating supply voltage ranges

Pin	Voltage	Unit
V_{CC1}	8~18	V
V_{CC2}	8~18	V
V_R	Indicated in the following	—

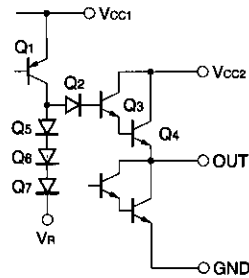

Fig.8

1) When the output voltage control pin (pin 4) is not used

$$V_R < V_{CC1} - V_{SAT(Q1)} + V_{BE(Q5)} + V_{BE(Q6)} + V_{BE(Q7)} \cong V_{CC1} - 2.5V$$

$$V_R < V_{CC2} - \{V_{SAT(Q3)} - V_{BE(Q3)} - V_{BE(Q3)} - V_{BE(Q2)}\} + \{V_{BE(Q5)} + V_{BE(Q6)} + V_{BE(Q7)}\} \cong V_{CC2} - 1V$$

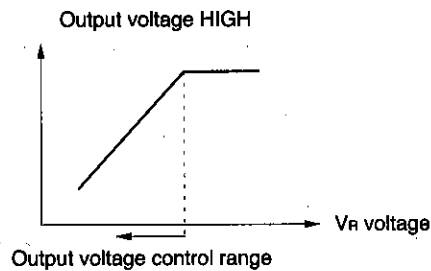
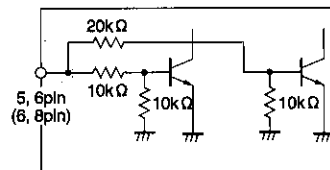

Fig.9

2) When pin 4 is not used, V_R is either short-circuited to V_{CC1} or left OPEN.

(5) Input circuit



Figures in parentheses are for the BA6219BFP-Y

Fig.10

●Application example

(1) BA6219B

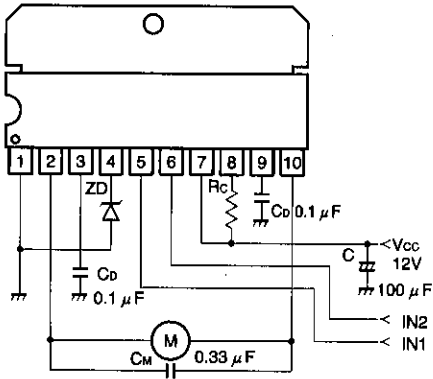

Fig.11

(2) BA6219BFP-Y

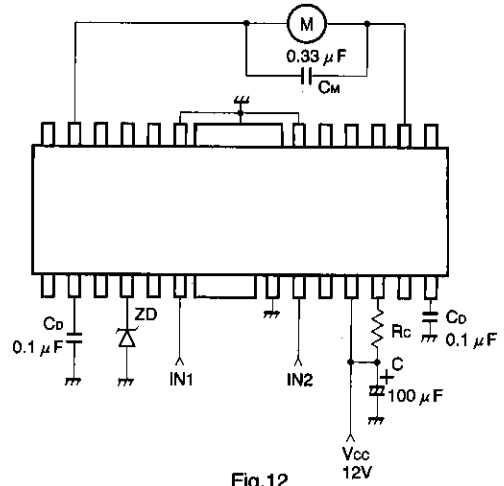

Fig.12

- ZD : Zener diode to set output voltage. Use any zener diode that is suitable for your application.
- Rc : Resistor used for reducing collector loss and limiting the short-circuit current. A resistance range of 3 ~ 10Ω is recommended.
- C : Power supply filtering capacitor. Place as near as possible to the Vcc1 pin.
- Cd : Capacitor to prevent both output transistors being turned on at the same time.
- Cm : Capacitor to absorb surge voltage and prevent parasitic oscillations.

●External dimensions (Units: mm)

