

Dual preamplifier with ALC

BA3308 / BA3308F

The BA3308 and BA3308F are dual preamplifier ICs with built-in ALC circuits, and have been designed for use in stereo radio-cassette recorders and tape recorders. They come in compact 9-pin SIP (BA3308) and 14-pin MF (BA3308F) packages, and have two record / playback preamplifiers, and an ALC circuit. The preamplifiers have high gain and low distortion, and can be directly coupled to the tape head without coupling capacitors. This prevents tape head magnetization and "pop" noise generation.

A built-in rectifier means that an ALC circuit with good channel balance and large dynamic range can be constructed with addition of just an external time constant circuit.

The ICs also include power-on mute circuits that suppress "pop" noise generation.

●Applications

Stereo radio cassette recorders, cassette decks and home stereo systems and music centers

●Features

- 1) Built-in ALC rectifier diode.
- 2) Wide operating power supply voltage range ($V_{CC}=6.0V$ to $14V$)
- 3) Low current dissipation ($I_C=3.5mA$)
- 4) High gain ($G_{VO}=80dB$)
- 5) Low distortion (THD=0.1%)
- 6) Low noise ($V_{NIN}=1\mu V_{rms}$)
- 7) Input coupling capacitors and not necessary.
- 8) Good ALC channel balance.
- 9) Power-on mute circuit.
- 10) ALC dynamic range can be varied by the addition of an external input resistor.

●Absolute maximum ratings ($T_a=25^\circ C$)

Parameter	Symbol	Limits	Unit
Power supply voltage	V_{CC}	16	V
Power dissipation	BA3308	950 *1	mW
	BA3308F	450 *2	
Operating temperature	T_{opr}	-25 to +75	$^\circ C$
Storage temperature	T_{stg}	-55 to +125	$^\circ C$

*1 Reduced by 9.5mW for each increase in T_a of $1^\circ C$ over $25^\circ C$.

*2 Reduced by 4.5mW for each increase in T_a of $1^\circ C$ over $25^\circ C$
(when mounted on a $70mm \times 70mm \times 1.6mm$ glass epoxy board).

●Recommended operating conditions ($T_a=25^\circ C$)

Power supply voltage range 1	+6.0V~+14V ($T_a=25\sim+75^\circ C$)
Power supply voltage range 2	+4.5V~+14V ($T_a=0\sim+75^\circ C$)

*When it is used below $T_a=0^\circ C$, please use it within the range of operating power supply voltage 1.

Audio ICs

●Block diagram

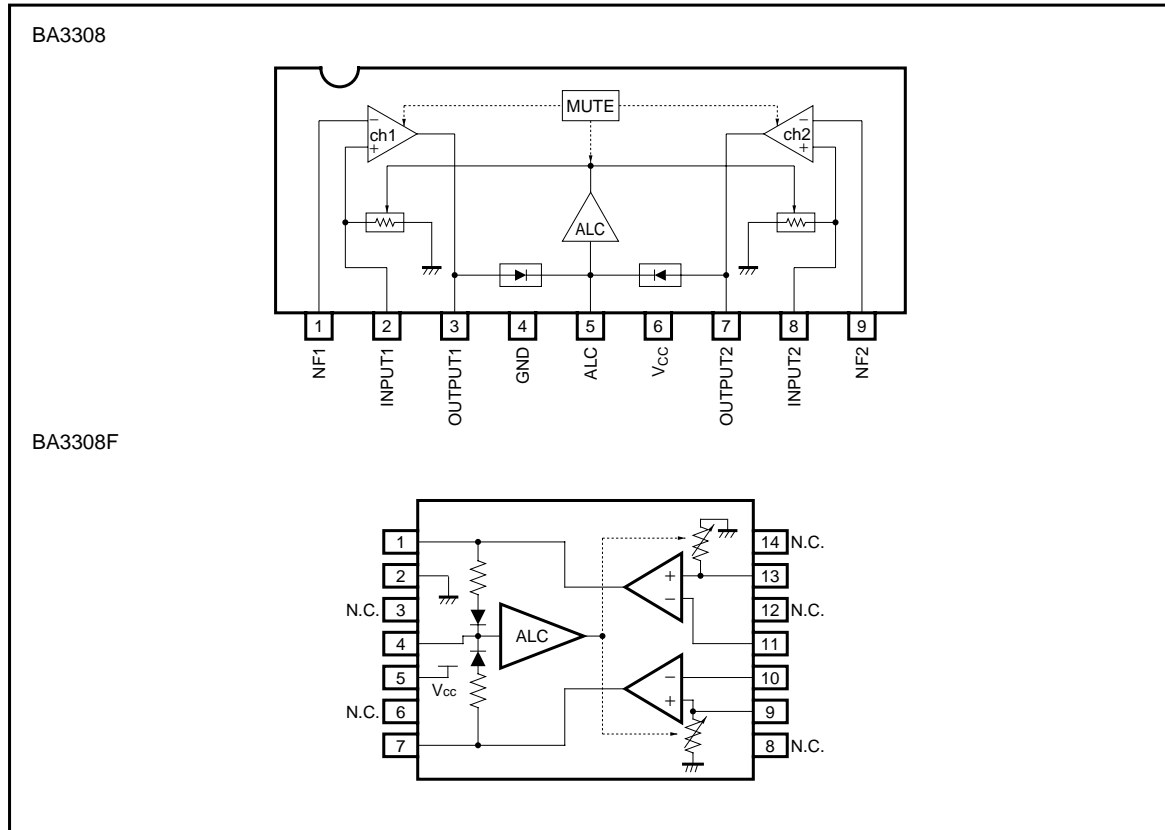

●Electrical characteristics (unless otherwise noted, Ta=25°C, Vcc=7.0V, f=1kHz and BPF: 20Hz~20kHz)

Parameter	Symbol	Min.	Typ.	Max.	Unit	Conditions
Quiescent current	Iq	1.5	3.5	4.5	mA	VIN=0Vrms
Open loop voltage gain	Gvo	70	80	-	dB	VOUT=-10dBV
Total harmonic distortion	THD	-	0.1	0.3	%	NAB34dB, VOUT=40mVrms
Input resistance	RIN	15	25	45	kΩ	-
Maximum output voltage	Vom	0.6	1.2	-	Vrms	THD=1%
Input conversion noise voltage	VNIN	-	1.0	2.0	μVrms	Conversion with Rg=2.2kΩ and NAB34dB at 1kHz
ALC range	ALC	40	45	-	dB	Rg=3.9kΩ, VIN=-70dBV reference, THD=3%
ALC channel balance	ΔALC	-	0	2.5	dB	VIN=-60dBV, -30dBV
Channel separation	CS	60	75	-	dB	Vo=0dBV, NAB34dB

Audio ICs

●Total application circuit

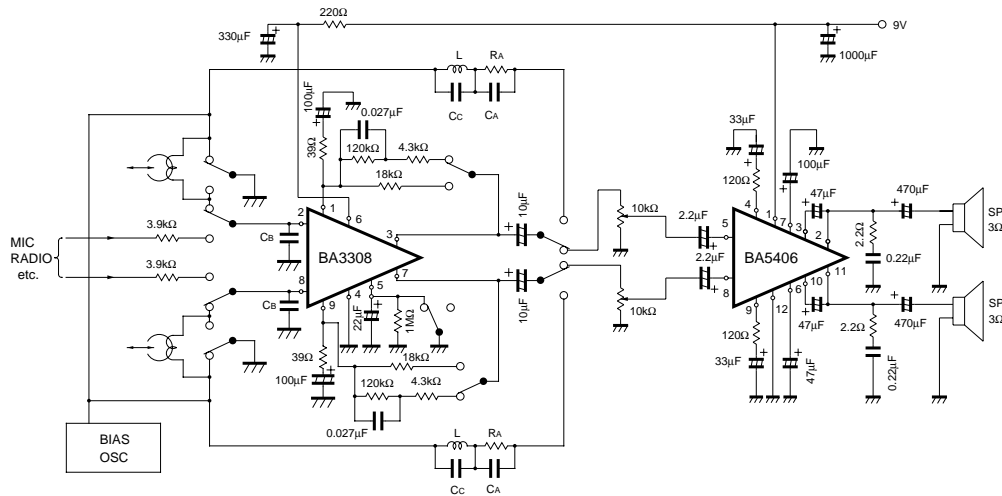

Notes:

- (1) Switches are in the playback positions.
- (2) Set the values of R_A and C_A depending on the characteristics of the playback/recording head.
- (3) The capacitor C_B is for head resonance treble compensation during playback, and prevention of high-frequency noise. The recommended value is about 1000pF.
- (4) L and C_C are a bias trap.

Fig. 4

●Circuit operation

(1) Recording

1) Recording amplifier (See Fig.5)

The channel 1 and 2 amplifier input stages of the BA3308 (pins 8 and 2) and be direct-coupled, and the input coupling capacitors C_1 and C_2 are not particularly required. The voltage gain of the recording amplifier is given by $G_v = R_5 / R_3$, but as a "pop" noise is generated when power is applied, (see "operation notes"), use the time constant circuit values given for C_3 and R_3 (C_4 and R_4) in the application example circuit diagram, or values close to these, and adjust the voltage gain with R_5 (R_6). R_5 (R_6) is also the DC bias feedback resistor, and is connected between pin 3 (7), and the output capacitor C_5 (C_6).

2) ALC (See Fig.6)

The BA3308 includes a signal rectifier block and electronic potentiometers required for the ALC. In the signal rectifier block, a comparator compares the DC output voltage component of the output stage signal (pins 3 and 7) to a voltage of $4.5V_F$ ($1V_F$ is about 0.7V, so $4.5V_F$ is approximately 3V), and if it is above this, the comparator switches on, and changes the smoothing capacitor C_7 . The operating point of the amplifier's ch1 and ch2 output stages is fixed at $3V_F$, so when the signal output voltage is $1.5V_F$ (an effective value of approximately 0.75V), the comparator goes on, DC signals for electronic potentiometer control are generated, and the ALC starts operating. The electronic potentiometers are connected between the input lines (pins 2 and 8) and GND, and the input signals is attenuated by the ratio of the electronic potentiometer resistances and the external resistors R_1 and R_2 . The range of the ALC can be varied by the values of R_1 and R_2 , but if they are too large the S/N ratio will worsen. Sufficient ALC range should be obtained with R_1 and R_2 values of around several k ohms. C_7 and C_8 connected to pin 5 set the ALC attack and recovery times. The larger the values of these constants, the longer the recovery time, and the smaller the value of C_7 the shorter the attack time.

Audio ICs

(2) Playback (See Fig.7)

During playback, the ch1 and ch2 amplifiers are used as NAB equalizer amplifiers, and time constant circuits are connected between pins 1 and 3, and 7 and 9 in the negative-feedback section to give the NAB characteristics.

The voltage gain is given by:

$$G_v = |R_{11} + R_9 / (1 + j\omega C_9 \cdot R_9)| / R_3$$

In the same way as for recording, the NAB time constant circuit is adjusted to give the required gain (to prevent generation of a "pop" noise when power is applied). The output stage (pins 3 and 7) operating point is fixed at 3V_F.

Therefore, as indicated in the V_{MAX}. VS. V_{CC} characteristic (see Fig.19), even if the V_{CC} voltage is made larger than 5V, the maximum output voltage will not exceed 1.2V (typ.). The ALC circuit is not required for playback, so pin 5 is grounded. The S/N ratio during playback is better if the external resistors R₁ and R₂ that are connected to the input pins (2 and 8) for recording are switched out.

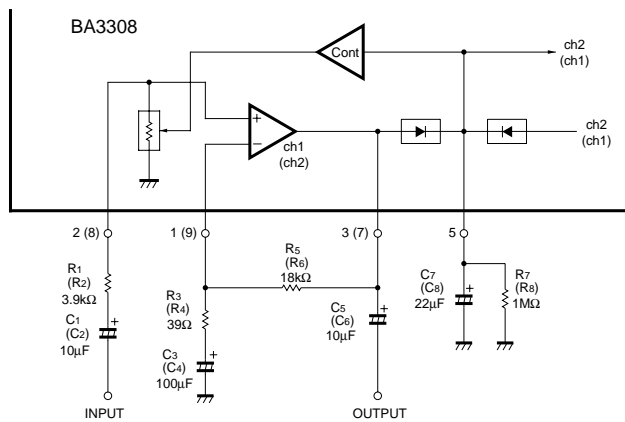

Fig.5

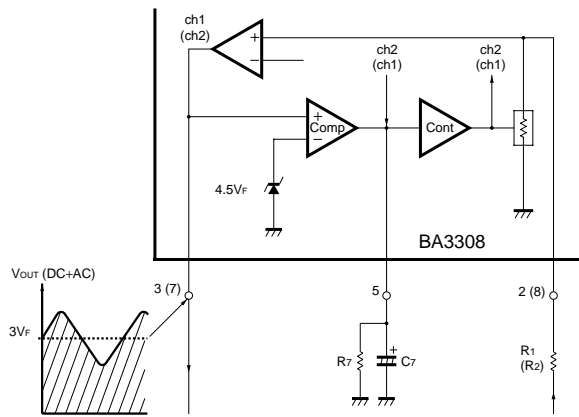

Fig.6

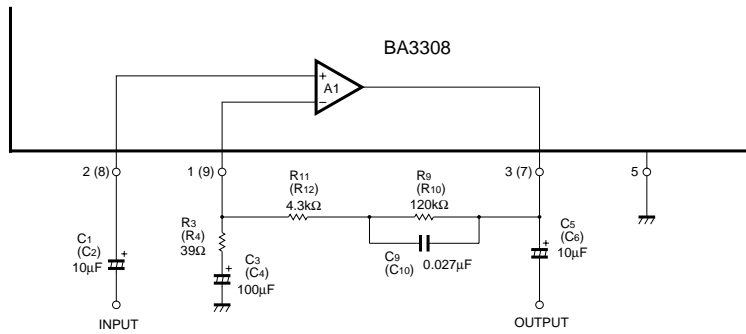

Fig.7

●Operation notes

The BA3308 has a built-in power-on mute circuit to prevent generation of a “pop” sound when the power is applied. The generation of the “pop” sound is prevented by the DC blocking capacitors C₃ and C₄ connected to pins 1 and 9, and the charge time required for the ripple filter capacitor C₈ that is connected to pin 6.

To ensure correct operation of this circuit, use the values given in the application example circuit for C₃, C₄, R₃, R₄, C₈ and R₈.

●Application board component layout (component side)

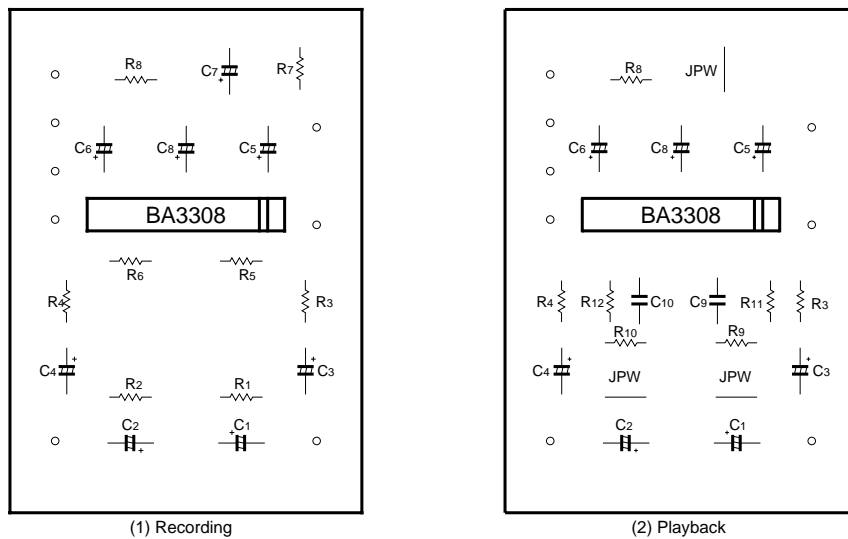

Fig.8

Audio ICs

●Electrical characteristic curves

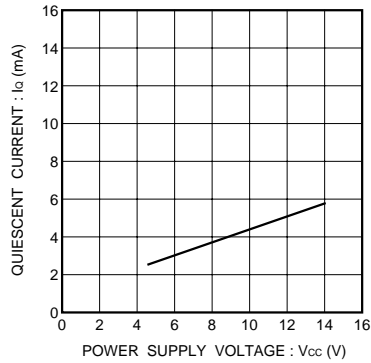

Fig.9 Quiescent current vs. power supply voltage

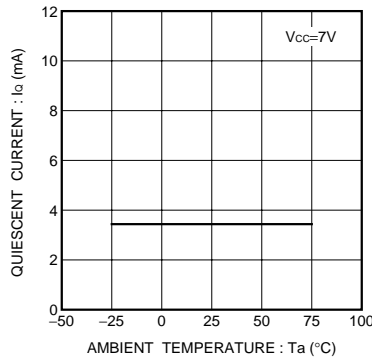

Fig.10 Quiescent current vs. ambient temperature

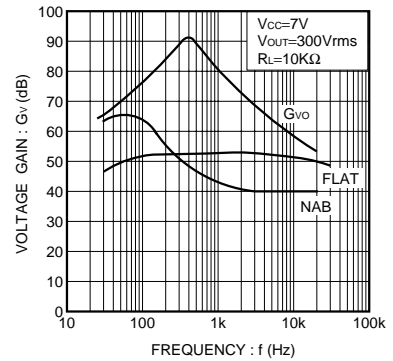

Fig.11 Voltage gain vs. frequency

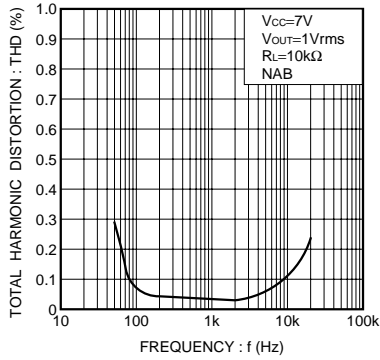

Fig.12 Total harmonic distortion vs. frequency

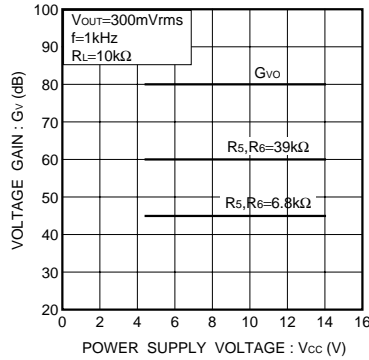

Fig.13 Voltage gain vs. power supply voltage

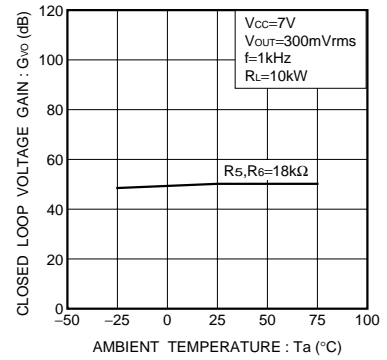

Fig.14 Closed loop voltage gain vs. ambient temperature

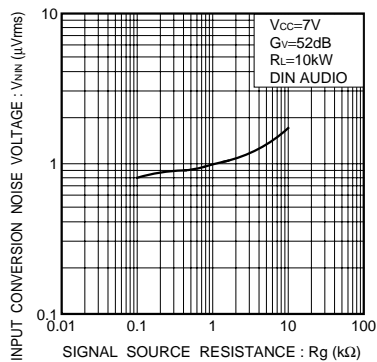

Fig.15 Input conversion noise voltage vs. signal source resistance

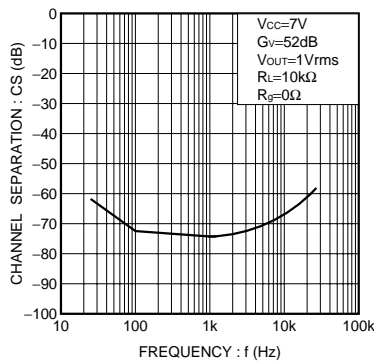

Fig.16 Channel separation vs. frequency

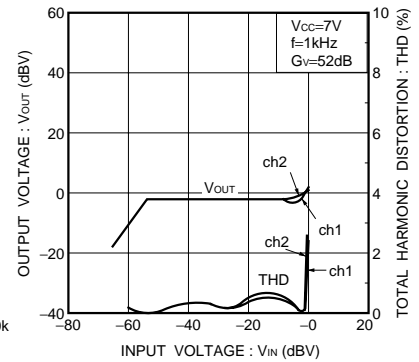

Fig.17 ALC characteristics

Audio ICs

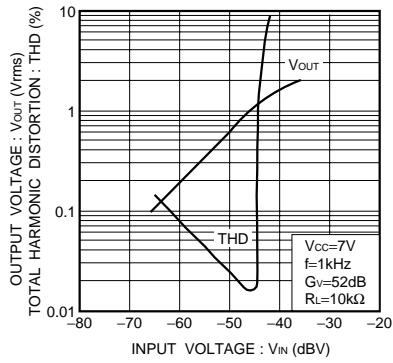

Fig.18 Input/output characteristics

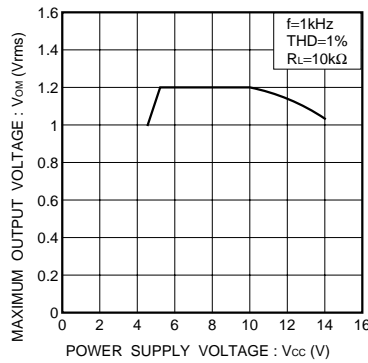

Fig.19 Maximum output voltage vs. power supply voltage

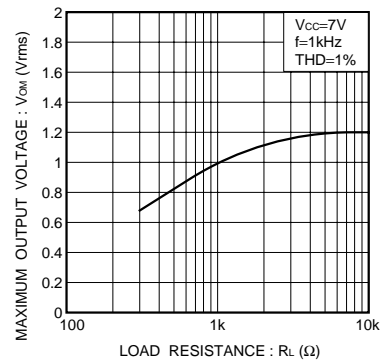
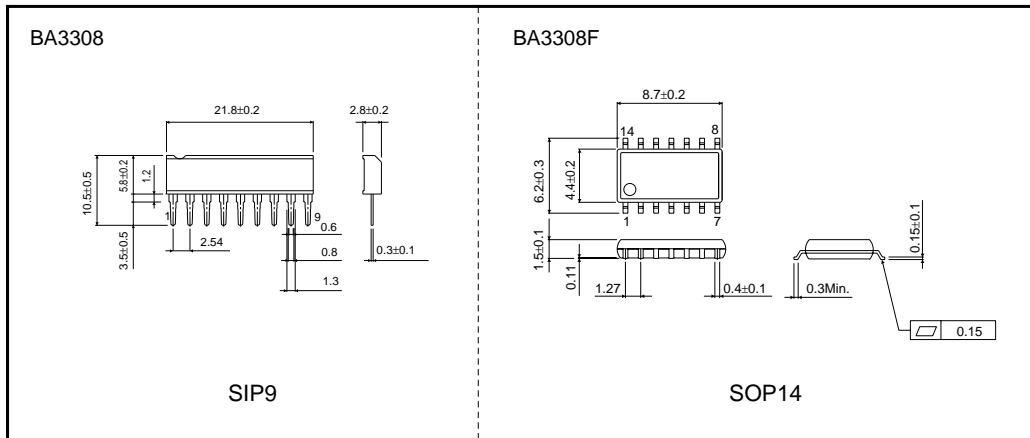

Fig.20 Maximum output voltage vs. load resistance

●External dimensions (Units : mm)



Notes

- No technical content pages of this document may be reproduced in any form or transmitted by any means without prior permission of ROHM CO.,LTD.
- The contents described herein are subject to change without notice. The specifications for the product described in this document are for reference only. Upon actual use, therefore, please request that specifications to be separately delivered.
- Application circuit diagrams and circuit constants contained herein are shown as examples of standard use and operation. Please pay careful attention to the peripheral conditions when designing circuits and deciding upon circuit constants in the set.
- Any data, including, but not limited to application circuit diagrams information, described herein are intended only as illustrations of such devices and not as the specifications for such devices. ROHM CO.,LTD. disclaims any warranty that any use of such devices shall be free from infringement of any third party's intellectual property rights or other proprietary rights, and further, assumes no liability of whatsoever nature in the event of any such infringement, or arising from or connected with or related to the use of such devices.
- Upon the sale of any such devices, other than for buyer's right to use such devices itself, resell or otherwise dispose of the same, no express or implied right or license to practice or commercially exploit any intellectual property rights or other proprietary rights owned or controlled by
- ROHM CO., LTD. is granted to any such buyer.
- Products listed in this document use silicon as a basic material.
Products listed in this document are no antiradiation design.

The products listed in this document are designed to be used with ordinary electronic equipment or devices (such as audio visual equipment, office-automation equipment, communications devices, electrical appliances and electronic toys).

Should you intend to use these products with equipment or devices which require an extremely high level of reliability and the malfunction of which would directly endanger human life (such as medical instruments, transportation equipment, aerospace machinery, nuclear-reactor controllers, fuel controllers and other safety devices), please be sure to consult with our sales representative in advance.

About Export Control Order in Japan

Products described herein are the objects of controlled goods in Annex 1 (Item 16) of Export Trade Control Order in Japan.

In case of export from Japan, please confirm if it applies to "objective" criteria or an "informed" (by MITI clause) on the basis of "catch all controls for Non-Proliferation of Weapons of Mass Destruction.