

Features

- Number of Keys:
 - One toggle mode (touch-on/touch-off), plus programmable auto-off delay and external cancel
 - Configurable as either a single key or a proximity sensor
- Technology:
 - Patented spread-spectrum charge-transfer (direct mode)
- Key outline sizes:
 - 6 mm x 6 mm or larger (panel thickness dependent); widely different sizes and shapes possible
- Electrode design:
 - Solid or ring electrode shapes
- PCB Layers required:
 - One
- Electrode materials:
 - Etched copper, silver, carbon, Indium Tin Oxide (ITO)
- Electrode substrates:
 - PCB, FPCB, plastic films, glass
- Panel materials:
 - Plastic, glass, composites, painted surfaces (low particle density metallic paints possible)
- Panel thickness:
 - Up to 12 mm glass, 6 mm plastic (electrode size and Cs dependent)
- Key sensitivity:
 - Settable via external capacitor (Cs)
- Interface:
 - Digital output, active high or active low (hardware configurable)
- Moisture tolerance:
 - Good
- Power:
 - 1.8V ~ 5.5V; 32.5 μ A at 1.8V
- Package:
 - 6-pin SOT23-6 (3 x 3 mm) RoHS compliant
- Signal processing:
 - Self-calibration, auto drift compensation, noise filtering
- Applications:
 - Power switch replacement in countertop appliances, irons, battery powered toys, heaters, lighting controls, automotive interior lighting, commercial and industrial equipment such as soldering stations and cooking equipment
- Patents:
 - QTouch® (patented charge-transfer method)



One-channel Toggle-mode Touch Sensor IC with Power Management Functions

AT42QT1012

Summary

Note: This is a summary document.
A complete document is available.
For more information contact
www.atmel.com/touch.

9543CS-AT42-02/10



1. Pinout and Schematic

1.1 Pinout Configuration

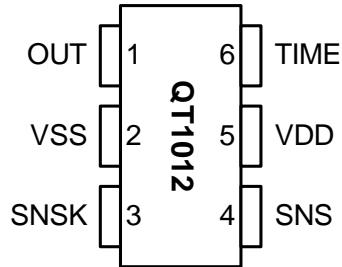

1.2 Pin Descriptions

Table 1-1. Pin Listing

Pin	Name	Type	Comments
1	OUT	O	Output state. To switched circuit and output polarity selection resistor (Rop)
2	Vss	P	Supply ground
3	SNSK	I/O	Sense pin. To Cs capacitor and to sense electrode
4	SNS	I/O	Sense pin. To Cs capacitor and multiplier configuration resistor (Rm). Rm must be fitted and connected to either VSS or VDD.
5	Vdd	P	Power
6	TIME	I	Timeout configuration pin. Must be connected to either VSS, VDD, OUT or an RC network.

I Input only

O Output only, push-pull

I/O Input and output

P Ground or power

1.3 Schematic

Figure 1-1. Basic Circuit Configuration
(active high output, toggle on/off, no auto switch off)

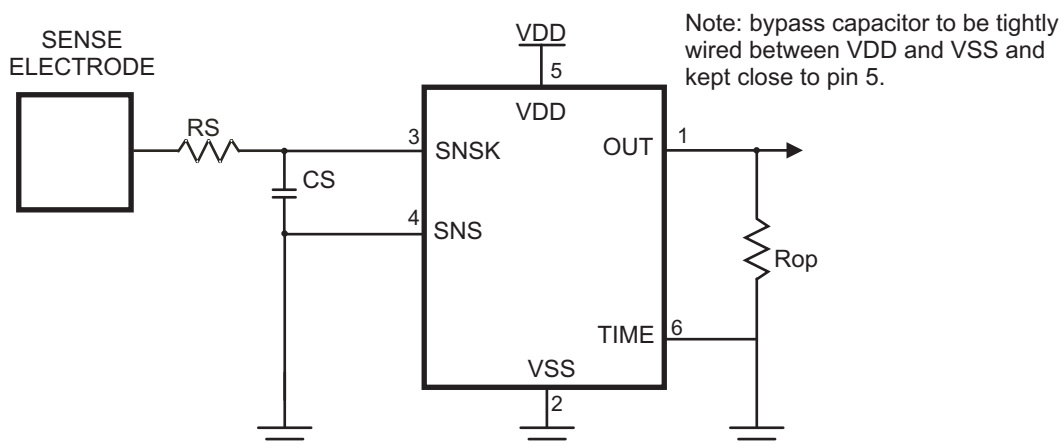

2. Overview of the AT42QT1012

2.1 Introduction

The AT42QT1012 (QT1012) is a single key device featuring a touch on/touch off (toggle) output with a programmable auto switch-off capability.

The QT1012 is a digital burst mode charge-transfer (QT™) sensor designed specifically for touch controls. It includes all hardware and signal processing functions necessary to provide stable sensing under a wide variety of changing conditions; only low cost, noncritical components are required for operation. With its tiny low-cost SOT-23 package, this device can suit almost any product needing a power switch or other toggle-mode controlled function, especially power control of small appliances and battery-operated products.

A unique “green” feature of the QT1012 is the timeout function, which can turn off power after a specified time delay ranging from minutes to an hour.

Like all QTouch® devices, the QT1012 features automatic self-calibration, drift compensation, and spread-spectrum burst modulation in order to provide for the most reliable touch sensing possible.



Revision History

Revision No.	History
Revision A – August 2009	<ul style="list-style-type: none">• Initial release for chip revision 2.4
Revision B – September 2009	<ul style="list-style-type: none">• Changes to Cs value.
Revision CS – February 2010	<ul style="list-style-type: none">• Updated for chip revision 3.1

Notes



Headquarters

Atmel Corporation
2325 Orchard Parkway
San Jose, CA 95131
USA
Tel: 1(408) 441-0311
Fax: 1(408) 487-2600

International

Atmel Asia
Unit 01-05 & 16, 19/F
BEA Tower, Millennium City 5
418 Kwun Tong Road
Kwun Tong
Kowloon
Hong Kong
Tel: (852) 2245-6100
Fax: (852) 2722-1369

Atmel Europe
Le Krebs
8, Rue Jean-Pierre Timbaud
BP 309
78054 Saint-Quentin-en-
Yvelines Cedex
France
Tel: (33) 1-30-60-70-00
Fax: (33) 1-30-60-71-11

Atmel Japan
9F, Tonetsu Shinkawa Bldg.
1-24-8 Shinkawa
Chuo-ku, Tokyo 104-0033
Japan
Tel: (81) 3-3523-3551
Fax: (81) 3-3523-7581

Touch Technology Division

1 Mitchell Point
Ensign Way
Hamble
Southampton
Hampshire SO31 4RF
United Kingdom
Tel: (44) 23-8056-5600
Fax: (44) 23-8045-3939

Product Contact

Web Site
www.atmel.com

Technical Support
touch@atmel.com

Sales Contact
www.atmel.com/contacts

Literature Requests
www.atmel.com/literature

Disclaimer: The information in this document is provided in connection with Atmel products. No license, express or implied, by estoppel or otherwise, to any intellectual property right is granted by this document or in connection with the sale of Atmel products. **EXCEPT AS SET FORTH IN ATMEL'S TERMS AND CONDITIONS OF SALE LOCATED ON ATMEL'S WEB SITE, ATMEL ASSUMES NO LIABILITY WHATSOEVER AND DISCLAIMS ANY EXPRESS, IMPLIED OR STATUTORY WARRANTY RELATING TO ITS PRODUCTS INCLUDING, BUT NOT LIMITED TO, THE IMPLIED WARRANTY OF MERCHANTABILITY, FITNESS FOR A PARTICULAR PURPOSE, OR NON-INFRINGEMENT. IN NO EVENT SHALL ATMEL BE LIABLE FOR ANY DIRECT, INDIRECT, CONSEQUENTIAL, PUNITIVE, SPECIAL OR INCIDENTAL DAMAGES (INCLUDING, WITHOUT LIMITATION, DAMAGES FOR LOSS OF PROFITS, BUSINESS INTERRUPTION, OR LOSS OF INFORMATION) ARISING OUT OF THE USE OR INABILITY TO USE THIS DOCUMENT, EVEN IF ATMEL HAS BEEN ADVISED OF THE POSSIBILITY OF SUCH DAMAGES.** Atmel makes no representations or warranties with respect to the accuracy or completeness of the contents of this document and reserves the right to make changes to specifications and product descriptions at any time without notice. Atmel does not make any commitment to update the information contained herein. Unless specifically provided otherwise, Atmel products are not suitable for, and shall not be used in, automotive applications. Atmel's products are not intended, authorized, or warranted for use as components in applications intended to support or sustain life.

© 2010 Atmel Corporation. All rights reserved. Atmel®, Atmel logo and combinations thereof, QTouch® and others are registered trademarks, QT™ and others are trademarks of Atmel Corporation or its subsidiaries. Other terms and product names may be registered trademarks or trademarks of others.