



Very Low Noise, 24-Bit Analog-to-Digital Converter

FEATURES

- **24 Bits, No Missing Codes**
 - All Data Rates and PGA Settings
- **Up to 23 Bits Noise-Free Resolution**
- **±0.0010% Nonlinearity (max)**
- **Data Output Rates to 30kSPS**
- **Fast Channel Cycling**
 - 18.6 Bits Noise-Free (21.3 Effective Bits) at 1.45kHz
- **One-Shot Conversions with Single-Cycle Settling**
- **Flexible Input Multiplexer with Sensor Detect**
 - Four Differential Inputs (ADS1256 only)
 - Eight Single-Ended Inputs (ADS1256 only)
- **Chopper-Stabilized Input Buffer**
- **Low-Noise PGA: 27nV Input-Referred Noise**
- **Self and System Calibration for All PGA Settings**
- **5V Tolerant SPI™-Compatible Serial Interface**
- **Analog Supply: 5V**
- **Digital Supply: 1.8V to 3.6V**
- **Power Dissipation**
 - As Low as 38mW in Normal Mode
 - 0.4mW in Standby Mode

DESCRIPTION

The ADS1255 and ADS1256 are extremely low-noise, 24-bit analog-to-digital (A/D) converters. They provide complete high-resolution measurement solutions for the most demanding applications.

The converter is comprised of a 4th-order, delta-sigma ($\Delta\Sigma$) modulator followed by a programmable digital filter. A flexible input multiplexer handles differential or single-ended signals and includes circuitry to verify the integrity of the external sensor connected to the inputs. The selectable input buffer greatly increases the input impedance and the low-noise programmable gain amplifier (PGA) provides gains from 1 to 64 in binary steps. The programmable filter allows the user to optimize between a resolution of up to 23 bits noise-free and a data rate of up to 30k samples per second (SPS). The converters offer fast channel cycling for measuring multiplexed inputs and can also perform one-shot conversions that settle in just a single cycle.

Communication is handled over an SPI-compatible serial interface that can operate with a 2-wire connection. Onboard calibration supports both self and system correction of offset and gain errors for all the PGA settings. Bidirectional digital I/Os and a programmable clock output driver are provided for general use. The ADS1255 is packaged in an SSOP-20, and the ADS1256 in an SSOP-28.

APPLICATIONS

- **Weigh Scales**
- **Scientific Instrumentation**
- **Industrial Process Control**
- **Medical Equipment**
- **Test and Measurement**

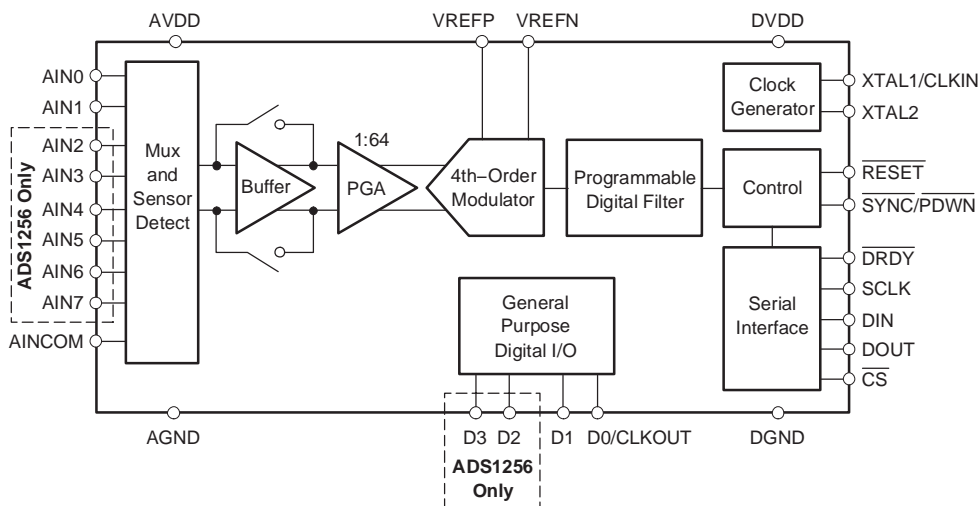

Please be aware that an important notice concerning availability, standard warranty, and use in critical applications of Texas Instruments semiconductor products and disclaimers thereto appears at the end of this data sheet.

All trademarks are the property of their respective owners.

ORDERING INFORMATION(1)

PRODUCT	PACKAGE-LEAD	PACKAGE DESIGNATOR	PACKAGE MARKING	ORDERING NUMBER	TRANSPORT MEDIA, QUANTITY
ADS1255	SSOP-20	DB	ADS1255IDB	ADS1255IDBT	Tape and Reel, 250
				ADS1255IDBR	Tape and Reel, 1000
ADS1256	SSOP-28	DB	ADS1256IDB	ADS1256IDBT	Tape and Reel, 250
				ADS1256IDBR	Tape and Reel, 1000

(1) For the most current package and ordering information, refer to our web site at www.ti.com.

ABSOLUTE MAXIMUM RATINGS

over operating free-air temperature range unless otherwise noted(1)

		ADS1255, ADS1256	UNIT
AVDD to AGND		-0.3 to +6	V
DVDD to DGND		-0.3 to +3.6	V
AGND to DGND		-0.3 to +0.3	V
Input Current		100, Momentary	mA
		10, Continuous	mA
Analog inputs to AGND		-0.3 to AVDD + 0.3	V
Digital inputs	DIN, SCLK, CS, RESET, SYNC/PDWN, XTAL1/CLKIN to DGND	-0.3 to +6	V
	D0/CLKOUT, D1, D2, D3 to DGND	-0.3 to DVDD + 0.3	V
Maximum Junction Temperature		+150	°C
Operating Temperature Range		-40 to +105	°C
Storage Temperature Range		-60 to +150	°C
Lead Temperature (soldering, 10s)		+300	°C

(1) Stresses above those listed under Absolute Maximum Ratings may cause permanent damage to the device. Exposure to absolute maximum conditions for extended periods may degrade device reliability. These are stress ratings only, and functional operation of the device at these or any other conditions beyond those specified is not implied.



This integrated circuit can be damaged by ESD. Texas Instruments recommends that all integrated circuits be handled with appropriate precautions. Failure to observe proper handling and installation procedures can cause damage.

ESD damage can range from subtle performance degradation to complete device failure. Precision integrated circuits may be more susceptible to damage because very small parametric changes could cause the device not to meet its published specifications.

ELECTRICAL CHARACTERISTICS

All specifications at -40°C to $+85^{\circ}\text{C}$, $\text{AVDD} = +5\text{V}$, $\text{DVDD} = +1.8\text{V}$, $f_{\text{CLKIN}} = 7.68\text{MHz}$, $\text{PGA} = 1$, and $\text{V}_{\text{REF}} = +2.5\text{V}$, unless otherwise noted.

PARAMETER	TEST CONDITIONS	MIN	TYP	MAX	UNIT
Analog Inputs					
Full-scale input voltage ($\text{AIN}_P - \text{AIN}_N$)		$\pm 2\text{V}_{\text{REF}}/\text{PGA}$			V
Absolute input voltage (AIN_0-7 , AINCOM to AGND)	Buffer off	$\text{AGND} - 0.1$		$\text{AVDD} + 0.1$	V
	Buffer on	AGND		$\text{AVDD} - 2.0$	V
Programmable gain amplifier		1		64	
Differential input impedance	Buffer off, $\text{PGA} = 1, 2, 4, 8, 16$		$150/\text{PGA}$		$\text{k}\Omega$
	Buffer off, $\text{PGA} = 32, 64$		4.7		$\text{k}\Omega$
	Buffer on, $f_{\text{DATA}} \leq 50\text{Hz}^{(1)}$		80		$\text{M}\Omega$
Sensor detect current sources	$\text{SDCS}[1:0] = 01$		0.5		μA
	$\text{SDCS}[1:0] = 10$		2		μA
	$\text{SDCS}[1:0] = 11$		10		μA
System Performance					
Resolution		24			Bit
No missing codes	All data rates and PGA settings	24			Bit
Data rate (f_{DATA})	$f_{\text{CLKIN}} = 7.68\text{MHz}$	2.5		30,000	$\text{SPS}^{(2)}$
Integral nonlinearity	Differential input, $\text{PGA} = 1$		± 0.0003	± 0.0010	$\%\text{FSR}^{(3)}$
	Differential input, $\text{PGA} = 64$		± 0.0007		$\%\text{FSR}$
Offset error	After calibration	On the level of the noise			
Offset drift	$\text{PGA} = 1$		± 100		$\text{nV}/^{\circ}\text{C}$
	$\text{PGA} = 64$		± 4		$\text{nV}/^{\circ}\text{C}$
Gain error	After calibration, $\text{PGA} = 1$, Buffer on		± 0.005		%
	After calibration, $\text{PGA} = 64$, Buffer on		± 0.03		%
Gain drift	$\text{PGA} = 1$		± 0.8		$\text{ppm}/^{\circ}\text{C}$
	$\text{PGA} = 64$		± 0.8		$\text{ppm}/^{\circ}\text{C}$
Common-mode rejection	$f_{\text{CM}}^{(4)} = 60\text{Hz}$, $f_{\text{DATA}} = 30\text{kSPS}^{(5)}$	95	110		dB
Noise		See Noise Performance Tables			
AVDD power-supply rejection	$\pm 5\% \Delta$ in AVDD	60	70		dB
DVDD power-supply rejection	$\pm 10\% \Delta$ in DVDD		100		dB
Voltage Reference Inputs					
Reference input voltage (V_{REF})	$\text{V}_{\text{REF}} \equiv \text{V}_{\text{REFP}} - \text{V}_{\text{REFN}}$	0.5	2.5	2.6	V
Negative reference input (V_{REFN})	Buffer off	$\text{AGND} - 0.1$		$\text{V}_{\text{REFP}} - 0.5$	V
	Buffer on ⁽⁶⁾	AGND		$\text{V}_{\text{REFP}} - 0.5$	V
Positive reference input (V_{REFP})	Buffer off	$\text{V}_{\text{REFN}} + 0.5$		$\text{AVDD} + 0.1$	V
	Buffer on ⁽⁶⁾	$\text{V}_{\text{REFN}} + 0.5$		$\text{AVDD} - 2.0$	V
Voltage reference impedance	$f_{\text{CLKIN}} = 7.68\text{MHz}$		18.5		$\text{k}\Omega$
Digital Input/Output					
V_{IH}	DIN , SCLK , XTAL1/CLKIN , SYNC/PDWN , CS , RESET	0.8 DVDD		5.25	V
	D0/CLKOUT , D1 , D2 , D3	0.8 DVDD		DVDD	V
V_{IL}		DGND		0.2 DVDD	V
V_{OH}	$\text{I}_{\text{OH}} = 5\text{mA}$	0.8 DVDD			V
V_{OL}	$\text{I}_{\text{OL}} = 5\text{mA}$			0.2 DVDD	V
Input hysteresis		0.5			V
Input leakage	$0 < \text{V}_{\text{DIGITAL INPUT}} < \text{DVDD}$			± 10	μA
Master clock rate	External crystal between XTAL1 and XTAL2	2	7.68	10	MHz
	External oscillator driving CLKIN	0.1	7.68	10	MHz

ELECTRICAL CHARACTERISTICS (continued)

All specifications at -40°C to $+85^{\circ}\text{C}$, AVDD = +5V, DVDD = +1.8V, $f_{\text{CLKIN}} = 7.68\text{MHz}$, PGA = 1, and $V_{\text{REF}} = +2.5\text{V}$, unless otherwise noted.

PARAMETER	TEST CONDITIONS	MIN	TYP	MAX	UNIT
Power-Supply					
AVDD		4.75		5.25	V
DVDD		1.8		3.6	V
AVDD current	Power-down mode			2	μA
	Standby mode		20		μA
	Normal mode, PGA = 1, Buffer off		7	10	mA
	Normal mode, PGA = 64, Buffer off		16	22	mA
	Normal mode, PGA = 1, Buffer on		13	19	mA
	Normal mode, PGA = 64, Buffer on		36	50	mA
DVDD current	Power-down mode			2	μA
	Standby mode, CLKOUT off, DVDD = 3.3V		95		μA
	Normal mode, CLKOUT off, DVDD = 3.3V		0.9	2	mA
Power dissipation	Normal mode, PGA = 1, Buffer off, DVDD = 3.3V		38	57	mW
	Standby mode, DVDD = 3.3V		0.4		mW
Temperature Range					
Specified		-40		+85	$^{\circ}\text{C}$
Operating		-40		+105	$^{\circ}\text{C}$
Storage		-60		+150	$^{\circ}\text{C}$

- (1) See text for more information on input impedance.
- (2) SPS = samples per second.
- (3) FSR = full-scale range = $4V_{\text{REF}}/\text{PGA}$.
- (4) f_{CM} is the frequency of the common-mode input signal.
- (5) Placing a notch of the digital filter at 60Hz (setting $f_{\text{DATA}} = 60\text{SPS}$, 30SPS, 15SPS, 10SPS, 5SPS, or 2.5SPS) will further improve the common-mode rejection of this frequency.
- (6) The reference input range with Buffer on is restricted only if self-calibration or gain self-calibration is to be used. If using system calibration or writing calibration values directly to the registers, the entire Buffer off range can be used.

PIN ASSIGNMENTS

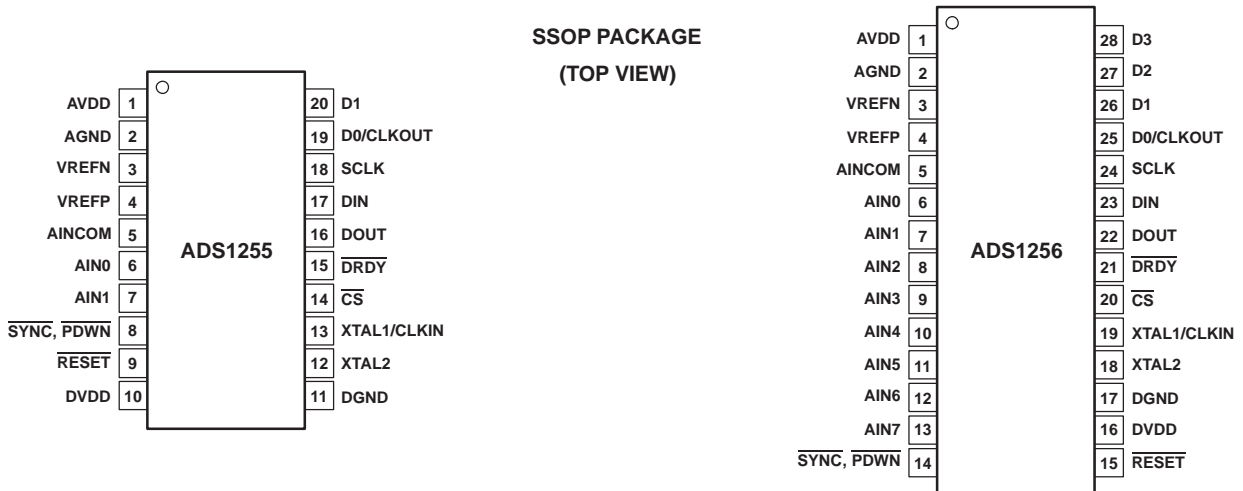

Terminal Functions

NAME	TERMINAL NO.		ANALOG/DIGITAL INPUT/OUTPUT	DESCRIPTION
	ADS1255	ADS1256		
AVDD	1	1	Analog	Analog power supply
AGND	2	2	Analog	Analog ground
VREFN	3	3	Analog input	Negative reference input
VREFP	4	4	Analog input	Positive reference input
AINCOM	5	5	Analog input	Analog input common
AIN0	6	6	Analog input	Analog input 0
AIN1	7	7	Analog input	Analog input 1
AIN2	—	8	Analog input	Analog input 2
AIN3	—	9	Analog input	Analog input 3
AIN4	—	10	Analog input	Analog input 4
AIN5	—	11	Analog input	Analog input 5
AIN6	—	12	Analog input	Analog input 6
AIN7	—	13	Analog input	Analog input 7
SYNC/PDWN	8	14	Digital input ⁽¹⁾⁽²⁾ : active low	Synchronization / power down input
RESET	9	15	Digital input ⁽¹⁾⁽²⁾ : active low	Reset input
DVDD	10	16	Digital	Digital power supply
DGND	11	17	Digital	Digital ground
XTAL2	12	18	Digital ⁽³⁾	Crystal oscillator connection
XTAL1/CLKIN	13	19	Digital/Digital input ⁽²⁾	Crystal oscillator connection / external clock input
CS	14	20	Digital input ⁽¹⁾⁽²⁾ : active low	Chip select
DRDY	15	21	Digital output: active low	Data ready output
DOUT	16	22	Digital output	Serial data output
DIN	17	23	Digital input ⁽¹⁾⁽²⁾	Serial data input
SCLK	18	24	Digital input ⁽¹⁾⁽²⁾	Serial clock input
D0/CLKOUT	19	25	Digital IO ⁽⁴⁾	Digital I/O 0 / clock output
D1	20	26	Digital IO ⁽⁴⁾	Digital I/O 1
D2	—	27	Digital IO ⁽⁴⁾	Digital I/O 2
D3	—	28	Digital IO ⁽⁴⁾	Digital I/O 3

(1) Schmitt-Trigger digital input.

(2) 5V tolerant digital input.

(3) Leave disconnected if external clock input is applied to XTAL1/CLKIN.

(4) Schmitt-Trigger digital input when the digital I/O is configured as an input.

PARAMETER MEASUREMENT INFORMATION

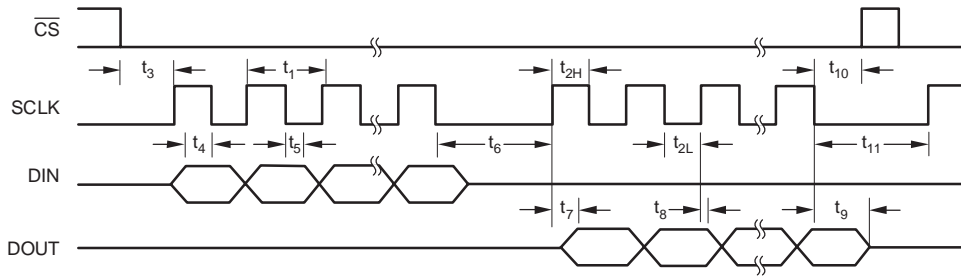

Figure 1. Serial Interface Timing

TIMING CHARACTERISTICS FOR FIGURE 1

SYMBOL	DESCRIPTION	MIN	MAX	UNIT
t ₁	SCLK period	4		$\tau_{CLKIN}^{(1)}$
			10	$\tau_{DATA}^{(2)}$
t _{2H}	SCLK pulse width: high	200		ns
t _{2L}	SCLK pulse width: low		9	τ_{DATA}
t _{2L}	SCLK pulse width: low	200		ns
t ₃	\overline{CS} low to first SCLK: setup time ⁽³⁾	0		ns
t ₄	Valid DIN to SCLK falling edge: setup time	50		ns
t ₅	Valid DIN to SCLK falling edge: hold time	50		ns
t ₆	Delay from last SCLK edge for DIN to first SCLK rising edge for DOUT: RDATA, RDATA \overline{C} , RREG Commands	50		τ_{CLKIN}
t ₇	SCLK rising edge to valid new DOUT: propagation delay ⁽⁴⁾		50	ns
t ₈	SCLK rising edge to DOUT invalid: hold time	0		ns
t ₉	Last SCLK falling edge to DOUT high impedance NOTE: DOUT goes high impedance immediately when \overline{CS} goes high	6	10	τ_{CLKIN}
t ₁₀	\overline{CS} low after final SCLK falling edge	0		ns
t ₁₁	Final SCLK falling edge of command to first SCLK rising edge of next command.	RREG, WREG, RDATA	4	τ_{CLKIN}
		RDATA \overline{C} , RESET, SYNC	24	τ_{CLKIN}
		RDATA \overline{C} , STANDBY, SELF \overline{O} CAL, SY- SOCAL, SELF \overline{G} CAL, SYSG \overline{C} AL, SELF \overline{C} AL	Wait for \overline{DRDY} to go low	

(1) τ_{CLKIN} = master clock period = $1/f_{CLKIN}$.

(2) τ_{DATA} = output data period $1/f_{DATA}$.

(3) \overline{CS} can be tied low.

(4) DOUT load = 20pF || 100k Ω to DGND.

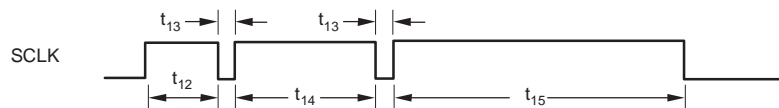

Figure 2. SCLK Reset Timing

TIMING CHARACTERISTICS FOR FIGURE 2

SYMBOL	DESCRIPTION	MIN	MAX	UNIT
t ₁₂	SCLK reset pattern, first high pulse	300	500	τ _{CLKIN} ⁽¹⁾
t ₁₃	SCLK reset pattern, low pulse	5		τ _{CLKIN}
t ₁₄	SCLK reset pattern, second high pulse	550	750	τ _{CLKIN}
t ₁₅	SCLK reset pattern, third high pulse	1050	1250	τ _{CLKIN}

(1) τ_{CLKIN} = master clock period = 1/f_{CLKIN}.



Figure 3. RESET and SYNC/PDWN Timing

TIMING CHARACTERISTICS FOR FIGURE 3

SYMBOL	DESCRIPTION	MIN	MAX	UNIT
t ₁₆	RESET, SYNC/PDWN, pulse width	4		τ _{CLKIN} ⁽¹⁾

(1) τ_{CLKIN} = master clock period = 1/f_{CLKIN}.



Figure 4. DRDY Update Timing

TIMING CHARACTERISTICS FOR FIGURE 4

SYMBOL	DESCRIPTION	MIN	MAX	UNIT
t ₁₇	Conversion data invalid while being updated (DRDY shown with no data retrieval)	16		τ _{CLKIN} ⁽¹⁾

(1) τ_{CLKIN} = master clock period = 1/f_{CLKIN}.

TYPICAL CHARACTERISTICS

$T_A = +25^\circ\text{C}$, $AV_{DD} = 5\text{V}$, $DV_{DD} = 1.8\text{V}$, $f_{CLKIN} = 7.68\text{MHz}$, $PGA = 1$, and $V_{REF} = 2.5\text{V}$, unless otherwise noted.

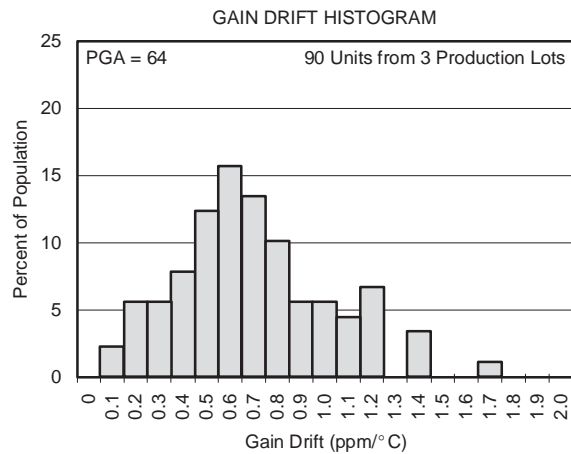
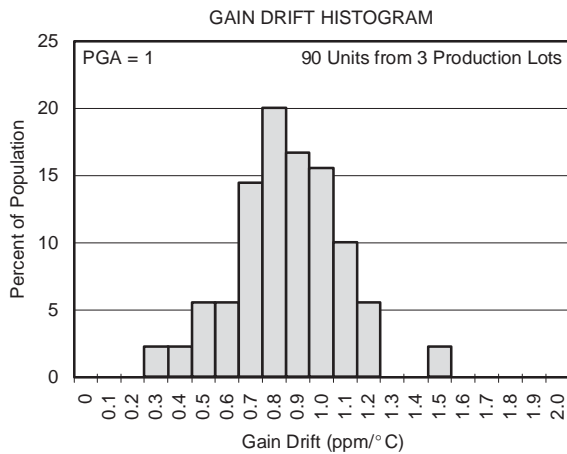
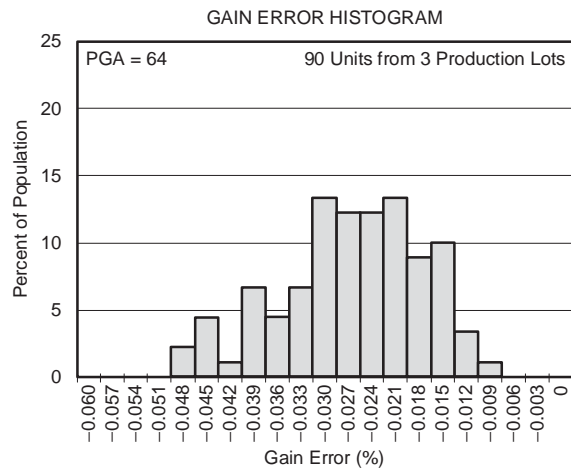
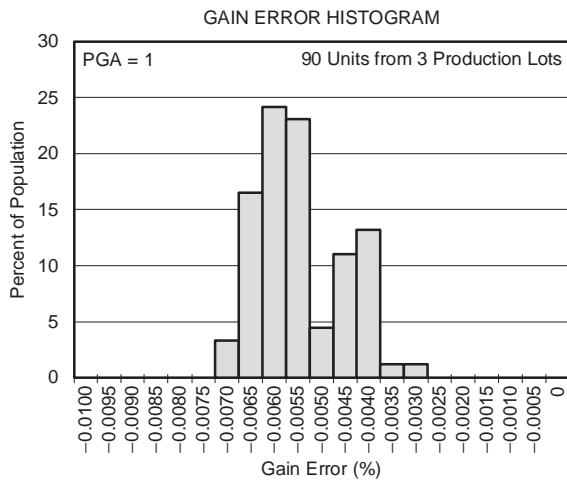
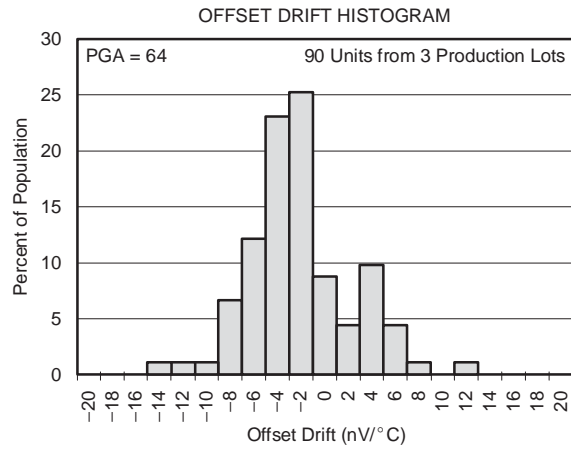
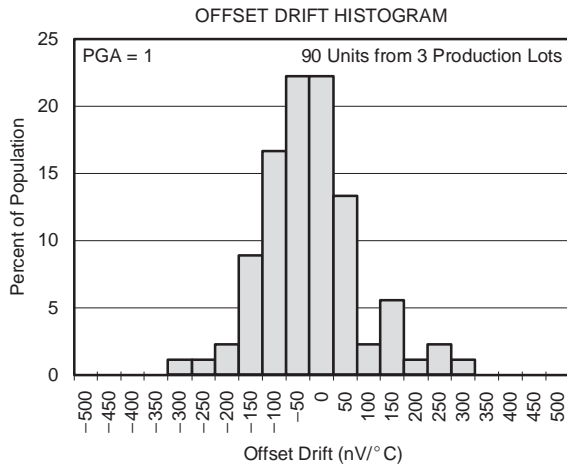

TYPICAL CHARACTERISTICS (continued)

$T_A = +25^\circ\text{C}$, $AV_{DD} = 5\text{V}$, $DV_{DD} = 1.8\text{V}$, $f_{CLKIN} = 7.68\text{MHz}$, $PGA = 1$, and $V_{REF} = 2.5\text{V}$, unless otherwise noted.

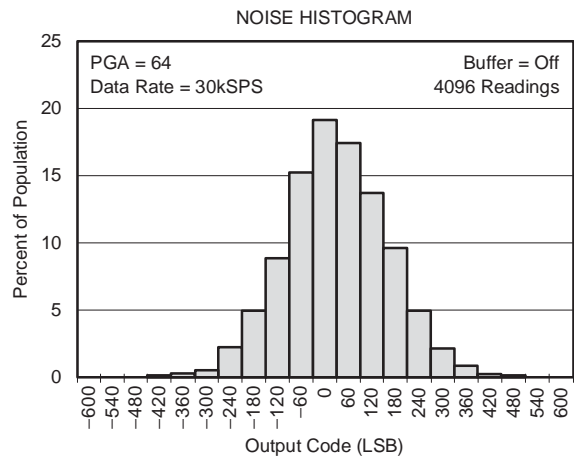
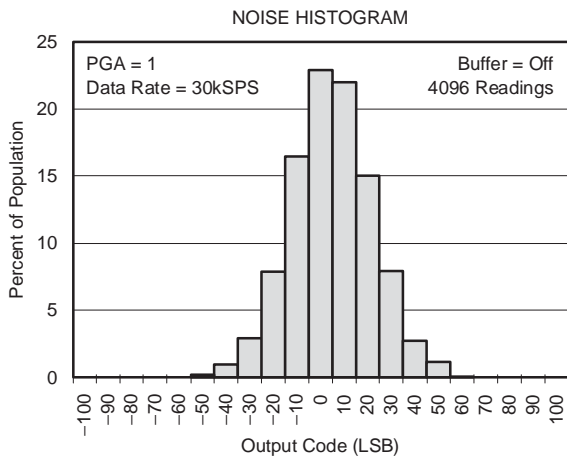
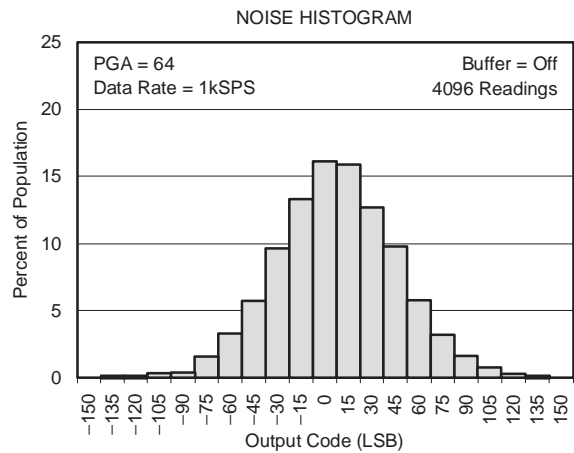
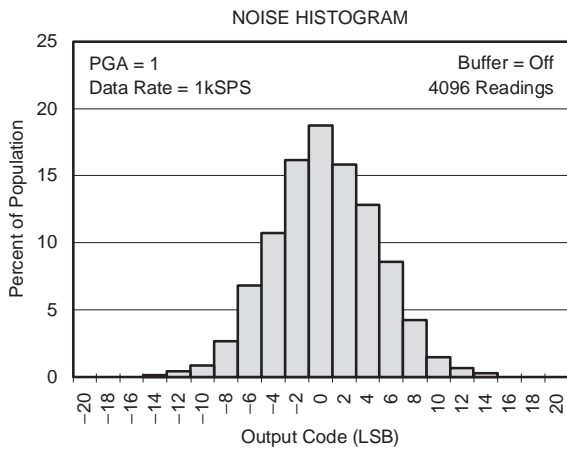
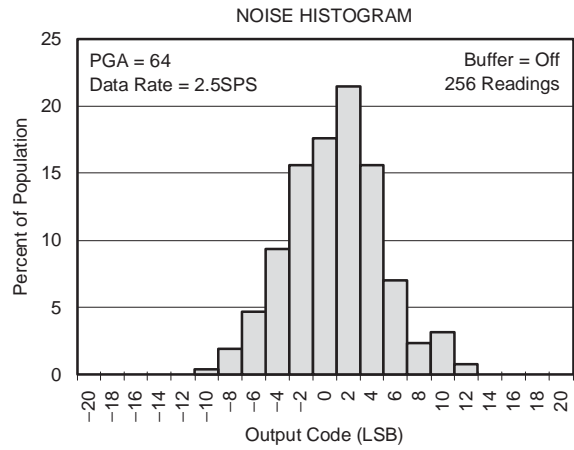
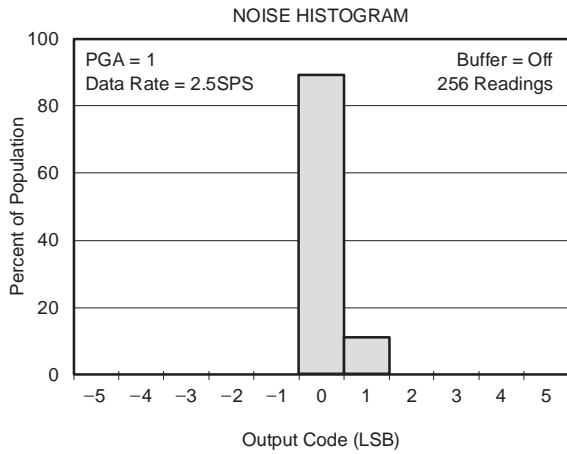

TYPICAL CHARACTERISTICS (continued)

$T_A = +25^\circ\text{C}$, $AV_{DD} = 5\text{V}$, $DV_{DD} = 1.8\text{V}$, $f_{CLKIN} = 7.68\text{MHz}$, $\text{PGA} = 1$, and $V_{REF} = 2.5\text{V}$, unless otherwise noted.

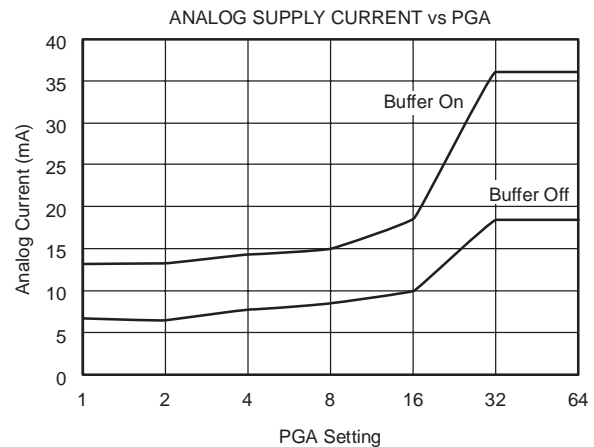
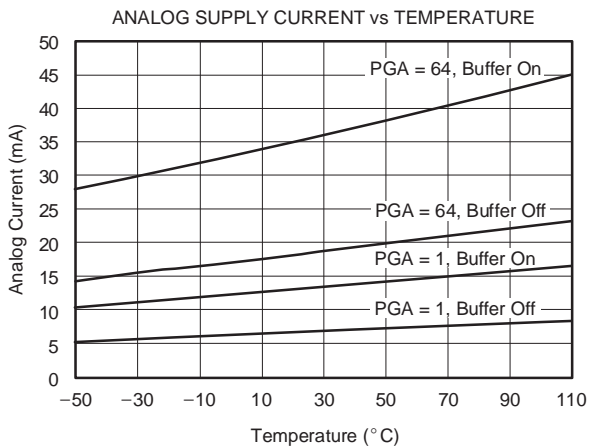
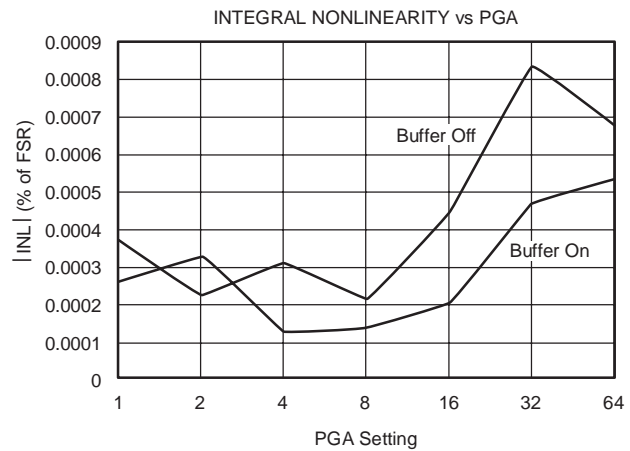
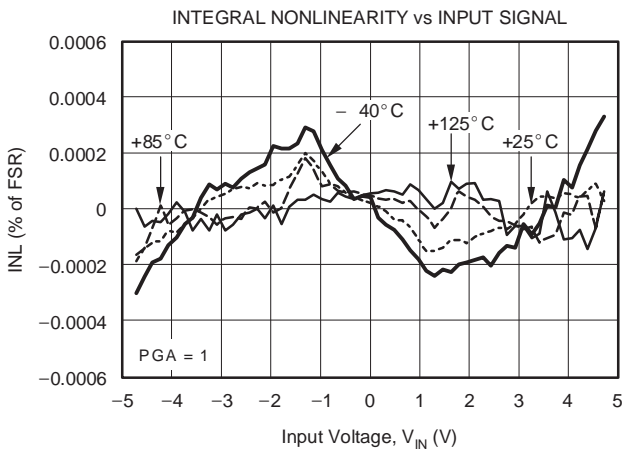
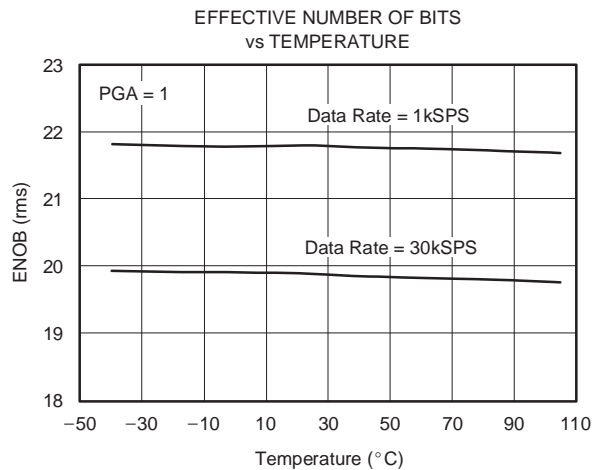
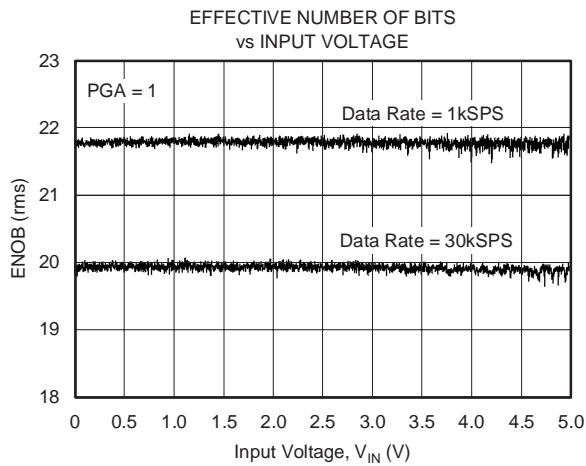

OVERVIEW

The ADS1255 and ADS1256 are very low-noise A/D converters. The ADS1255 supports one differential or two single-ended inputs and has two general-purpose digital I/Os. The ADS1256 supports four differential or eight single-ended inputs and has four general-purpose digital I/Os. Otherwise, the two units are identical and are referred to together in this data sheet as the ADS1255/6.

Figure 5 shows a block diagram of the ADS1256. The input multiplexer selects which input pins are connected to the A/D converter. Selectable current sources within the input multiplexer can check for open- or short-circuit conditions on the external sensor. A selectable onboard input buffer greatly reduces the input circuitry loading by providing up to 80MΩ of impedance. A low-noise PGA provides a gain of 1, 2, 4, 8, 16, 32, or 64. The ADS1255/6 converter is comprised of a 4th-order, delta-sigma modulator followed by a programmable digital filter.

The modulator measures the amplified differential input signal, $V_{IN} = (AIN_P - AIN_N)$, against the differential reference, $V_{REF} = (VREFP - VREFN)$. The differential reference is scaled internally by a factor of two so that the full-scale input range is $\pm 2V_{REF}$ (for PGA = 1).

The digital filter receives the modulator signal and provides a low-noise digital output. The data rate of the filter is programmable from 2.5SPS to 30kSPS and allows tradeoffs between resolution and speed.

Communication is done over an SPI-compatible serial interface with a set of simple commands providing control of the ADS1255/6. Onboard registers store the various settings for the input multiplexer, sensor detect current sources, input buffer enable, PGA setting, data rate, etc. Either an external crystal or clock oscillator can be used to provide the clock source. General-purpose digital I/Os provide static read/write control of up to four pins. One of the pins can also be used to supply a programmable clock output.

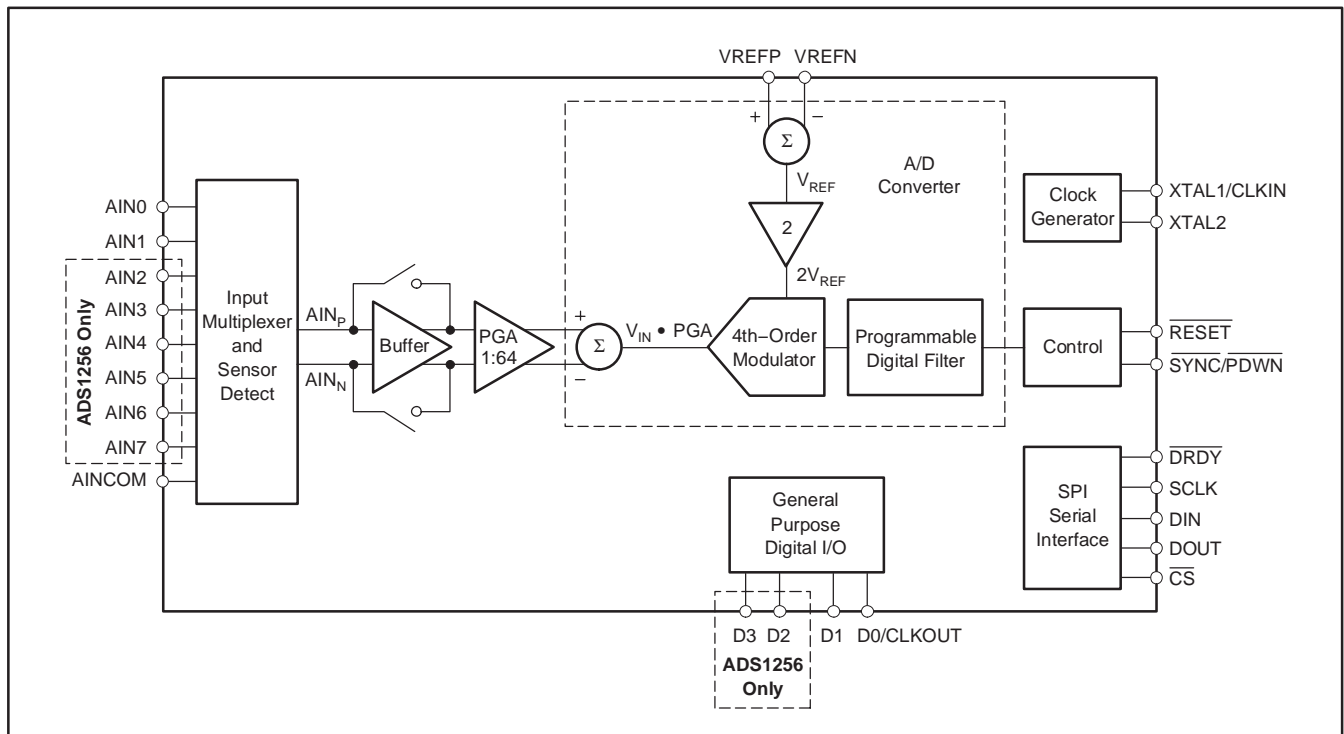

Figure 5. Block Diagram

NOISE PERFORMANCE

The ADS1255/6 offer outstanding noise performance that can be optimized by adjusting the data rate or PGA setting. As the averaging is increased by reducing the data rate, the noise drops correspondingly. The PGA reduces the input-referred noise when measuring lower level signals. Table 1 through Table 6 summarize the typical noise performance with the inputs shorted externally. In all six tables, the following conditions apply: T = +25°C, AVDD = 5V, DVDD = 1.8V, VREF = 2.5V, and f_{CLKIN} = 7.68MHz. Table 1 to Table 3 reflect the device input buffer enabled. Table 1 shows the rms value of the input-referred noise in volts. Table 2 shows the effective number of bits of resolution (ENOB), using the noise data from Table 1. ENOB is defined as:

$$\text{ENOB} = \frac{\ln(\text{FSR}/\text{RMS Noise})}{\ln(2)}$$

where FSR is the full-scale range. Table 3 shows the noise-free bits of resolution. It is calculated with the same formula as ENOB except the peak-to-peak noise value is used instead of rms noise. Table 4 through Table 6 show the same noise data, but with the input buffer disabled.

Table 1. Input Referred Noise (μV, rms) with Buffer On

DATA RATE (SPS)	PGA						
	1	2	4	8	16	32	64
2.5	0.247	0.156	0.080	0.056	0.043	0.037	0.033
5	0.301	0.175	0.102	0.076	0.061	0.045	0.044
10	0.339	0.214	0.138	0.106	0.082	0.061	0.061
15	0.401	0.264	0.169	0.126	0.107	0.085	0.073
25	0.494	0.305	0.224	0.149	0.134	0.102	0.093
30	0.533	0.335	0.245	0.176	0.138	0.104	0.106
50	0.629	0.393	0.292	0.216	0.168	0.136	0.122
60	0.692	0.438	0.321	0.233	0.184	0.146	0.131
100	0.875	0.589	0.409	0.305	0.229	0.170	0.169
500	1.946	1.250	0.630	0.648	0.497	0.390	0.367
1000	2.931	1.891	1.325	1.070	0.689	0.512	0.486
2000	4.173	2.589	1.827	1.492	0.943	0.692	0.654
3750	5.394	3.460	2.376	1.865	1.224	0.912	0.906
7500	7.249	4.593	3.149	2.436	1.691	1.234	1.187
15,000	9.074	5.921	3.961	2.984	2.125	1.517	1.515
30,000	10.728	6.705	4.446	3.280	2.416	1.785	1.742

Table 2. Effective Number of Bits (ENOB, rms) with Buffer On

DATA RATE (SPS)	PGA						
	1	2	4	8	16	32	64
2.5	25.3	24.9	24.9	24.4	23.8	23.0	22.2
5	25.0	24.8	24.5	24.0	23.3	22.7	21.8
10	24.8	24.5	24.1	23.5	22.9	22.3	21.3
15	24.6	24.2	23.8	23.2	22.5	21.8	21.0
25	24.3	24.0	23.4	23.0	22.2	21.5	20.7
30	24.2	23.8	23.3	22.8	22.1	21.5	20.5
50	23.9	23.6	23.0	22.5	21.8	21.1	20.3
60	23.8	23.4	22.9	22.4	21.7	21.0	20.2
100	23.4	23.0	22.5	22.0	21.4	20.8	19.8
500	22.3	21.9	21.5	20.9	20.3	19.6	18.7
1000	21.7	21.3	20.8	20.2	19.8	19.2	18.3
2000	21.2	20.9	20.4	19.7	19.3	18.8	17.9
3750	20.8	20.5	20.0	19.4	19.0	18.4	17.4
7500	20.4	20.1	19.6	19.0	18.5	17.9	17.0
15,000	20.1	19.7	19.3	18.7	18.2	17.7	16.7
30,000	19.8	19.5	19.1	18.5	18.0	17.4	16.5

Table 3. Noise-Free Resolution (bits) with Buffer On

DATA RATE (SPS)	PGA						
	1	2	4	8	16	32	64
2.5	23.0	22.6	22.1	21.7	21.3	20.8	19.7
5	22.3	22.4	21.9	21.3	20.7	20.3	19.3
10	22.3	22.0	21.6	21.0	20.4	19.9	18.9
15	22.0	21.7	21.3	20.7	20.1	19.3	18.7
25	21.7	21.4	21.1	20.5	19.7	19.2	18.5
30	21.8	21.3	20.8	20.4	19.8	19.0	18.1
50	21.3	21.1	20.4	19.9	19.4	18.8	17.9
60	21.3	20.9	20.5	19.8	19.3	18.8	17.8
100	20.9	20.7	20.2	19.6	19.1	18.5	17.4
500	20.1	19.6	19.1	18.6	18.0	17.3	16.3
1000	19.0	18.6	18.1	17.5	17.2	16.5	15.6
2000	18.5	18.1	17.8	17.0	16.6	16.1	15.3
3750	18.1	17.8	17.3	16.6	16.2	15.7	14.7
7500	17.7	17.3	16.9	16.2	15.8	15.3	14.4
15,000	17.3	17.0	16.5	15.9	15.5	14.9	13.9
30,000	17.1	16.7	16.4	15.9	15.4	14.6	13.8

Table 4. Input Referred Noise (μV , rms) with Buffer Off

DATA RATE (SPS)	PGA						
	1	2	4	8	16	32	64
2.5	0.247	0.149	0.097	0.058	0.036	0.031	0.027
5	0.275	0.176	0.109	0.070	0.046	0.039	0.038
10	0.338	0.201	0.129	0.084	0.063	0.048	0.047
15	0.401	0.221	0.150	0.109	0.070	0.063	0.057
25	0.485	0.279	0.177	0.136	0.093	0.076	0.076
30	0.559	0.315	0.202	0.142	0.107	0.093	0.082
50	0.644	0.390	0.238	0.187	0.129	0.108	0.103
60	0.688	0.417	0.281	0.204	0.134	0.109	0.111
100	0.815	0.530	0.360	0.233	0.169	0.123	0.122
500	1.957	1.148	0.772	0.531	0.375	0.276	0.259
1000	2.803	1.797	1.191	0.940	0.518	0.392	0.365
2000	4.025	2.444	1.615	1.310	0.700	0.526	0.461
3750	5.413	3.250	2.061	1.578	0.914	0.693	0.625
7500	7.017	4.143	2.722	1.998	1.241	0.914	0.857
15,000	8.862	5.432	3.378	2.411	1.569	1.149	1.051
30,000	10.341	6.137	3.873	2.775	1.805	1.313	1.211

Table 6. Noise-Free Resolution (bits) with Buffer Off

DATA RATE (SPS)	PGA						
	1	2	4	8	16	32	64
2.5	23.0	22.4	22.0	21.9	21.3	21.1	20.0
5	22.4	22.1	21.9	21.5	21.2	20.4	19.4
10	22.3	22.1	21.7	21.5	20.8	20.3	19.2
15	22.0	21.8	21.4	20.8	20.6	19.9	19.0
25	21.8	21.7	21.1	20.7	20.3	19.5	18.6
30	21.6	21.4	21.1	20.4	20.0	16.4	18.5
50	21.3	21.3	20.7	20.1	19.8	19.1	18.2
60	21.2	21.0	20.6	20.1	19.8	19.1	18.1
100	21.1	20.5	20.3	19.9	19.5	19.0	17.9
500	20.0	19.7	19.3	18.9	18.3	17.8	16.9
1000	19.0	18.7	18.4	17.7	17.5	16.9	15.9
2000	18.5	18.3	17.9	17.4	17.0	16.4	15.6
3750	18.1	17.8	17.5	17.0	16.7	16.1	15.2
7500	17.7	17.6	17.0	16.6	16.2	15.7	14.8
15,000	17.4	17.1	16.8	16.3	15.9	15.3	14.4
30,000	17.1	17.0	16.6	16.0	15.6	15.0	14.4

Table 5. Effective Number of Bits (ENOB, rms) with Buffer Off

DATA RATE (SPS)	PGA						
	1	2	4	8	16	32	64
2.5	25.3	25.0	24.6	24.4	24.0	23.2	22.5
5	25.1	24.8	24.5	24.1	23.7	22.9	22.0
10	24.8	24.6	24.2	23.8	23.2	22.6	21.7
15	24.6	24.4	24.0	23.4	23.1	22.2	21.4
25	24.3	24.1	23.8	23.1	22.7	22.0	21.0
30	24.1	23.9	23.6	23.1	22.5	21.7	20.9
50	23.9	23.6	23.3	22.7	22.2	21.5	20.5
60	23.8	23.5	23.1	22.5	22.1	21.5	20.4
100	23.5	23.2	22.7	22.4	21.8	21.3	20.3
500	22.3	22.1	21.6	21.2	20.7	20.1	19.2
1000	21.8	21.4	21.0	20.3	20.2	19.6	18.7
2000	21.2	21.0	20.6	19.9	19.8	19.2	18.4
3750	20.8	20.6	20.2	19.6	19.4	18.8	17.9
7500	20.4	20.2	19.8	19.3	18.9	18.4	17.5
15,000	20.1	19.8	19.5	19.0	18.6	18.1	17.2
30,000	19.9	19.6	19.3	18.8	18.4	17.9	17.0

INPUT MULTIPLEXER

Figure 6 shows a simplified diagram of the input multiplexer. This flexible block allows any analog input pin to be connected to either of the converter differential inputs. That is, any pin can be selected as the positive input (AIN_P); likewise, any pin can be selected as the negative input (AIN_N). The pin selection is controlled by the multiplexer register.

The ADS1256 offers nine analog inputs, which can be configured as four independent differential inputs, eight single-ended inputs, or a combination of differential and single-ended inputs.

The ADS1255 offers three analog inputs, which can be configured as one differential input or two single-ended inputs. When using the ADS1255 and programming the input, make sure to select only the available inputs when programming the input multiplexer register.

In general, there are no restrictions on input pin selection.

However, for optimum analog performance, the following recommendations are made:

1. For differential measurements use AIN0 through AIN7, preferably adjacent inputs. For example, use AIN0 and AIN1. Do not use AINCOM.
2. For single-ended measurements use AINCOM as common input and AIN0 through AIN7 as single-ended inputs.
3. Leave any unused analog inputs floating. This minimizes the input leakage current.

ESD diodes protect the analog inputs. To keep these diodes from turning on, make sure the voltages on the input pins do not go below AGND by more than 100mV, and likewise do not exceed AVDD by more than 100mV: $-100\text{mV} < (\text{AIN}0 - 7 \text{ and } \text{AINCOM}) < \text{AVDD} + 100\text{mV}$.

When using ADS1255/6 for single-ended measurements, it is important to note that common input AINCOM does not need to be tied to ground. For example, AINCOM can be tied to a midpoint reference such as +2.5V or even AVDD.

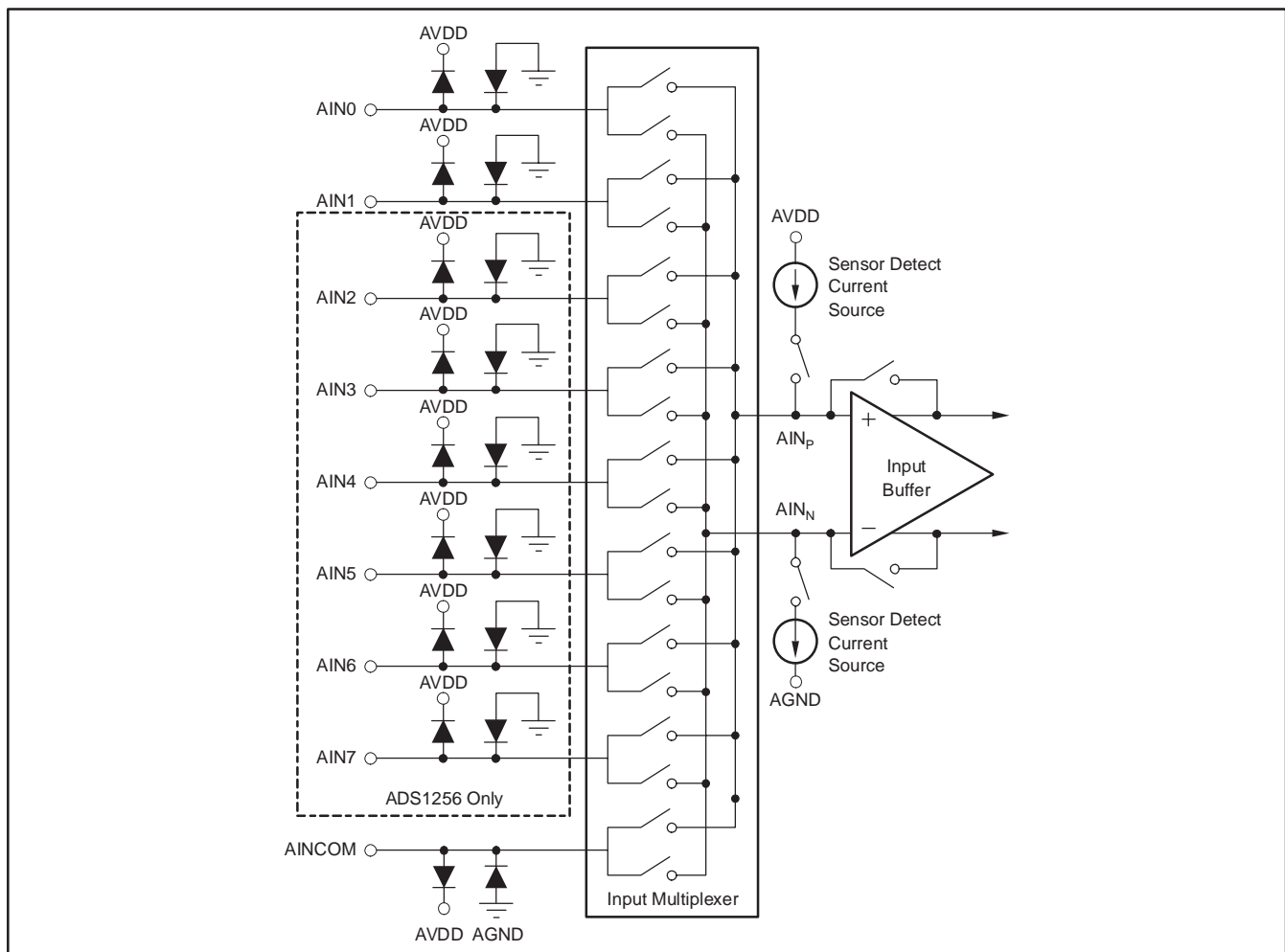

Figure 6. Simplified Diagram of the Input Multiplexer

OPEN/SHORT SENSOR DETECTION

The sensor detect current sources (SDCS) provide a means to verify the integrity of the external sensor connected to the ADS1255/6. When enabled, the SDCS supply a current (I_{SDC}) of approximately 0.5 μ A, 2 μ A, or 10 μ A to the sensor through the input multiplexer. The SDCS bits in the ADCON register enable the SDCS and set the value of I_{SDC} .

When the SDCS are enabled, the ADS1255/6 automatically turns on the analog input buffer regardless of the BUFEN bit setting. This is done to prevent the input circuitry from loading the SDCS. AIN_P must stay below 3V to be within the absolute input range of the buffer. To ensure this condition is met, a 3V clamp will start sinking current from AIN_P to AGND if AIN_P exceeds 3V. Note that this clamp is activated only when the SDCS are enabled.

Figure 7 shows a simplified diagram of ADS1255/6 input structure with the external sensor modeled as resistance R_{SENS} between two input pins. When the SDCS are enabled, they source I_{SDC} to the input pin connected to AIN_P and sink I_{SDC} from the input pin connected to AIN_N . The two 25 Ω series resistors, R_{MUX} , model the ADS1255/6 internal resistances. The signal measured with the SDCS enabled equals the total IR drop: $I_{SDC} \times (2R_{MUX} + R_{SENS})$. Note that when the sensor is a direct short (that is, $R_{SENS} = 0$), there will still be a small signal measured by the ADS1255/6 when the SDCS are enabled: $I_{SDC} \times 2R_{MUX}$.

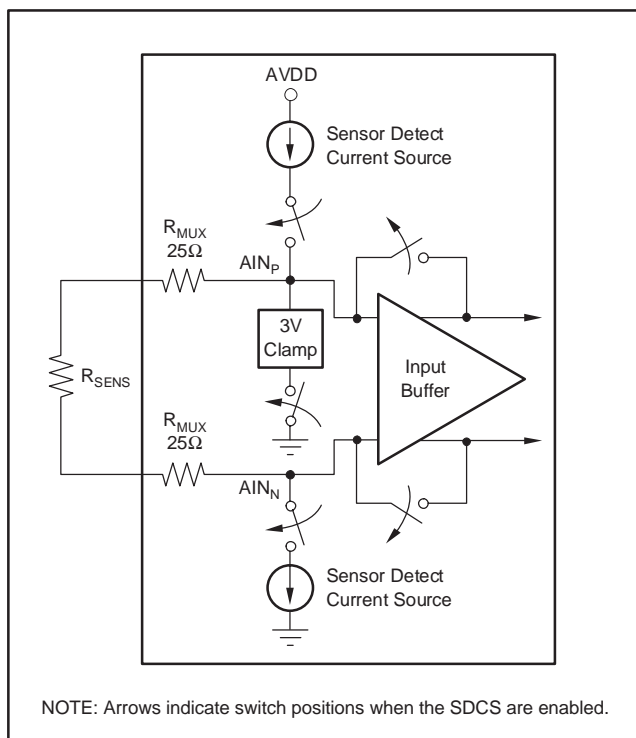

Figure 7. Sensor Detect Circuitry

ANALOG INPUT BUFFER

To dramatically increase the input impedance presented by the ADS1255/6, the low-drift chopper-stabilized buffer can be enabled via the BUFEN bit in the STATUS register. The input impedance with the buffer enabled can be modeled by a resistor, as shown in Figure 8. Table 7 lists the values of Z_{EFF} for the different data rate settings. The input impedance scales inversely with the frequency of CLKIN. For example, if f_{CLKIN} is reduced by half to 3.84MHz, Z_{EFF} for a data rate of 50SPS will double from 80M Ω to 160M Ω .

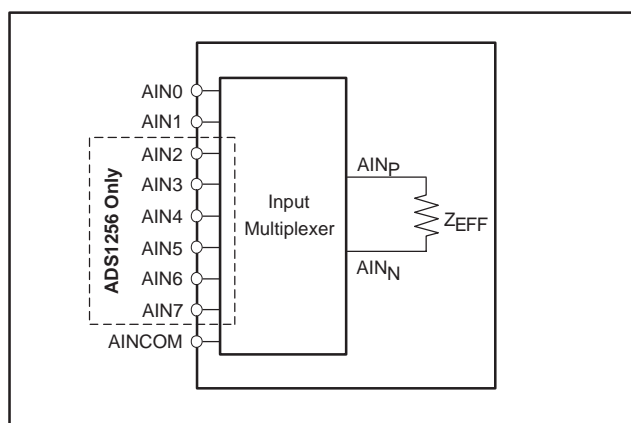

Figure 8. Effective Impedance with Buffer On

Table 7. Input Impedance with Buffer On

DATA RATE (SPS)	Z_{EFF} (M Ω)
30,000	10
15,000	10
7,500	10
3,750	10
2,000	10
1,000	20
500	40
100	40
60	40
≤ 50	80

NOTE: $f_{CLKIN} = 7.68$ MHz.

With the buffer enabled, the voltage on the analog inputs with respect to ground (listed in the Electrical Characteristics as *Absolute Input Voltage*) must remain between AGND and $AVDD - 2.0V$. Exceeding this range reduces performance, in particular the linearity of the ADS1255/6. This same voltage range, AGND to $AVDD - 2.0V$, applies to the reference inputs when performing a self gain calibration with the buffer enabled.

PROGRAMMABLE GAIN AMPLIFIER (PGA)

The ADS1255/6 is a very high resolution converter. To further complement its performance, the low-noise PGA provides even more resolution when measuring smaller input signals. For the best resolution, set the PGA to the highest possible setting. This will depend on the largest input signal to be measured. The ADS1255/6 full-scale input voltage equals $\pm 2V_{REF}/PGA$. Table 8 shows the full-scale input voltage for the different PGA settings for $V_{REF} = 2.5V$. For example, if the largest signal to be measured is 1.0V, the optimum PGA setting would be 4, which gives a full-scale input voltage of 1.25V. Higher PGAs cannot be used since they cannot handle a 1.0V input signal.

Table 8. Full-Scale Input Voltage vs PGA Setting

PGA SETTING	FULL-SCALE INPUT VOLTAGE ($V_{REF} = 2.5V$)
1	$\pm 5V$
2	$\pm 2.5V$
4	$\pm 1.25V$
8	$\pm 0.625V$
16	$\pm 312.5mV$
32	$\pm 156.25mV$
64	$\pm 78.125mV$

The PGA is controlled by the ADCON register. Recalibrating the A/D converter after changing the PGA setting is recommended. The time required for self-calibration is dependent on the PGA setting. See the Calibration section for more details. The analog current and input impedance (when the buffer is disabled) vary as a function of PGA setting.

MODULATOR INPUT CIRCUITRY

The ADS1255/6 modulator measures the input signal using internal capacitors that are continuously charged and discharged. Figure 9 shows a simplified schematic of the ADS1255/6 input circuitry with the input buffer disabled. Figure 10 shows the on/off timings of the switches of Figure 9. S1 switches close during the input sampling phase. With S1 closed, C_{A1} charges to A_{INP} , C_{A2} charges to A_{INN} , and C_B charges to $(A_{INP} - A_{INN})$. For the discharge phase, S1 opens first and then S2 closes. C_{A1} and C_{A2} discharge to approximately $AVDD/2$ and C_B discharges to 0V. This two-phase sample/discharge cycle

repeats with a period of τ_{SAMPLE} . This time is a function of the PGA setting as shown in Table 9 along with the values of the capacitor $C_{A1} = C_{A2} = C_A$ and C_B .

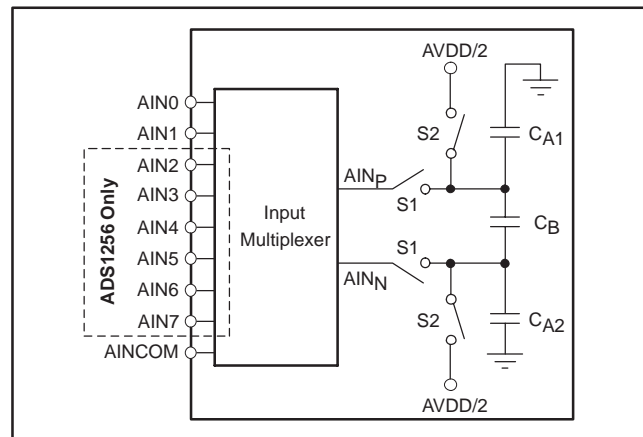

Figure 9. Simplified Input Structure with Buffer Off

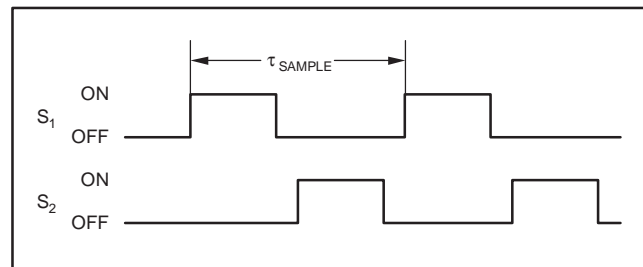

Figure 10. S1 and S2 Switch Timing for Figure 9

Table 9. Input Sampling Time, τ_{SAMPLE} , and C_A and C_B vs PGA

PGA SETTING	$\tau_{SAMPLE}^{(1)}$	C_A	C_B
1	$f_{CLKIN}/4$ (521ns)	2.1pF	2.4pF
2	$f_{CLKIN}/4$ (521ns)	4.2pF	4.9pF
4	$f_{CLKIN}/4$ (521ns)	8.3pF	9.7pF
8	$f_{CLKIN}/4$ (521ns)	17pF	19pF
16	$f_{CLKIN}/4$ (521ns)	33pF	39pF
32	$f_{CLKIN}/2$ (260ns)	33pF	39pF
64	$f_{CLKIN}/2$ (260ns)	33pF	39pF

⁽¹⁾ τ_{SAMPLE} for $f_{CLKIN} = 7.68MHz$.

The charging of the input capacitors draws a transient current from the sensor driving the ADS1255/6 inputs. The average value of this current can be used to calculate an effective impedance Z_{EFF} where $Z_{EFF} = V_{IN} / I_{AVERAGE}$. Figure 11 shows the input circuitry with the capacitors and switches of Figure 9 replaced by their effective impedances. These impedances scale inversely with the CLKIN frequency. For example, if f_{CLKIN} is reduced by a factor of two, the impedances will double. They also change with the PGA setting. Table 10 lists the effective impedances with the buffer off for $f_{CLKIN} = 7.68\text{MHz}$.

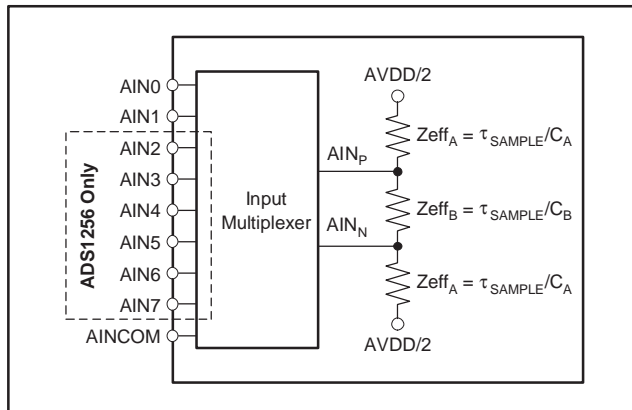

Figure 11. Analog Input Effective Impedances with Buffer Off

Table 10. Analog Input Impedances with Buffer Off

PGA SETTING	ZeffA (kΩ)	ZeffB (kΩ)
1	260	220
2	130	110
4	65	55
8	33	28
16	16	14
32	8	7
64	8	7

NOTE: $f_{CLKIN} = 7.68\text{MHz}$.

VOLTAGE REFERENCE INPUTS (VREFP, VREFN)

The voltage reference for the ADS1255/6 A/D converter is the differential voltage between VREFP and VREFN: $V_{REF} = V_{REFP} - V_{REFN}$. The reference inputs use a structure similar to that of the analog inputs with the circuitry on the reference inputs of Figure 12. The load presented by the switched capacitor can be modeled with an effective impedance (Z_{EFF}) of $18.5\text{k}\Omega$ for $f_{CLKIN} = 7.68\text{MHz}$. The temperature coefficient of the effective impedance of the voltage reference inputs is approximately $35\text{ppm}/^\circ\text{C}$.

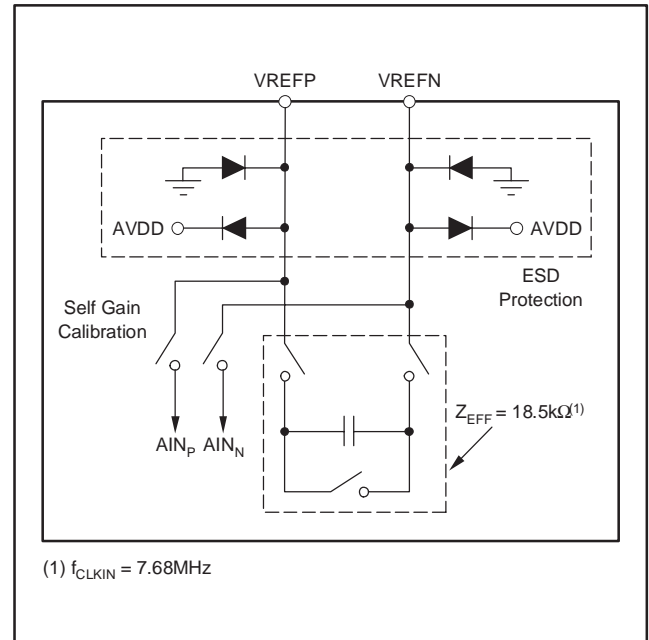

Figure 12. Simplified Reference Input Circuitry

ESD diodes protect the reference inputs. To keep these diodes from turning on, make sure the voltages on the reference pins do not go below AGND by more than 100mV , and likewise do not exceed AVDD by 100mV :

$$-100\text{mV} < (V_{REFP} \text{ or } V_{REFN}) < AVDD + 100\text{mV}$$

During self gain calibration, all the switches in the input multiplexer are opened, VREFN is internally connected to AINn, and VREFP is connected to AINp. The input buffer may be disabled or enabled during calibration. When the buffer is disabled, the reference pins will be driving the circuitry shown in Figure 9 during self gain calibration, resulting in increased loading. To prevent this additional loading from introducing gain errors, make sure the circuitry driving the reference pins has adequate drive capability. When the buffer is enabled, the loading on the reference pins will be much less, but the buffer will limit the allowable voltage range on VREFP and VREFN during self or self gain calibration as the reference pins must remain within the specified input range of the buffer in order to establish proper gain calibration.

A high-quality reference voltage is essential for achieving the best performance from the ADS1255/6. Noise and drift on the reference degrade overall system performance. It is especially critical that special care be given to the circuitry generating the reference voltages and their layout when operating in the low-noise settings (that is, with low data rates) to prevent the voltage reference from limiting performance.

DIGITAL FILTER

The programmable low-pass digital filter receives the modulator output and produces a high-resolution digital output. By adjusting the amount of filtering, tradeoffs can be made between resolution and data rate: filter more for higher resolution, filter less for higher data rate. The filter is comprised of two sections, a fixed filter followed by a programmable filter. Figure 13 shows the block diagram of the analog modulator and digital filter. Data is supplied to the filter from the analog modulator at a rate of $f_{CLKIN}/4$. The fixed filter is a 5th-order sinc filter with a decimation value of 64 that outputs data at a rate of $f_{CLKIN}/256$. The second stage of the filter is a programmable averager (1st-order sinc filter) with the number of averages set by the DRATE register. The data rate is a function of the number of averages (Num_Ave) and is given by Equation 1.

$$\text{Data Rate} = \left(\frac{f_{CLKIN}}{256} \right) \left(\frac{1}{\text{Num_Ave}} \right) \quad (1)$$

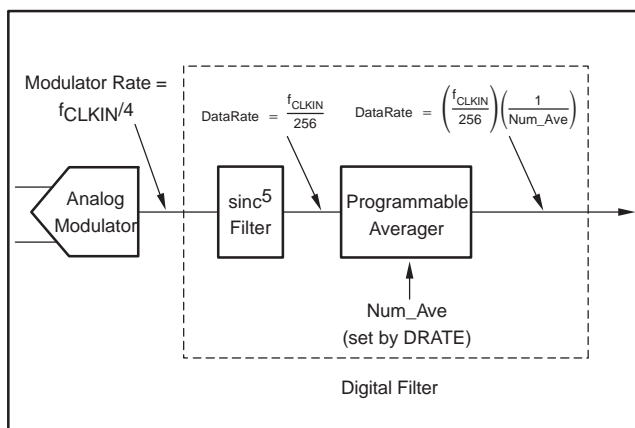

Figure 13. Block Diagram of the Analog Modulator and Digital Filter

Table 11 shows the averaging and corresponding data rate for each of the 16 valid DRATE register settings when $f_{CLKIN} = 7.68\text{MHz}$. Note that the data rate scales directly with the CLKIN frequency. For example, reducing f_{CLKIN} from 7.68MHz to 3.84MHz reduces the data rate for DR[7:0] = 11110000 from 30,000SPS to 15,000SPS.

Table 11. Number of Averages and Data Rate for Each Valid DRATE Register Setting

DRATE DR[7:0]	NUMBER OF AVERAGES FOR PROGRAMMABLE FILTER (Num_Ave)	DATA RATE(1) (SPS)
11110000	1 (averager bypassed)	30,000
11100000	2	15,000
11010000	4	7500
11000000	8	3750
10110000	15	2000
10100001	30	1000
10010010	60	500
10000010	300	100
01110010	500	60
01100011	600	50
01010011	1000	30
01000011	1200	25
00110011	2000	15
00100011	3000	10
00010011	6000	5
00000011	12,000	2.5

(1) for $f_{CLKIN} = 7.68\text{MHz}$.

FREQUENCY RESPONSE

The low-pass digital filter sets the overall frequency response for the ADS1255/6. The filter response is the product of the responses of the fixed and programmable filter sections and is given by Equation 2.

$$|H(f)| = |H_{\text{sinc5}}(f)| \cdot |H_{\text{Averager}}(f)| = \left| \frac{\sin\left(\frac{256\pi \cdot f}{f_{\text{CLKIN}}}\right)}{64 \cdot \sin\left(\frac{4\pi \cdot f}{f_{\text{CLKIN}}}\right)} \right|^5 \cdot \left| \frac{\sin\left(\frac{256\pi \cdot \text{Num_Ave} \cdot f}{f_{\text{CLKIN}}}\right)}{\text{Num_Ave} \cdot \sin\left(\frac{256\pi \cdot f}{f_{\text{CLKIN}}}\right)} \right| \quad (2)$$

The digital filter attenuates noise on the modulator output, including noise from within the ADS1255/6 and external noise present on the ADS1255/6 input signal. Adjusting the filtering by changing the number of averages used in the programmable filter changes the filter bandwidth. With a higher number of averages, bandwidth is reduced and more noise is attenuated.

The low-pass filter has notches (or zeros) at the data output rate and multiples thereof. At these frequencies, the filter has zero gain. This feature can be useful when trying to eliminate a particular interference signal. For example, to eliminate 60Hz (and the harmonics) pickup, set the data rate equal to 2.5SPS, 5SPS, 10SPS, 15SPS, 30SPS, or 60SPS. To help illustrate the filter characteristics, Figure 14 and Figure 15 show the responses at the data rate extremes of 30kSPS and 2.5SPS respectively. Table 12 summarizes the first-notch frequency and –3dB bandwidth for the different data rate settings.

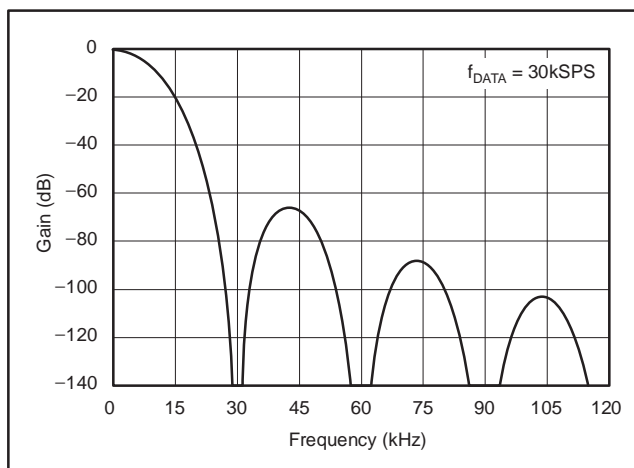

Figure 14. Frequency Response for Data Rate = 30kSPS

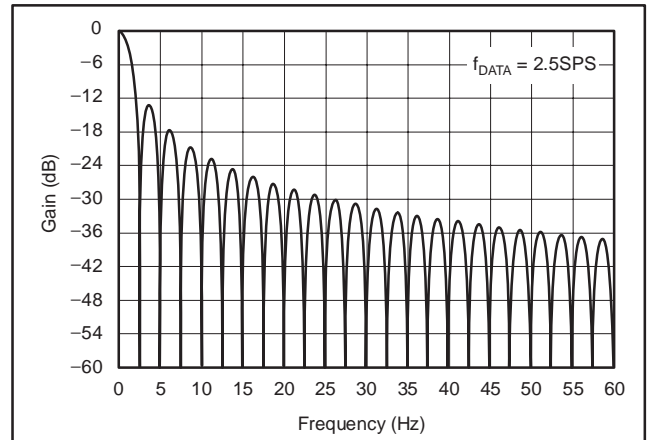

Figure 15. Frequency Response for Data Rate = 2.5SPS

Table 12. First Notch Frequency and –3dB Filter Bandwidth

DATA RATE (SPS)	FIRST NOTCH (Hz)	–3dB BANDWIDTH (Hz)
30,000	30,000	6106
15,000	15,000	4807
7500	7500	3003
3750	3750	1615
2000	2000	878
1000	1000	441
500	500	221
100	100	44.2
60 ⁽¹⁾	60	26.5
50 ⁽²⁾	50	22.1
30 ⁽¹⁾	30	13.3
25 ⁽²⁾	25	11.1
15 ⁽¹⁾	15	6.63
10 ⁽³⁾	10	4.42
5 ⁽³⁾	5	2.21
2.5 ⁽³⁾	2.5	1.1

NOTE: $f_{\text{CLKIN}} = 7.68\text{MHz}$.

(1) Notch at 60Hz.

(2) Notch at 50Hz.

(3) Notch at 50Hz and 60Hz.

The digital filter low-pass characteristic repeats at multiples of the modulator rate of $f_{\text{CLKIN}}/4$. Figure 16 and Figure 17 show the responses plotted out to 7.68MHz at the data rate extremes of 30kSPS and 2.5SPS. Notice how the responses near DC, 1.92MHz, 3.84MHz,

5.76MHz, 7.68MHz, are the same. The digital filter will attenuate high-frequency noise on the ADS1255/6 inputs up to the frequency where the response repeats. If significant noise on the inputs is present above this frequency, make sure to remove with external filtering. Fortunately, this can be done on the ADS1255/6 with a simple RC filter, as shown in the Applications Section (see Figure 25).

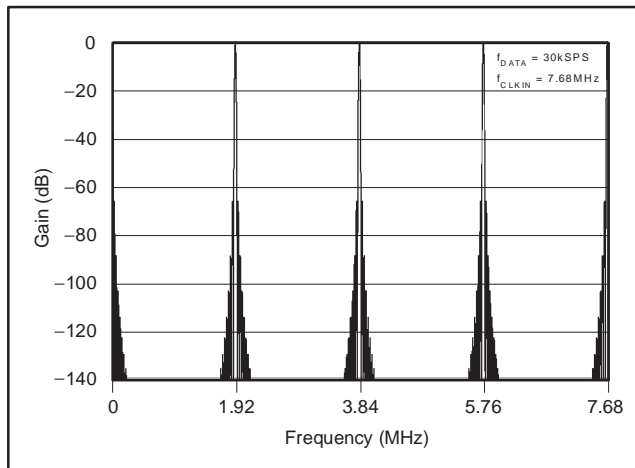

Figure 16. Frequency Response Out to 7.68MHz for Data Rate = 30kSPS

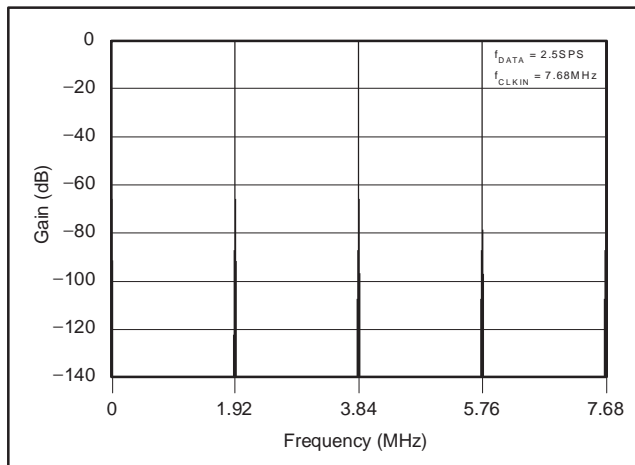

Figure 17. Frequency Response Out to 7.68MHz for Data Rate = 2.5SPS

SETTLING TIME

The ADS1255/6 features a digital filter optimized for fast settling. The settling time (time required for a step change on the analog inputs to propagate through the filter) for the different data rates is shown in Table 13. The following sections highlight the single-cycle settling ability of the filter and show various ways to control the conversion process.

Table 13. Settling Time vs Data Rate

DATA RATE (SPS)	SETTLING TIME (t_{18}) (ms)
30,000	0.21
15,000	0.25
7500	0.31
3750	0.44
2000	0.68
1000	1.18
500	2.18
100	10.18
60	16.84
50	20.18
30	33.51
25	40.18
15	66.84
10	100.18
5	200.18
2.5	400.18

NOTE: $f_{CLKIN} = 7.68MHz$.

Settling Time Using Synchronization

The $\overline{SYNC/PDWN}$ pin allows direct control of conversion timing. Simply issue a Sync command or strobe the $\overline{SYNC/PDWN}$ pin after changing the analog inputs (see the Synchronization section for more information). The conversion begins when $\overline{SYNC/PDWN}$ is taken high, stopping the current conversion and restarting the digital filter. As soon as $\overline{SYNC/PDWN}$ goes low, the \overline{DRDY} output goes high and remains high during the conversion. After the settling time (t_{18}), \overline{DRDY} goes low, indicating that data is available. The ADS1255/6 settles in a single cycle—there is no need to ignore or discard data after synchronization. Figure 18 shows the data retrieval sequence following synchronization.

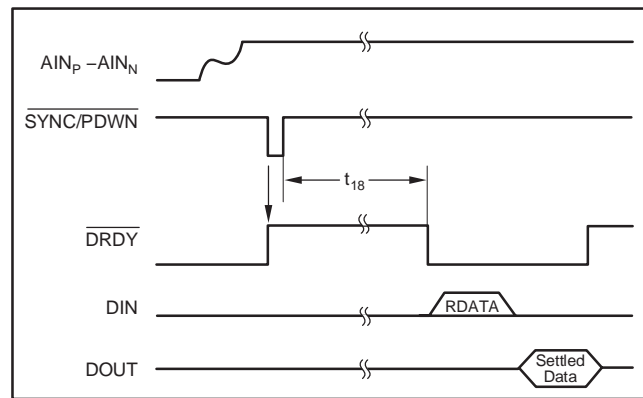

Figure 18. Data Retrieval After Synchronization

Settling Time Using the Input Multiplexer

The most efficient way to cycle through the inputs is to change the multiplexer setting (using a WREG command to the multiplexer register MUX) immediately after $\overline{\text{DRDY}}$ goes low. Then, after changing the multiplexer, restart the conversion process by issuing the SYNC and WAKEUP commands, and retrieve the data with the RDATA command. Changing the multiplexer before reading the data allows the ADS1256 to start measuring the new input channel sooner. Figure 19 demonstrates efficient input cycling. There is no need to ignore or discard data while cycling through the channels of the input multiplexer because the ADS1256 fully settles before $\overline{\text{DRDY}}$ goes low, indicating data is ready.

Step 1: When $\overline{\text{DRDY}}$ goes low, indicating that data is ready for retrieval, update the multiplexer register MUX using the WREG command. For example, setting MUX to 23h gives $\text{AIN}_P = \text{AIN}_2$, $\text{AIN}_N = \text{AIN}_3$.

Step 2: Restart the conversion process by issuing a SYNC command immediately followed by a WAKEUP command. Make sure to follow timing specification t_{11} between commands.

Step 3: Read the data from the previous conversion using the RDATA command.

Step 4: When $\overline{\text{DRDY}}$ goes low again, repeat the cycle by first updating the multiplexer register, then reading the previous data.

Table 14 gives the effective overall throughput ($1/t_{19}$) when cycling the input multiplexer. The values for throughput ($1/t_{19}$) assume the multiplexer was changed with a 3-byte WREG command and $f_{\text{SCLK}} = f_{\text{CLKIN}}/4$.

Table 14. Multiplexer Cycling Throughput

DATA RATE (SPS)	CYCLING THROUGHPUT ($1/t_{19}$) (Hz)
30,000	4374
15,000	3817
7500	3043
3750	2165
2000	1438
1000	837
500	456
100	98
60	59
50	50
30	30
25	25
15	15
10	10
5	5
2.5	2.5

NOTE: $f_{\text{CLKIN}} = 7.68\text{MHz}$.

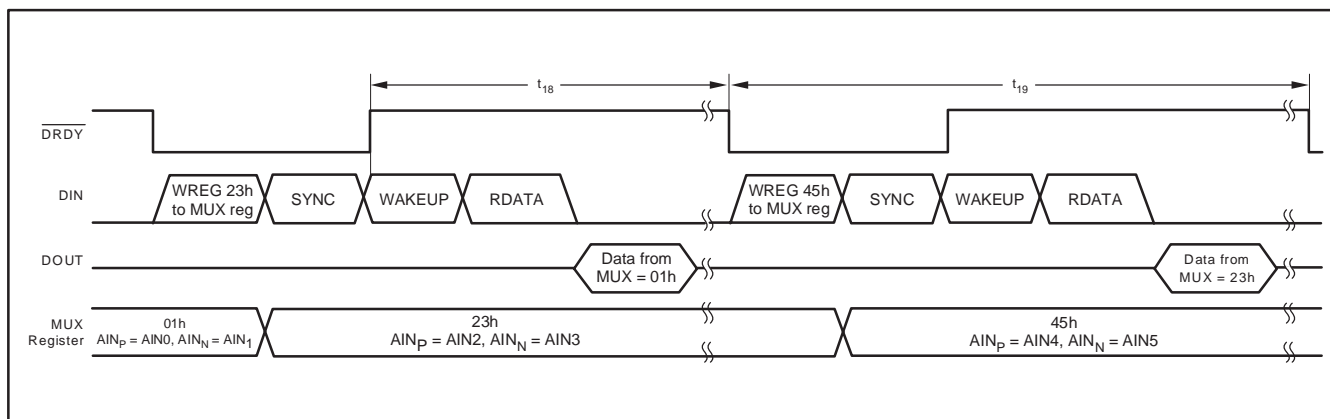

Figure 19. Cycling the ADS1256 Input Multiplexer

Settling Time Using One-Shot Mode

A dramatic reduction in power consumption can be achieved in the ADS1255/6 by performing one-shot conversions using the STANDBY command; the sequence for this is shown in Figure 20. Issue the WAKEUP command from Standby mode to begin a one-shot conversion. Following the settling time (t_{18}), \overline{DRDY} will go low, indicating that the conversion is complete and data can be read using the RDATA command. The ADS1255/6 settles in a single cycle—there is no need to ignore or discard data. Following the data read cycle, issue another STANDBY command to reduce power consumption. When ready for the next measurement, repeat the cycle starting with another WAKEUP command.

Settling Time while Continuously Converting

After a synchronization, input multiplexer change, or wakeup from Standby mode, the ADS1255/6 will continuously convert the analog input. The conversions coincide with the falling edge of \overline{DRDY} . While continuously converting, it is often more convenient to consider settling times in terms of \overline{DRDY} periods, as shown in Table 15. The \overline{DRDY} period equals the inverse of the data rate.

If there is a step change on the input signal while continuously converting, performing a synchronization operation to start a new conversion is recommended. Otherwise, the next data will represent a combination of

the previous and current input signal and should therefore be discarded. Figure 21 shows an example of readback in this situation.

Table 15. Data Settling Delay vs Data Rate

DATA RATE (SPS)	SETTLING TIME (\overline{DRDY} Periods)
30,000	5
15,000	3
7500	2
3750	1
2000	1
1000	1
500	1
100	1
60	1
50	1
30	1
25	1
15	1
10	1
5	1
2.5	1

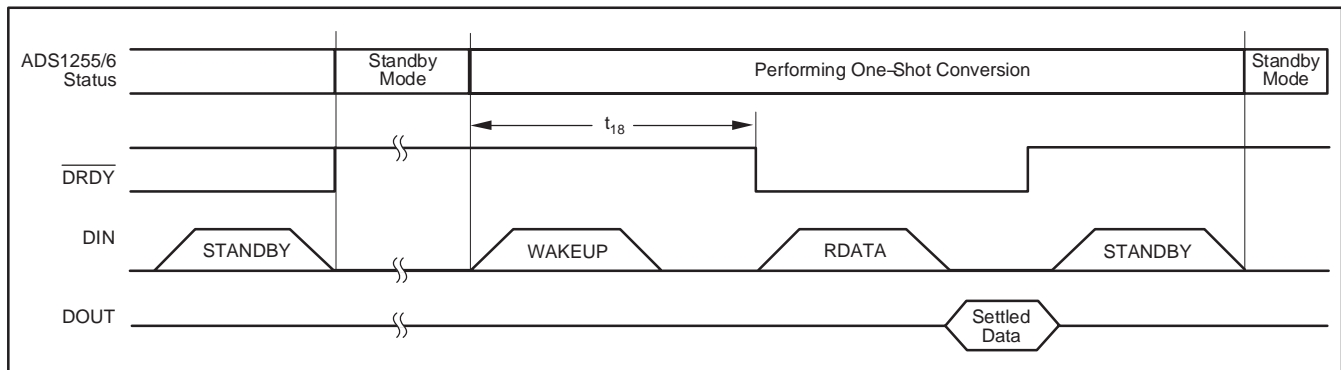

Figure 20. One-Shot Conversions Using the STANDBY Command

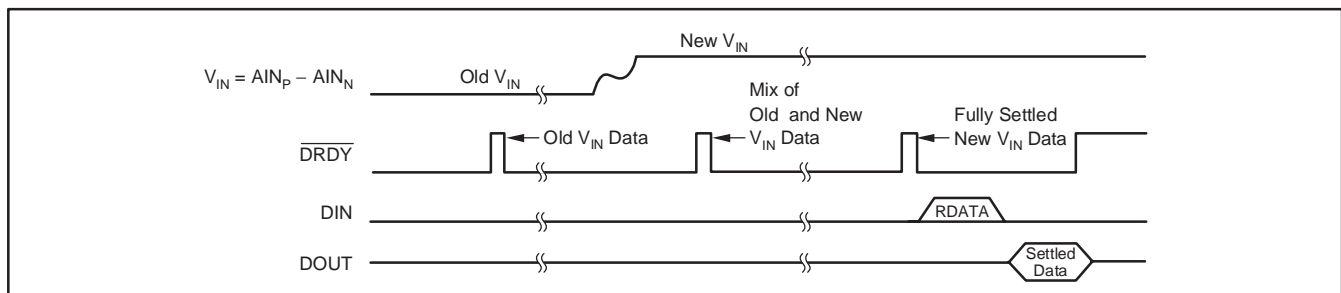

Figure 21. Step Change on V_{IN} while Continuously Converting for Data Rates ≤ 3750 SPS

DATA FORMAT

The ADS1255/6 output 24 bits of data in Binary Two's Complement format. The LSB has a weight of $2V_{REF}/(PGA(2^{23} - 1))$. A positive full-scale input produces an output code of 7FFFFFFh and the negative full-scale input produces an output code of 800000h. The output clips at these codes for signals exceeding full-scale. Table 16 summarizes the ideal output codes for different input signals.

Table 16. Ideal Output Code vs Input Signal

INPUT SIGNAL V_{IN} ($A_{INP} - A_{INN}$)	IDEAL OUTPUT CODE(1)
$\geq \frac{+2V_{REF}}{PGA}$	7FFFFFFh
$\frac{+2V_{REF}}{PGA(2^{23} - 1)}$	000001h
0	000000h
$\frac{-2V_{REF}}{PGA(2^{23} - 1)}$	FFFFFFh
$\leq \frac{-2V_{REF}}{PGA} \left(\frac{2^{23}}{2^{23} - 1} \right)$	800000h

(1) Excludes effects of noise, INL, offset, and gain errors.

GENERAL-PURPOSE DIGITAL I/O (D0-D3)

The ADS1256 has 4 pins dedicated for digital I/O and the ADS1255 has 2 digital I/O pins. All of the digital I/O pins are individually configurable as either inputs or outputs through the IO register. The DIR bits of the IO register define whether each pin is an input or output, and the DIO bits control the status of the pins. Reading back the DIO register shows the state of the digital I/O pins, whether they are configured as inputs or outputs by the DIR bits. When digital I/O pins are configured as inputs, the DIO register is used to read the state of these pins. When configured as outputs, DIO sets the output value. On the ADS1255, the digital I/O pins D2 and D3 do not exist and the settings of the IO register bits that control operation of D2 and D3 have no effect on that device.

During Standby and Power-Down modes, the GPIO remain active. If configured as outputs, they continue to drive the pins. If configured as inputs, they must be driven (not left floating) to prevent excess power dissipation.

The digital I/O pins are set as inputs after power-up or a reset, except for D0/CLKOUT, which is enabled as a clock output. If the digital I/O pins are not used, either leave them as inputs tied to ground or configure them as outputs. This prevents excess power dissipation.

CLOCK OUTPUT (D0/CLKOUT)

The clock output pin can be used to clock another device, such as a microcontroller. This clock can be configured to operate at frequencies of f_{CLKIN} , $f_{CLKIN}/2$, or $f_{CLKIN}/4$ using CLK1 and CLK0 in the ADCON register. Note that enabling the output clock and driving an external load will increase the digital power dissipation. Standby mode does not affect the clock output status. That is, if Standby is enabled, the clock output will continue to run during Standby mode. If the clock output function is not needed, it should be disabled by writing to the ADCON register after power-up or reset.

CLOCK GENERATION

The master clock source for the ADS1255/6 can be provided using an external crystal or clock generator. When the clock is generated using a crystal, external capacitors must be provided to ensure start-up and a stable clock frequency, as shown in Figure 22. Table 17 lists two recommended crystals. Long leads should be minimized with the crystal placed close to the ADS1255/6 pins. For information on ceramic resonators, see application note SBAA104, *Using Ceramic Resonators with the ADS1255/6*, available for download at www.ti.com.

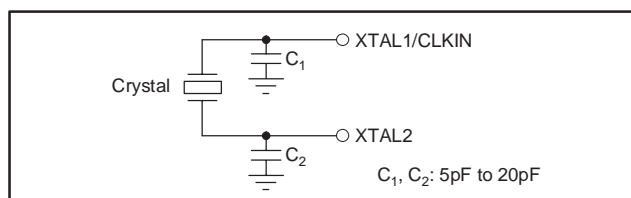

Figure 22. Crystal Connection

Table 17. Recommended Crystals

MANUFACTURER	FREQUENCY	PART NUMBER
Citizen	7.68MHz	CIA/53383
ECS	8.0MHz	ECS-80-5-4

When using a crystal, neither the XTAL1/CLKIN nor XTAL2 pins can be used to drive any other logic. If other devices need a clock source, the D0/CLKOUT pin is available for this function. When using an external clock generator, supply the clock signal to XTAL1/CLKIN and leave XTAL2 floating. Make sure the external clock generator supplies a clean clock waveform. Overshoot and glitches on the clock will degrade overall performance.

CALIBRATION

Offset and gain errors can be minimized using the ADS1255/6 onboard calibration circuitry. Figure 23 shows the calibration block diagram. Offset errors are corrected with the Offset Calibration (OFC) register and, likewise, full-scale errors are corrected with the Full-Scale Calibration (FSC) register. Each of these registers is 24-bits and can be read from or written to.

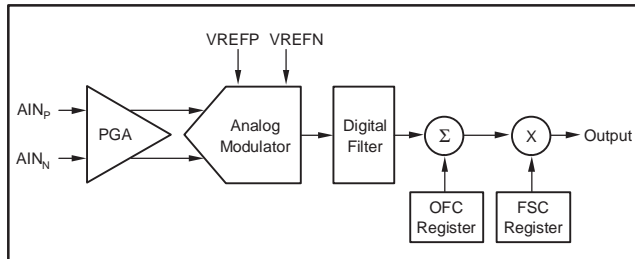

Figure 23. Calibration Block Diagram

The output of the ADS1255/6 after calibration is shown in Equation 3.

$$\text{Output} = \left(\frac{\text{PGA} \cdot V_{\text{IN}}}{2V_{\text{REF}}} - \frac{\text{OFC}}{\alpha} \right) \text{FSC} \cdot \beta \quad (3)$$

where α and β vary with data rate settings shown in Table 18 along with the ideal values (assumes perfect analog performance) for OFC and FSC. OFC is a Binary Two's Complement number that can range from $-8,388,608$ to $8,388,607$, while FSC is unipolar ranging from 0 to $16,777,215$.

The ADS1255/6 supports both self-calibration and system calibration for any PGA setting using a set of five commands: SELFOCAL, SELFSGCAL, SELFCAL, SYSOCAL, and SYSGCAL. Calibration can be done at any time, though in many applications the ADS1255/6 drift performance is low enough that a single calibration is all that is needed. $\overline{\text{DRDY}}$ goes high when calibration begins and remains so until settled data is ready afterwards. There is no need to discard data after a calibration. It is strongly recommended to issue a self-calibration command after power-up when the reference has stabilized. After a reset, the ADS1255/6 performs self-calibration. Calibration must be performed whenever the data rate changes and should be performed when the buffer configuration or PGA changes.

Table 18. Calibration Values for Different Data Rate Settings

DATA RATE (SPS)	α	β	IDEAL OFC	IDEAL FSC
30,000	400000 _H	1.8639	000000 _H	44AC08 _H
15,000	400000 _H	1.8639	000000 _H	44AC08 _H
7500	400000 _H	1.8639	000000 _H	44AC08 _H
3750	400000 _H	1.8639	000000 _H	44AC08 _H
2000	3C0000 _H	1.7474	000000 _H	494008 _H
1000	3C0000 _H	1.7474	000000 _H	494008 _H
500	3C0000 _H	1.7474	000000 _H	494008 _H
100	4B0000 _H	2.1843	000000 _H	3A99A0 _H
60	3E8000 _H	1.8202	000000 _H	4651F3 _H
50	4B0000 _H	2.1843	000000 _H	3A99A0 _H
30	3E8000 _H	1.8202	000000 _H	4651F3 _H
25	4B0000 _H	2.1843	000000 _H	3A99A0 _H
15	3E8000 _H	1.8202	000000 _H	4651F3 _H
10	5DC000 _H	2.7304	000000 _H	2EE14C _H
5	5DC000 _H	2.7304	000000 _H	2EE14C _H
2.5	5DC000 _H	2.7304	000000 _H	2EE14C _H

Self-Calibration

Self-calibration corrects internal offset and gain errors. During self-calibration, the appropriate calibration signals are applied internally to the analog inputs.

SELFOCAL performs a self offset calibration. The analog inputs AIN_P and AIN_N are disconnected from the signal source and connected to $AVDD/2$. See Table 19 for the time required for self offset calibration for the different data rate settings. As with most of the ADS1255/6 timings, the calibration time scales directly with f_{CLKIN} . Self offset calibration updates the OFC register.

Table 19. Self Offset and System Offset Calibration Timing

DATA RATE (SPS)	SELF OFFSET CALIBRATION AND SYSTEM OFFSET CALIBRATION TIME
30,000	387 μ s
15,000	453 μ s
7500	587 μ s
3750	853 μ s
2000	1.3ms
1000	2.3ms
500	4.3ms
100	20.3ms
60	33.7ms
50	40.3ms
30	67.0ms
25	80.3ms
15	133.7ms
10	200.3ms
5	400.3ms
2.5	800.3ms

NOTE: For $f_{CLKIN} = 7.68$ MHz.

SELFGCAL performs a self gain calibration. The analog inputs AIN_P and AIN_N are disconnected from the signal source and AIN_P is connected internally to $VREFP$ while AIN_N is connected to $VREFN$. Self gain calibration can be used with any PGA setting, and the ADS1255/6 has excellent gain calibration even for the higher PGA settings, as shown in the Typical Characteristics section. Using the buffer will limit the common-mode range of the reference inputs during self gain calibration since they will be connected to the buffer inputs and must be within the specified analog input range. When the voltage on $VREFP$ or $VREFN$ exceeds the buffer analog input range ($AVDD - 2.0V$), the buffer must be turned off during self gain calibration. Otherwise, use system gain calibration or write the gain coefficients directly to the FSC register. Table 20 shows the time required for self gain calibration for the different data rate and PGA settings. Self gain calibration updates the FSC register.

Table 20. Self Gain Calibration Timing

DATA RATE (SPS)	PGA SETTING				
	1	2	4	8	16, 32, 64
30,000	417 μ s	417 μ s	451 μ s	517 μ s	651 μ s
15,000	484 μ s	484 μ s	484 μ s	551 μ s	551 μ s
7500	617 μ s	617 μ s	617 μ s	617 μ s	751 μ s
3750	884				
2000	1.4ms				
1000	2.4ms				
500	4.5ms				
100	21.0ms				
60	34.1ms				
50	41.7ms				
30	67.8ms				
25	83.0ms				
15	135.3ms				
10	207.0ms				
5	413.7ms				
2.5	827.0ms				

NOTE: For $f_{CLKIN} = 7.68$ MHz.

SELFCAL performs first a self offset and then a self gain calibration. The analog inputs are disconnected from the signal source during self-calibration. When using the input buffer with self-calibration, make sure to observe the common-mode range of the reference inputs as described above. Table 21 shows the time required for self-calibration for the different data rate settings. Self-calibration updates both the OFC and FSC registers.

Table 21. Self-Calibration Timing

DATA RATE (SPS)	PGA SETTING				
	1	2	4	8	16, 32, 64
30,000	596 μ s	596 μ s	692 μ s	696 μ s	892 μ s
15,000	696 μ s	696 μ s	696 μ s	762 μ s	896 μ s
7500	896 μ s	896 μ s	896 μ s	896 μ s	1029 μ s
3750	1.3ms				
2000	2.0ms				
1000	3.6ms				
500	6.6ms				
100	31.2ms				
60	50.9ms				
50	61.8ms				
30	101.3ms				
25	123.2ms				
15	202.1ms				
10	307.2ms				
5	613.8ms				
2.5	1227.2ms				

NOTE: For $f_{CLKIN} = 7.68$ MHz.

System Calibration

System calibration corrects both internal and external offset and gain errors using the SYSOCAL and SYSGCAL commands. During system calibration, the appropriate calibration signals must be applied by the user to the inputs.

SYSOCAL performs a system offset calibration. The user must supply a zero input differential signal. The ADS1255/6 then computes a value that will nullify the offset in the system. Table 22 shows the time required for system offset calibration for the different data rate settings. Note this timing is the same for the self offset calibration. System offset calibration updates the OFC register.

SYSGCAL performs a system gain calibration. The user must supply a full-scale input signal to the ADS1255/6. The ADS1255/6 then computes a value to nullify the gain error in the system. System gain calibration can correct inputs that are 80% of the full-scale input voltage and larger. Make sure not to exceed the full-scale input voltage when using system gain calibration. Table 22 shows the time required for system gain calibration for the different data rate settings. System gain calibration updates the FSC register.

Table 22. System Gain Calibration Timing

DATA RATE (SPS)	SYSTEM GAIN CALIBRATION TIME
30,000	417µs
15,000	484µs
7500	617µs
3750	884µs
2000	1.4ms
1000	2.4ms
500	4.4ms
100	20.4ms
60	33.7ms
50	40.4ms
30	67.0ms
25	80.4ms
15	133.7ms
10	200.4ms
5	400.4ms
2.5	800.4ms

NOTE: For $f_{CLKIN} = 7.68\text{MHz}$.

Auto-Calibration

Auto-calibration can be enabled (ACAL bit in ADCON register) to have the ADS1255/6 automatically initiate a self-calibration at the completion of a write command (WREG) that changes the data rate, PGA setting, or Buffer status.

SERIAL INTERFACE

The SPI-compatible serial interface consists of four signals: \overline{CS} , SCLK, DIN, and DOUT, and allows a controller to communicate with the ADS1255/6. The programmable functions are controlled using a set of on-chip registers. Data is written to and read from these registers via the serial interface

The \overline{DRDY} output line is used as a status signal to indicate when a conversion has been completed. \overline{DRDY} goes low when new data is available. The Timing Specification shows the timing diagram for interfacing to the ADS1255/6.

CHIP SELECT (\overline{CS})

The chip select (\overline{CS}) input allows individual selection of a ADS1255/6 device when multiple devices share the serial bus. \overline{CS} must remain low for the duration of the serial communication. When \overline{CS} is taken high, the serial interface is reset and DOUT enters a high impedance state. \overline{CS} may be permanently tied low.

SERIAL CLOCK (SCLK)

The serial clock (SCLK) features a Schmitt-triggered input and is used to clock data on the DIN and DOUT pins into and out of the ADS1255/6. Even though the input has hysteresis, it is recommended to keep SCLK as clean as possible to prevent glitches from accidentally shifting the data. If SCLK is held low for 32 \overline{DRDY} periods, the serial interface will reset and the next SCLK pulse will start a new communication cycle. This timeout feature can be used to recover communication when a serial interface transmission is interrupted. A special pattern on SCLK will reset the chip; see the RESET section for more details on this procedure.

DATA INPUT (DIN) AND DATA OUTPUT (DOUT)

The data input pin (DIN) is used along with SCLK to send data to the ADS1255/6. The data output pin (DOUT) along with SCLK is used to read data from the ADS1255/6. Data on DIN is shifted into the part on the falling edge of SCLK while data is shifted out on DOUT on the rising edge of SCLK. DOUT is high impedance when not in use to allow DIN and DOUT to be connected together and be driven by a bi-directional bus. Note: the RDATA command must not be issued while DIN and DOUT are connected together.

DATA READY ($\overline{\text{DRDY}}$)

The $\overline{\text{DRDY}}$ output is used as a status signal to indicate when conversion data is ready to be read. $\overline{\text{DRDY}}$ goes low when new conversion data is available. It is reset high when all 24 bits have been read back using Read Data (RDATA) or Read Data Continuous (RDATA) command. It also goes high when the new conversion data is being updated. Do not retrieve during this update period as the data is invalid. If data is not retrieved, $\overline{\text{DRDY}}$ will only be high during the update time as shown in Figure 24.

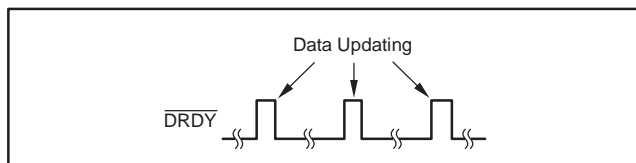

Figure 24. $\overline{\text{DRDY}}$ with No Data Retrieval

After changing the PGA, data rate, buffer status, writing to the OFC or FSC registers, and enabling or disabling the sensor detect circuitry, perform a synchronization operation to force $\overline{\text{DRDY}}$ high. It will stay high until valid data is ready. If auto-calibration is enabled (by setting the ACAL bit in the ADCON register), $\overline{\text{DRDY}}$ will go low after the self-calibration is complete and new data is valid. Exiting from Reset, Synchronization, Standby or Power-Down mode will also force $\overline{\text{DRDY}}$ high. $\overline{\text{DRDY}}$ will go low as soon as valid data is ready.

SYNCHRONIZATION

Synchronization of the ADS1255/6 is available to coordinate the A/D conversion with an external event and also to speed settling after an instantaneous change on the analog inputs (see Conversion Time using Synchronization section).

Synchronization can be achieved either using the $\overline{\text{SYNC/PDWN}}$ pin or with the SYNC command. To use the $\overline{\text{SYNC/PDWN}}$ pin, take it low and then high, making sure to meet timing specification t_{16} . Synchronization occurs on the first rising edge of the master clock after $\overline{\text{SYNC/PDWN}}$ is taken high. No communication is possible on the serial interface while $\overline{\text{SYNC/PDWN}}$ is low. If the $\overline{\text{SYNC/PDWN}}$ pin is held low for 20 $\overline{\text{DRDY}}$ periods the ADS1255/6 will enter Power-Down mode.

To synchronize using the SYNC command, first shift in all eight bits of the SYNC command. This stops the operation of the ADS1255/6. When ready to synchronize, issue the WAKEUP command. Synchronization occurs on the first rising edge of the master clock after the first SCLK used to shift in the WAKEUP command. After a synchronization operation, either with the $\overline{\text{SYNC/PDWN}}$ pin or the SYNC command, $\overline{\text{DRDY}}$ stays high until valid data is ready.

STANDBY MODE

The standby mode shuts down all of the analog circuitry and most of the digital features. The oscillator continues to run to allow for fast wakeup. If enabled, clock output D0/CLKOUT will also continue to run during during Standby mode. To enter Standby mode, issue the STANDBY command. To exit Standby mode, issue the WAKEUP command. $\overline{\text{DRDY}}$ will stay high after exiting Standby mode until valid data is ready. Standby mode can be used to perform one-shot conversions; see Settling Time Using One-Shot Mode section for more details.

POWER-DOWN MODE

Holding the $\overline{\text{SYNC/PDWN}}$ pin low for 20 $\overline{\text{DRDY}}$ cycles activates the Power-Down mode. During Power-Down mode, all circuitry is disabled including the oscillator and the clock output.

To exit Power-Down mode, take the $\overline{\text{SYNC/PDWN}}$ pin high. Upon exiting from Power-Down mode, the ADS1255/6 crystal oscillator typically requires 30ms to wake up. If using an external clock source, 8192 CLKIN cycles are needed before conversions begin.

RESET

There are three methods to reset the ADS1255/6: the $\overline{\text{RESET}}$ input pin, RESET command, and a special SCLK reset pattern.

When using the $\overline{\text{RESET}}$ pin, take it low to force a reset. Make sure to follow the minimum pulse width timing specifications before taking the $\overline{\text{RESET}}$ pin back high.

The RESET command takes effect after all eight bits have been shifted into DIN. Afterwards, the reset releases automatically.

The ADS1255/6 can also be reset with a special pattern on SCLK (see Figure 2). Reset occurs on the falling edge of the last SCLK edge in the pattern. After performing the operation, the reset releases automatically.

On reset, the configuration registers are initialized to their default state except for the CLK0 and CLK1 bits in the ADCON register that control the D0/CLKOUT pin. These bits are only initialized to the default state when RESET is performed using the $\overline{\text{RESET}}$ pin. After releasing from RESET, self-calibration is performed, regardless of the reset method or the state of the ACAL bit before RESET.

POWER-UP

All of the configuration registers are initialized to their default state at power-up. A self-calibration is then performed automatically. For the best performance, it is strongly recommended to perform an additional self-calibration by issuing the SELFCAL command after the power supplies and voltage reference have had time to settle to their final values.

APPLICATIONS INFORMATION

GENERAL RECOMMENDATIONS

The ADS1255 and ADS1256 are very high-resolution A/D converters. Getting the optimal performance from them requires careful attention to their support circuitry and printed circuit board (PCB) design. Figure 25 shows the basic connections for the ADS1255. It is recommended to use a single ground plane for both the analog and digital supplies. This ground plane should be shared with the bypass capacitors and analog conditioning circuits. However, avoid using this ground plane for noisy digital components such as microprocessors. If a split ground plane is used with the ADS1255/6, make sure the analog and digital planes are tied together. There should not be a voltage difference between the ADS1255/6 analog and digital ground pins (AGND and DGND).

As with any precision circuit, use good supply bypassing techniques. A smaller value ceramic capacitor in parallel with a larger value tantalum or a larger value low-voltage ceramic capacitor works well. Place the capacitors, in particular the ceramic ones, close to the supply pins. Run the digital logic off as low of voltage as possible. This helps reduce coupling back to the analog inputs. Avoid ringing on the digital inputs. Small resistors ($\approx 100\Omega$) in series with

the digital pins can help by controlling the trace impedance. When not using the RESET or SYNC/PDWN inputs, tie directly to the ADS1255/6 DVDD pin.

Pay special attention to the reference and analog inputs. These are the most critical circuits. On the voltage reference inputs, bypass with low equivalent series resistance (ESR) capacitors. Make these capacitors as large as possible to maximize the filtering on the reference. With the outstanding performance of the ADS1255/6, it is easy for the voltage reference to limit overall performance if not carefully selected. When using a stand-alone reference, make sure it is very low noise and very low drift. Ratiometric measurements, where the input signal and reference track each other, are somewhat less sensitive, but verify the reference signal is clean.

Often times, only a simple RC filter (as shown in Figure 25) is needed on the inputs. This circuit limits the high-frequency noise near the modulator frequency; see the Frequency Response section. Avoid low-grade dielectrics for the capacitors to minimize temperature variations and leakage. Keep the input traces as short as possible and place the components close to the input pins. When using the ADS1256, make sure to filter all the input channels being used.

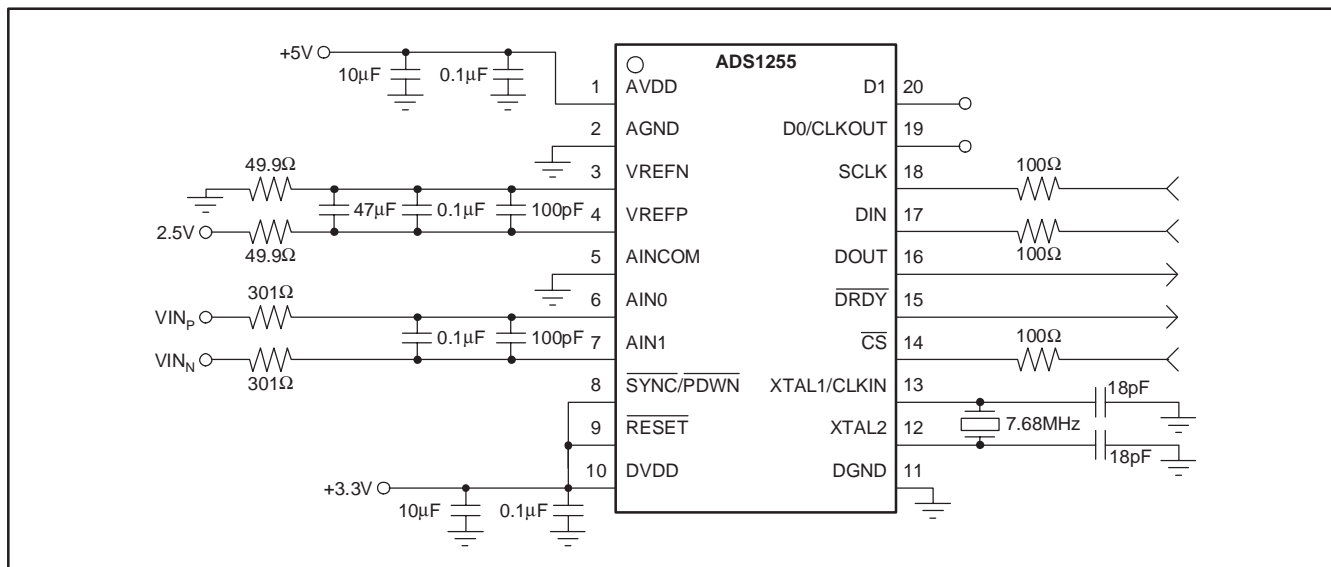

Figure 25. ADS1255 Basic Connections

DIGITAL INTERFACE CONNECTIONS

The ADS1255/6 5V tolerant SPI-, QSPI™, and MICROWIRE™-compatible interface easily connects to a wide variety of microcontrollers. Figure 26 shows the basic connection to TI's MSP430 family of low-power microcontrollers. Figure 27 shows the connection to microcontrollers with an SPI interface like TI's MSC12xx family or the 68HC11 family. Note that the MSC12xx includes a high-resolution A/D converter; the ADS1255/6 can be used to add additional channels of measurement or provide higher-speed conversions. Finally, Figure 28 shows how to connect the ADS1255/6 to an 8xC51 UART in serial mode 0 in a 2-wire configuration. Avoid using the continuous read mode (RDATA_C) when DIN and DOUT are connected together.

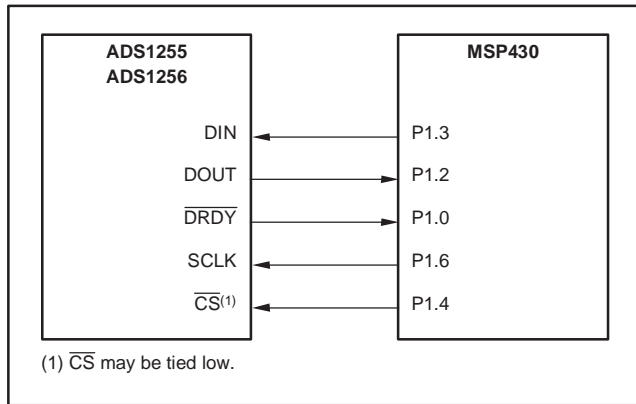

Figure 26. Connection to MSP430 Microcontroller

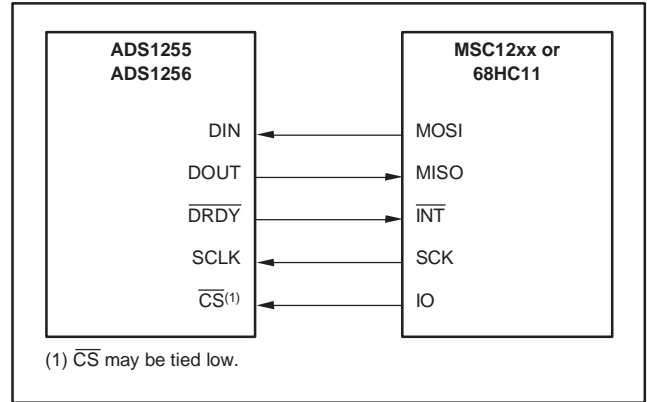

Figure 27. Connection to Microcontrollers with an SPI Interface

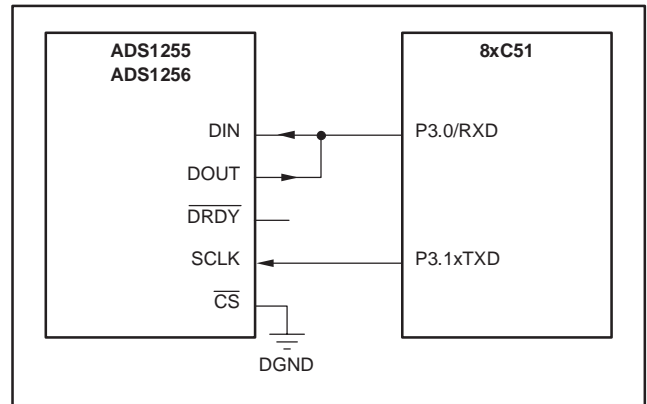

Figure 28. Connection to 8xC51 Microcontroller UART with a 2-Wire Interface

REGISTER MAP

The operation of the ADS1255/6 is controlled through a set of registers. Collectively, the registers contain all the information needed to configure the part, such as data rate, multiplexer settings, PGA setting, calibration, etc., and are listed in Table 23.

Table 23. Register Map

ADDRESS	REGISTER	RESET VALUE	BIT 7	BIT 6	BIT 5	BIT 4	BIT 3	BIT 2	BIT 1	BIT 0
00h	STATUS	x1 _H	ID3	ID2	ID1	ID0	ORDER	ACAL	BUFEN	DRDY
01h	MUX	01 _H	PSEL3	PSEL2	PSEL1	PSEL0	NSEL3	NSEL2	NSEL1	NSEL0
02h	ADCON	20 _H	0	CLK1	CLK0	SDCS1	SDCS0	PGA2	PGA1	PGA0
03h	DRATE	F0 _H	DR7	DR6	DR5	DR4	DR3	DR2	DR1	DR0
04h	IO	E0 _H	DIR3	DIR2	DIR1	DIR0	DIO3	DIO2	DIO1	DIO0
05h	OFC0	xx _H	OFC07	OFC06	OFC05	OFC04	OFC03	OFC02	OFC01	OFC00
06h	OFC1	xx _H	OFC15	OFC14	OFC13	OFC12	OFC11	OFC10	OFC09	OFC08
07h	OFC2	xx _H	OFC23	OFC22	OFC21	OFC20	OFC19	OFC18	OFC17	OFC16
08h	FSC0	xx _H	FSC07	FSC06	FSC05	FSC04	FSC03	FSC02	FSC01	FSC00
09h	FSC1	xx _H	FSC15	FSC14	FSC13	FSC12	FSC11	FSC10	FSC09	FSC08
0Ah	FSC2	xx _H	FSC23	FSC22	FSC21	FSC20	FSC19	FSC18	FSC17	FSC16

STATUS : STATUS REGISTER (ADDRESS 00h)

Reset Value = x1h

BIT 7	BIT 6	BIT 5	BIT 4	BIT 3	BIT 2	BIT 1	BIT 0
ID	ID	ID	ID	ORDER	ACAL	BUFEN	DRDY

Bits 7-4 **ID3, ID2, ID1, ID0** Factory Programmed Identification Bits (Read Only)

Bit 3 **ORDER**: Data Output Bit Order

0 = Most Significant Bit First (default)

1 = Least Significant Bit First

Input data is always shifted in most significant byte and bit first. Output data is always shifted out most significant byte first. The ORDER bit only controls the bit order of the output data within the byte.

Bit 2 **ACAL**: Auto-Calibration

0 = Auto-Calibration Disabled (default)

1 = Auto-Calibration Enabled

When Auto-Calibration is enabled, self-calibration begins at the completion of the WREG command that changes the PGA (bits 0-2 of ADCON register), DR (bits 7-0 in the DRATE register) or BUFEN (bit 1 in the STATUS register) values.

Bit 1 **BUFEN**: Analog Input Buffer Enable

0 = Buffer Disabled (default)

1 = Buffer Enabled

Bit 0 **DRDY**: Data Ready (Read Only)

This bit duplicates the state of the DRDY pin.

MUX : Input Multiplexer Control Register (Address 01h)

Reset Value = 01h

BIT 7	BIT 6	BIT 5	BIT 4	BIT 3	BIT 2	BIT 1	BIT 0
PSEL3	PSEL2	PSEL1	PSEL0	NSEL3	NSEL2	NSEL1	NSEL0

Bits 7-4 **PSEL3, PSEL2, PSEL1, PSEL0**: Positive Input Channel (AIN_P) Select

- 0000 = AIN0 (default)
- 0001 = AIN1
- 0010 = AIN2 (ADS1256 only)
- 0011 = AIN3 (ADS1256 only)
- 0100 = AIN4 (ADS1256 only)
- 0101 = AIN5 (ADS1256 only)
- 0110 = AIN6 (ADS1256 only)
- 0111 = AIN7 (ADS1256 only)
- 1xxx = AINCOM (when PSEL3 = 1, PSEL2, PSEL1, PSEL0 are “don’t care”)

NOTE: When using an ADS1255 make sure to only select the available inputs.

Bits 3-0 **NSEL3, NSEL2, NSEL1, NSEL0**: Negative Input Channel (AIN_N) Select

- 0000 = AIN0
- 0001 = AIN1 (default)
- 0010 = AIN2 (ADS1256 only)
- 0011 = AIN3 (ADS1256 only)
- 0100 = AIN4 (ADS1256 only)
- 0101 = AIN5 (ADS1256 only)
- 0110 = AIN6 (ADS1256 only)
- 0111 = AIN7 (ADS1256 only)
- 1xxx = AINCOM (when NSEL3 = 1, NSEL2, NSEL1, NSEL0 are “don’t care”)

NOTE: When using an ADS1255 make sure to only select the available inputs.

ADCON: A/D Control Register (Address 02h)

Reset Value = 20h

BIT 7	BIT 6	BIT 5	BIT 4	BIT 3	BIT 2	BIT 1	BIT 0
0	CLK1	CLK0	SDCS1	SDCS0	PGA2	PGA1	PGA0

Bit 7 Reserved, always 0 (Read Only)

Bits 6-5 **CLK1, CLK0**: D0/CLKOUT Clock Out Rate Setting

- 00 = Clock Out OFF
- 01 = Clock Out Frequency = f_{CLKIN} (default)
- 10 = Clock Out Frequency = $f_{CLKIN}/2$
- 11 = Clock Out Frequency = $f_{CLKIN}/4$

When not using CLKOUT, it is recommended that it be turned off. These bits can only be reset using the \overline{RESET} pin.

Bits 4-2 **SDCS1, SDCS0**: Sensor Detect Current Sources

- 00 = Sensor Detect OFF (default)
- 01 = Sensor Detect Current = 0.5 μ A
- 10 = Sensor Detect Current = 2 μ A
- 11 = Sensor Detect Current = 10 μ A

The Sensor Detect Current Sources can be activated to verify the integrity of an external sensor supplying a signal to the ADS1255/6. A shorted sensor produces a very small signal while an open-circuit sensor produces a very large signal.

Bits 2-0 **PGA2, PGA1, PGA0**: Programmable Gain Amplifier Setting

- 000 = 1 (default)
- 001 = 2
- 010 = 4
- 011 = 8
- 100 = 16
- 101 = 32
- 110 = 64
- 111 = 64

DRATE: A/D Data Rate (Address 03h)

Reset Value = F0h

BIT 7	BIT 6	BIT 5	BIT 4	BIT 3	BIT 2	BIT 1	BIT 0
DR7	DR6	DR5	DR4	DR3	DR2	DR1	DR0

The 16 valid Data Rate settings are shown below. Make sure to select a valid setting as the invalid settings may produce unpredictable results.

Bits 7-0 **DR[7: 0]**: Data Rate Setting⁽¹⁾

- 11110000 = 30,000SPS (default)
- 11100000 = 15,000SPS
- 11010000 = 7,500SPS
- 11000000 = 3,750SPS
- 10110000 = 2,000SPS
- 10100001 = 1,000SPS
- 10010010 = 500SPS
- 10000010 = 100SPS
- 01110010 = 60SPS
- 01100011 = 50SPS
- 01010011 = 30SPS
- 01000011 = 25SPS
- 00110011 = 15SPS
- 00100011 = 10SPS
- 00010011 = 5SPS
- 00000011 = 2.5SPS

⁽¹⁾ for $f_{CLKIN} = 7.68\text{MHz}$. Data rates scale linearly with f_{CLKIN} .

I/O: GPIO Control Register (Address 04H)

Reset Value = E0h

BIT 7	BIT 6	BIT 5	BIT 4	BIT 3	BIT 2	BIT 1	BIT 0
DIR3	DIR2	DIR1	DIR0	DIO3	DIO2	DIO1	DIO0

The states of these bits control the operation of the general-purpose digital I/O pins. The ADS1256 has 4 I/O pins: D3, D2, D1, and D0/CLKOUT. The ADS1255 has two digital I/O pins: D1 and D0/CLKOUT. When using an ADS1255, the register bits DIR3, DIR2, DIO3, and DIO2 can be read from and written to but have no effect.

Bit 7 **DIR3**, Digital I/O Direction for Digital I/O Pin D3 (used on ADS1256 only)

- 0 = D3 is an output
- 1 = D3 is an input (default)

Bit 6 **DIR2**, Digital I/O Direction for Digital I/O Pin D2 (used on ADS1256 only)

- 0 = D2 is an output
- 1 = D2 is an input (default)

Bit 5 **DIR1**, Digital I/O Direction for Digital I/O Pin D1

- 0 = D1 is an output
- 1 = D1 is an input (default)

Bit 4 **DIR0**, Digital I/O Direction for Digital I/O Pin D0/CLKOUT

- 0 = D0/CLKOUT is an output (default)
- 1 = D0/CLKOUT is an input

Bits 3-0 **DIO[3:0]**: Status of Digital I/O Pins D3, D2, D1, D0/CLKOUT

Reading these bits will show the state of the corresponding digital I/O pin, whether if the pin is configured as an input or output by DIR3-DIR0. When the digital I/O pin is configured as an output by the DIR bit, writing to the corresponding DIO bit will set the output state. When the digital I/O pin is configured as an input by the DIR bit, writing to the corresponding DIO bit will have no effect. When D0/CLKOUT is configured as an output and CLKOUT is enabled (using CLK1, CLK0 bits in the ADCON register), writing to DIO0 will have no effect.

OFC0: Offset Calibration Byte 0, least significant byte (Address 05h)

Reset value depends on calibration results.

BIT 7	BIT 6	BIT 5	BIT 4	BIT 3	BIT 2	BIT 1	BIT 0
OFC07	OFC06	OFC05	OFC04	OFC03	OFC02	OFC01	OFC00

OFC1: Offset Calibration Byte 1 (Address 06h)

Reset value depends on calibration results.

BIT 7	BIT 6	BIT 5	BIT 4	BIT 3	BIT 2	BIT 1	BIT 0
OFC15	OFC14	OFC13	OFC12	OFC11	OFC10	OFC09	OFC08

OFC2: Offset Calibration Byte 2, most significant byte (Address 07h)

Reset value depends on calibration results.

BIT 7	BIT 6	BIT 5	BIT 4	BIT 3	BIT 2	BIT 1	BIT 0
OFC23	OFC22	OFC21	OFC20	OFC19	OFC18	OFC17	OFC16

FSC0: Full-scale Calibration Byte 0, least significant byte (Address 08h)

Reset value depends on calibration results.

BIT 7	BIT 6	BIT 5	BIT 4	BIT 3	BIT 2	BIT 1	BIT 0
FSC07	FSC06	FSC05	FSC04	FSC03	FSC02	FSC01	FSC00

FSC1: Full-scale Calibration Byte 1 (Address 09h)

Reset value depends on calibration results.

BIT 7	BIT 6	BIT 5	BIT 4	BIT 3	BIT 2	BIT 1	BIT 0
FSC15	FSC14	FSC13	FSC12	FSC11	FSC10	FSC09	FSC08

FSC2: Full-scale Calibration Byte 2, most significant byte (Address 0Ah)

Reset value depends on calibration results.

BIT 7	BIT 6	BIT 5	BIT 4	BIT 3	BIT 2	BIT 1	BIT 0
FSC23	FSC22	FSC21	FSC20	FSC19	FSC18	FSC17	FSC16

COMMAND DEFINITIONS

The commands summarized in Table 24 control the operation of the ADS1255/6. All of the commands are stand-alone except for the register reads and writes (RREG, WREG) which require a second command byte plus data. Additional command and data bytes may be shifted in without delay after the first command byte. The ORDER bit in the STATUS register sets the order of the bits within the output data. \overline{CS} must stay low during the entire command sequence.

Table 24. Command Definitions

COMMAND	DESCRIPTION	1ST COMMAND BYTE	2ND COMMAND BYTE
WAKEUP	Completes SYNC and Exits Standby Mode	0000 0000 (00h)	
RDATA	Read Data	0000 0001 (01h)	
RDATAAC	Read Data Continuously	0000 0011 (03h)	
SDATAAC	Stop Read Data Continuously	0000 1111 (0Fh)	
RREG	Read from REG <i>rrr</i>	0001 <i>rrr</i> (1xh)	0000 <i>nnnn</i>
WREG	Write to REG <i>rrr</i>	0101 <i>rrr</i> (5xh)	0000 <i>nnnn</i>
SELF CAL	Offset and Gain Self-Calibration	1111 0000 (F0h)	
SELF OCAL	Offset Self-Calibration	1111 0001 (F1h)	
SELF GCAL	Gain Self-Calibration	1111 0010 (F2h)	
YSOCAL	System Offset Calibration	1111 0011 (F3h)	
YSGCAL	System Gain Calibration	1111 0100 (F4h)	
SYNC	Synchronize the A/D Conversion	1111 1100 (FCh)	
STANDBY	Begin Standby Mode	1111 1101 (FDh)	
RESET	Reset to Power-Up Values	1111 1110 (FEh)	
WAKEUP	Completes SYNC and Exits Standby Mode	1111 1111 (FFh)	

NOTE: *n* = number of registers to be read/written – 1. For example, to read/write three registers, set *nnnn* = 2 (0010).
r = starting register address for read/write commands.

RDATA: Read Data

Description: Issue this command after \overline{DRDY} goes low to read a single conversion result. After all 24 bits have been shifted out on DOUT, \overline{DRDY} goes high. It is not necessary to read back all 24 bits, but \overline{DRDY} will then not return high until new data is being updated. See the Timing Characteristics for the required delay between the end of the RDATA command and the beginning of shifting data on DOUT: t_6 .

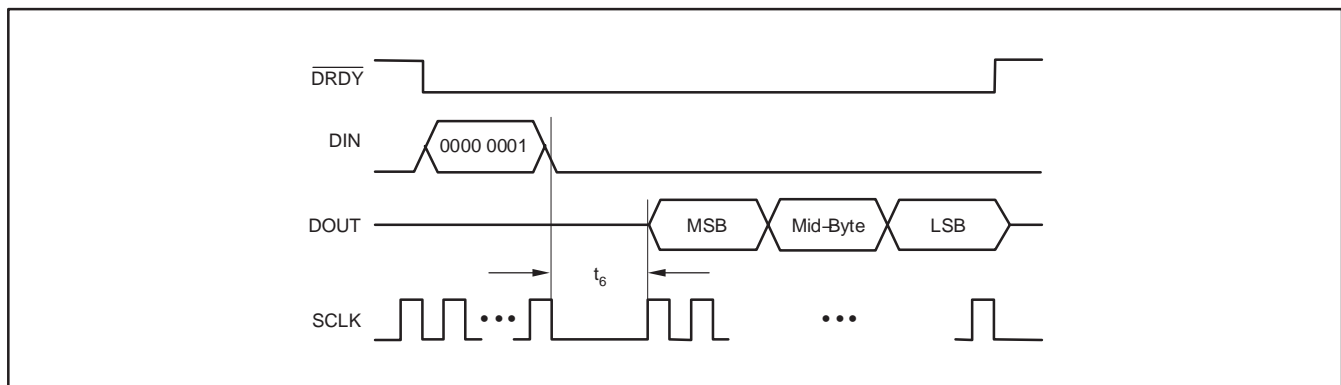

Figure 29. RDATA Command Sequence

RDATAC: Read Data Continuous

Description: Issue command after $\overline{\text{DRDY}}$ goes low to enter the Read Data Continuous mode. This mode enables the continuous output of new data on each $\overline{\text{DRDY}}$ without the need to issue subsequent read commands. After all 24 bits have been read, $\overline{\text{DRDY}}$ goes high. It is not necessary to read back all 24 bits, but $\overline{\text{DRDY}}$ will then not return high until new data is being updated. This mode may be terminated by the Stop Read Data Continuous command (STOPC). Because DIN is constantly being monitored during the Read Data Continuous mode for the STOPC or RESET command, do not use this mode if DIN and DOUT are connected together. See the Timing Characteristics for the required delay between the end of the RDATAC command and the beginning of shifting data on DOUT: t_6 .

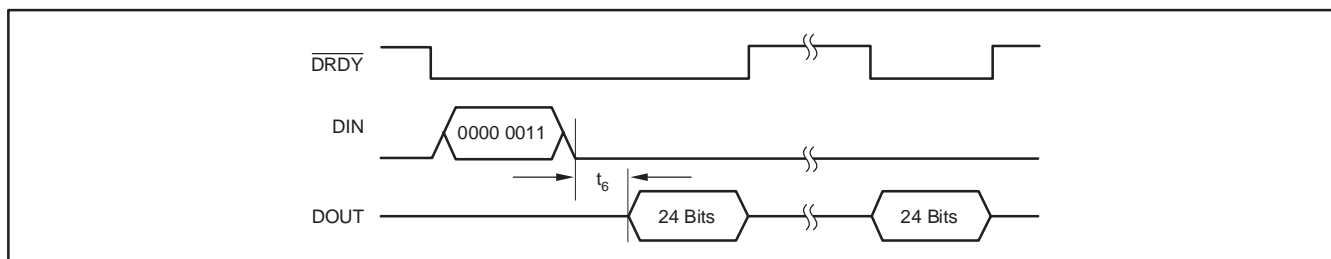

Figure 30. RDATAC Command Sequence

On the following $\overline{\text{DRDY}}$, shift out data by applying SCLKs. The Read Data Continuous mode terminates if input_data equals the STOPC or RESET command in any of the three bytes on DIN.

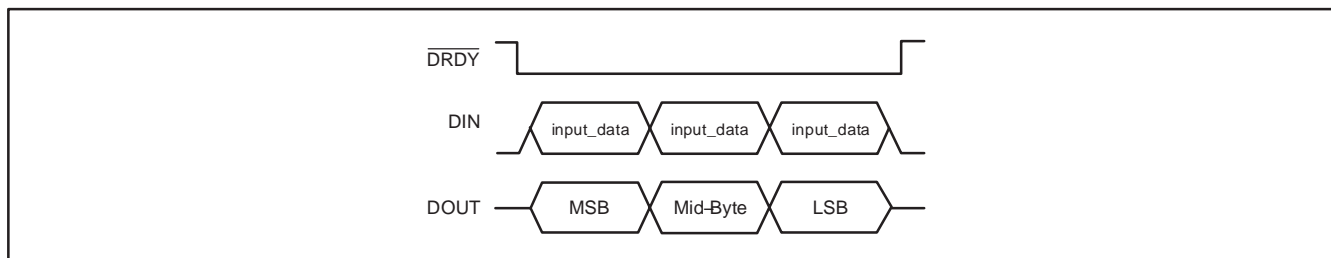

Figure 31. DIN and DOUT Command Sequence During Read Continuous Mode

STOPC: Stop Read Data Continuous

Description: Ends the continuous data output mode. (see RDATAC). The command must be issued after $\overline{\text{DRDY}}$ goes low and completed before $\overline{\text{DRDY}}$ goes high.

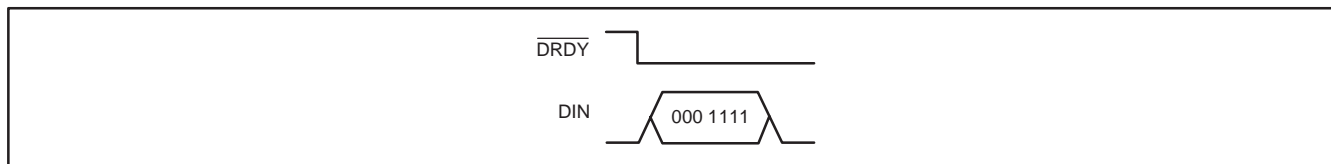

Figure 32. STOPC Command Sequence

RREG: Read from Registers

Description: Output the data from up to 11 registers starting with the register address specified as part of the command. The number of registers read will be one plus the second byte of the command. If the count exceeds the remaining registers, the addresses will wrap back to the beginning.

1st Command Byte: 0001 *rrrr* where *rrrr* is the address of the first register to read.

2nd Command Byte: 0000 *nnnn* where *nnnn* is the number of bytes to read – 1. See the Timing Characteristics for the required delay between the end of the RREG command and the beginning of shifting data on DOUT: t_6 .

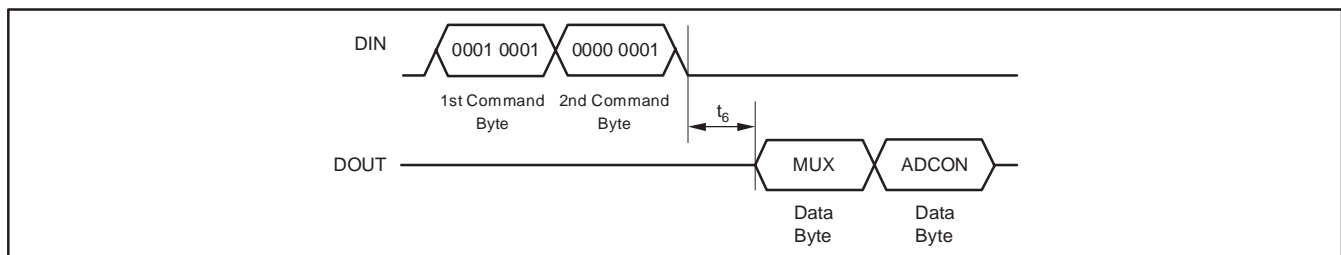

Figure 33. RREG Command Example: Read Two Registers Starting from Register 01h (multiplexer)

WREG: Write to Register

Description: Write to the registers starting with the register specified as part of the command. The number of registers that will be written is one plus the value of the second byte in the command.

1st Command Byte: 0101 *rrrr* where *rrrr* is the address to the first register to be written.

2nd Command Byte: 0000 *nnnn* where *nnnn* is the number of bytes to be written – 1.

Data Byte(s): data to be written to the registers.

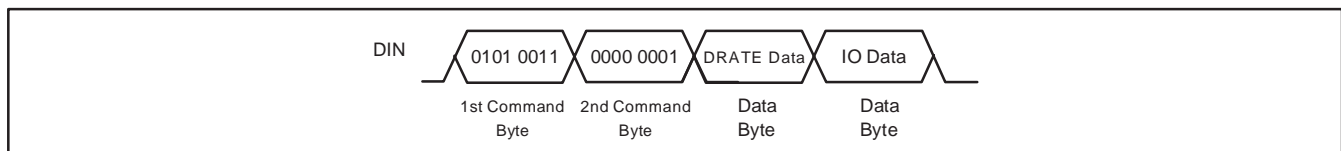

Figure 34. WREG Command Example: Write Two Registers Starting from 03h (DRATE)

SELF CAL: Self Offset and Gain Calibration

Description: Performs a self offset and self gain calibration. The Offset Calibration Register (OFC) and Full-Scale Calibration Register (FSC) are updated after this operation. \overline{DRDY} goes high at the beginning of the calibration. It goes low after the calibration completes and settled data is ready. Do not send additional commands after issuing this command until \overline{DRDY} goes low indicating that the calibration is complete.

SELF CAL: Self Offset Calibration

Description: Performs a self offset calibration. The Offset Calibration Register (OFC) is updated after this operation. \overline{DRDY} goes high at the beginning of the calibration. It goes low after the calibration completes and settled data is ready. Do not send additional commands after issuing this command until \overline{DRDY} goes low indicating that the calibration is complete.

SELF CAL: Self Gain Calibration

Description: Performs a self gain calibration. The Full-Scale Calibration Register (FSC) is updated with new values after this operation. \overline{DRDY} goes high at the beginning of the calibration. It goes low after the calibration completes and settled data is ready. Do not send additional commands after issuing this command until \overline{DRDY} goes low indicating that the calibration is complete.

SYSOCAL: System Offset Calibration

Description: Performs a system offset calibration. The Offset Calibration Register (OFC) is updated after this operation. \overline{DRDY} goes high at the beginning of the calibration. It goes low after the calibration completes and settled data is ready. Do not send additional commands after issuing this command until \overline{DRDY} goes low indicating that the calibration is complete.

SYSGCAL: System Gain Calibration

Description: Performs a system gain calibration. The Full-Scale Calibration Register (FSC) is updated after this operation. \overline{DRDY} goes high at the beginning of the calibration. It goes low after the calibration completes and settled data is ready. Do not send additional commands after issuing this command until \overline{DRDY} goes low indicating that the calibration is complete.

SYNC: Synchronize the A/D Conversion

Description: This command synchronizes the A/D conversion. To use, first shift in the command. Then shift in the WAKEUP command. Synchronization occurs on the first CLKIN rising edge after the first SCLK used to shift in the WAKEUP command.

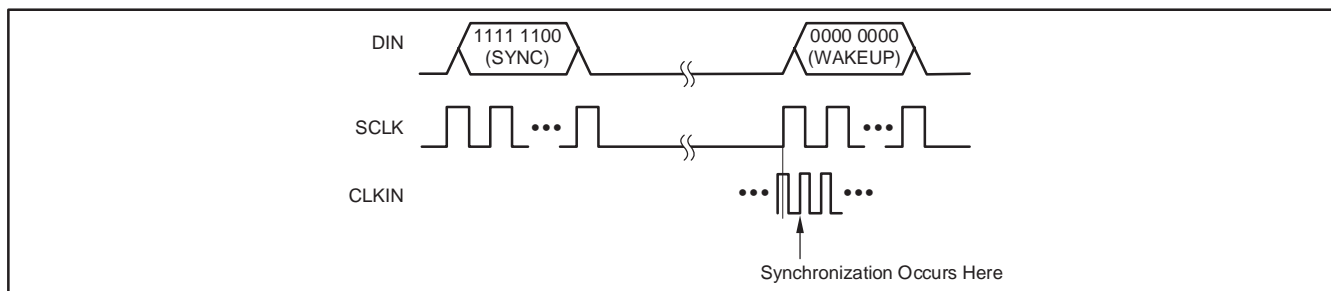

Figure 35. SYNC Command Sequence

STANDBY: Standby Mode / One-Shot Mode

Description: This command puts the ADS1255/6 into a low-power Standby mode. After issuing the STANDBY command, make sure there is no more activity on SCLK while \overline{CS} is low, as this will interrupt Standby mode. If \overline{CS} is high, SCLK activity is allowed during Standby mode. To exit Standby mode, issue the WAKEUP command. This command can also be used to perform single conversions (see One-Shot Mode section) .

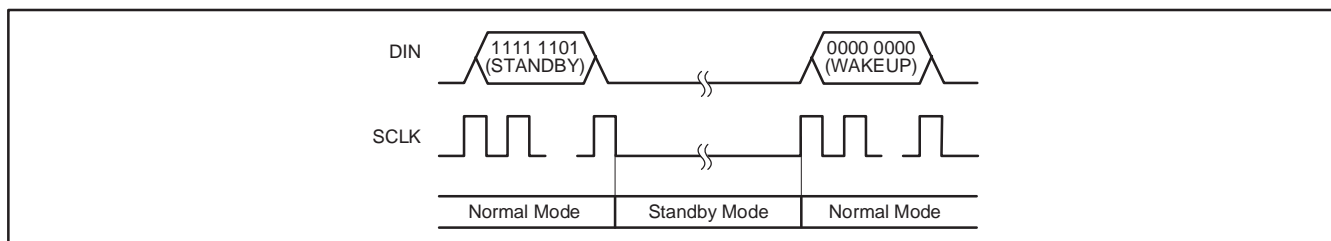

Figure 36. STANDBY Command Sequence

WAKEUP: Complete Synchronization or Exit Standby Mode

Description: Used in conjunction with the SYNC and STANDBY commands. Two values (all zeros or all ones) are available for this command.

RESET: Reset Registers to Default Values

Description: Returns all registers except the CLK0 and CLK1 bits in the ADCON register to their default values. This command will also stop the Read Continuous mode: in this case, issue the RESET command after \overline{DRDY} goes low.

DB (R-PDSO-G**)

PLASTIC SMALL-OUTLINE

28 PINS SHOWN



- NOTES: A. All linear dimensions are in millimeters.
 B. This drawing is subject to change without notice.
 C. Body dimensions do not include mold flash or protrusion not to exceed 0,15.
 D. Falls within JEDEC MO-150

IMPORTANT NOTICE

Texas Instruments Incorporated and its subsidiaries (TI) reserve the right to make corrections, modifications, enhancements, improvements, and other changes to its products and services at any time and to discontinue any product or service without notice. Customers should obtain the latest relevant information before placing orders and should verify that such information is current and complete. All products are sold subject to TI's terms and conditions of sale supplied at the time of order acknowledgment.

TI warrants performance of its hardware products to the specifications applicable at the time of sale in accordance with TI's standard warranty. Testing and other quality control techniques are used to the extent TI deems necessary to support this warranty. Except where mandated by government requirements, testing of all parameters of each product is not necessarily performed.

TI assumes no liability for applications assistance or customer product design. Customers are responsible for their products and applications using TI components. To minimize the risks associated with customer products and applications, customers should provide adequate design and operating safeguards.

TI does not warrant or represent that any license, either express or implied, is granted under any TI patent right, copyright, mask work right, or other TI intellectual property right relating to any combination, machine, or process in which TI products or services are used. Information published by TI regarding third-party products or services does not constitute a license from TI to use such products or services or a warranty or endorsement thereof. Use of such information may require a license from a third party under the patents or other intellectual property of the third party, or a license from TI under the patents or other intellectual property of TI.

Reproduction of information in TI data books or data sheets is permissible only if reproduction is without alteration and is accompanied by all associated warranties, conditions, limitations, and notices. Reproduction of this information with alteration is an unfair and deceptive business practice. TI is not responsible or liable for such altered documentation.

Resale of TI products or services with statements different from or beyond the parameters stated by TI for that product or service voids all express and any implied warranties for the associated TI product or service and is an unfair and deceptive business practice. TI is not responsible or liable for any such statements.

Following are URLs where you can obtain information on other Texas Instruments products and application solutions:

Products		Applications	
Amplifiers	amplifier.ti.com	Audio	www.ti.com/audio
Data Converters	dataconverter.ti.com	Automotive	www.ti.com/automotive
DSP	dsp.ti.com	Broadband	www.ti.com/broadband
Interface	interface.ti.com	Digital Control	www.ti.com/digitalcontrol
Logic	logic.ti.com	Military	www.ti.com/military
Power Mgmt	power.ti.com	Optical Networking	www.ti.com/opticalnetwork
Microcontrollers	microcontroller.ti.com	Security	www.ti.com/security
		Telephony	www.ti.com/telephony
		Video & Imaging	www.ti.com/video
		Wireless	www.ti.com/wireless

Mailing Address: Texas Instruments
Post Office Box 655303 Dallas, Texas 75265