



# 10-Bit Digital Temperature Sensor (AD7416) and Single/Four-Channel ADC (AD7417/AD7418)

## AD7416/AD7417/AD7418

### FEATURES

- 10-Bit ADC with 15  $\mu$ s and 30  $\mu$ s Conversion Times
- Single and Four Single-Ended Analog Input Channels
- On-Chip Temperature Sensor:  $-55^{\circ}\text{C}$  to  $+125^{\circ}\text{C}$
- On-Chip Track/Hold
- Over-Temperature Indicator
- Automatic Power Down at the End of a Conversion
- Wide Operating Supply Range:  $+2.7\text{ V}$  to  $+5.5\text{ V}$
- I<sup>2</sup>C<sup>®</sup> Compatible Serial Interface
- Selectable Serial Bus Address Allows Connection of Up to Eight AD7416/AD7417s to a Single Bus
- AD7416 is a Superior Replacement for LM75

### APPLICATIONS

- Data Acquisition with Ambient Temperature Monitoring
- Industrial Process Control
- Automotive
- Battery Charging Applications
- Personal Computers

### GENERAL DESCRIPTION

The AD7417 and AD7418 are 10-bit, single- and 4-channel A/D converter with an on-chip temperature sensor that can operate from a single  $+2.7\text{ V}$  to  $+5.5\text{ V}$  power supply. The devices contain a 15  $\mu$ s successive-approximation converter, a 5-channel multiplexer, a temperature sensor, a clock oscillator, a track/hold, and a reference ( $+2.5\text{ V}$ ). The AD7416 is a temperature-monitoring-only device in an 8-lead package.

The temperature sensor on the parts can be accessed via multiplexer Channel 0. When Channel 0 is selected and a conversion is initiated, the resulting ADC code at the end of the conversion gives a measurement of the ambient temperature ( $\pm 1^{\circ}\text{C}$  @  $+25^{\circ}\text{C}$ ). On-chip registers can be programmed with high and low temperature limits, and an open drain Over-Temperature Indicator output (OTI) is provided, which becomes active when a programmed limit is exceeded.

A configuration register allows programming of the sense of the OTI output (active high or active low) and its operating mode (comparator or interrupt). A programmable fault queue counter allows the number of out of limit measurements that must occur before triggering the OTI output to be set, to prevent spurious triggering of the OTI output in noisy environments.

(continued on page 7)

I<sup>2</sup>C is a registered trademark of Philips Corporation.

### REV. A

Information furnished by Analog Devices is believed to be accurate and reliable. However, no responsibility is assumed by Analog Devices for its use, nor for any infringements of patents or other rights of third parties which may result from its use. No license is granted by implication or otherwise under any patent or patent rights of Analog Devices.

### FUNCTIONAL BLOCK DIAGRAMS

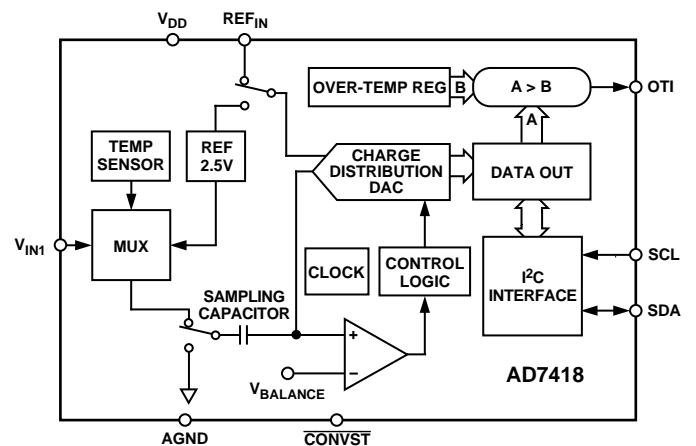
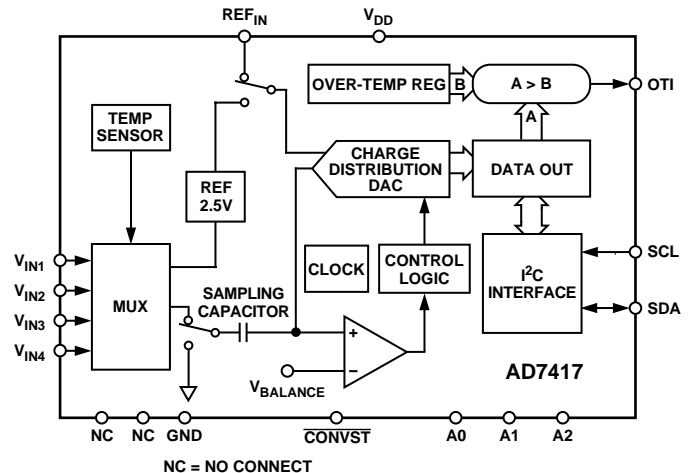
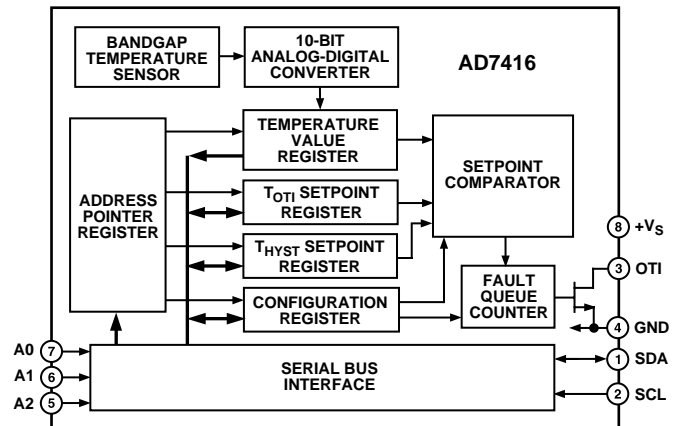

# AD7416/AD7417/AD7418

## AD7417/AD7418—SPECIFICATIONS ( $V_{DD} = +2.7\text{ V}$ to $+5.5\text{ V}$ , $GND = 0\text{ V}$ , $REF_{IN} = +2.5\text{ V}$ , unless otherwise noted)

Parameter	A Version	B Version <sup>1</sup>	Units	Test Conditions/Comments
<b>DC ACCURACY</b>				Any Channel
Resolution	10	10	Bits	
Minimum Resolution for Which No Missing Codes are Guaranteed	10	10	Bits	
Relative Accuracy <sup>2</sup>	±1	±1	LSB max	This Spec Is Typical for $V_{DD}$ of +3.6 V to +5.5 V
Differential Nonlinearity <sup>2</sup>	±1	±1	LSB max	This Spec Is Typical for $V_{DD}$ of +3.6 V to +5.5 V
Gain Error <sup>2</sup>	±3	±3	LSB max	External Reference
	±10	±10	LSB max	Internal Reference
Gain Error Match <sup>2</sup>	±0.6	±0.6	LSB max	AD7417 Only
Offset Error <sup>2</sup>	±4	±4	LSB max	
Offset Error Match	±0.7	±0.7	LSB max	AD7417 Only
<b>ANALOG INPUTS</b>				
Input Voltage Range	$V_{REF}$ 0	$V_{REF}$ 0	V max V min	
Input Leakage Current <sup>3</sup>	±1	±1	μA max	
Input Capacitance	10	10	pF max	
<b>TEMPERATURE SENSOR<sup>1</sup></b>				
Measurement Error				
Ambient Temperature +25°C	±2	±1	°C max	
$T_{MIN}$ to $T_{MAX}$	±3	±2	°C max	
Temperature Resolution	1/4	1/4	°C/LSB	
<b>CONVERSION RATE</b>				
Track/Hold Acquisition Time <sup>4</sup>	400	400	ns max	Source Impedance < 10 Ω
Conversion Time				
Temperature Sensor	30	30	μs max	
Channels 1 to 4	15	15	μs max	
<b>REFERENCE INPUT<sup>5,6</sup></b>				
$REF_{IN}$ Input Voltage Range <sup>6</sup>	2.625 2.375	2.625 2.375	V max V min	2.5 V + 5% 2.5 V – 5%
Input Impedance	40	40	kΩ min	
Input Capacitance	10	10	pF max	
<b>ON-CHIP REFERENCE</b>				Nominal 2.5 V
Reference Error <sup>6</sup>	±25	±25	mV max	
Temperature Coefficient <sup>6</sup>	80	80	ppm/°C typ	
<b>DIGITAL INPUTS</b>				
Input High Voltage, $V_{IH}$	$+V_S \times 0.7$	$+V_S \times 0.7$	V min	
Input Low Voltage, $V_{IL}$	$+V_S \times 0.3$	$+V_S \times 0.3$	V max	
Input Leakage Current	1	1	μA max	
<b>DIGITAL OUTPUTS</b>				
Output Low Voltage, $V_{OL}$	0.4	0.4	V max	$I_{OL} = 3\ \mu\text{A}$
Output High Current	1	1	μA max	$V_{OH} = 5\text{ V}$
<b>POWER REQUIREMENTS</b>				
$V_{DD}$	+5.5 +2.7	+5.5 +2.7	V max V min	For Specified Performance
$I_{DD}$ <sup>7</sup>				Logic Inputs = 0 V or $V_{DD}$
Normal Operation	600	600	μA max	
Power Down	1	1	μA max	50 nA Typically
Auto Power-Down Mode				$V_{DD} = 3\text{ V}$ . See Operating Modes
10 sps Throughput Rate	6	6	μW typ	
1 ksp/s Throughput Rate	60	60	μW typ	
10 ksp/s Throughput Rate	600	600	μW typ	
Power Down	3	3	μW max	Typically 0.15 μW

**NOTES**

<sup>1</sup>B version applies to AD7417 only with temperature range of  $-40^{\circ}\text{C}$  to  $+85^{\circ}\text{C}$ . A version temperature range is  $-55^{\circ}\text{C}$  to  $+125^{\circ}\text{C}$ . For  $V_{\text{DD}} = +2.7\text{ V}$ ,  $T_{\text{A}} = +85^{\circ}\text{C}$  max and temperature sensor measurement error =  $\pm 3^{\circ}\text{C}$ .

<sup>2</sup>See Terminology.

<sup>3</sup>Refers to the input current when the part is not converting. Primarily due to reverse leakage current in the ESD protection diodes.

<sup>4</sup>Sample tested during initial release and after any redesign or process change that may affect this parameter.

<sup>5</sup>On-chip reference shuts down when external reference is applied.

<sup>6</sup>The accuracy of the temperature sensor is affected by reference tolerance. The relationship between the two is explained in the section titled Temperature Sensor.

<sup>7</sup>The AD7417 and AD7418  $I_{\text{DD}}$  is typically 1 mA when the parts are set for external CONVST Mode and CONVST is held high.

Specifications subject to change without notice.

## AD7416—SPECIFICATIONS ( $V_{\text{DD}} = +2.7\text{ V}$ to $+5.5\text{ V}$ , $\text{GND} = 0\text{ V}$ , $\text{REF}_{\text{IN}} = +2.5\text{ V}$ , unless otherwise noted)

Parameter	Min	Typ	Max	Units	Test Conditions/Comments
<b>TEMPERATURE SENSOR AND ADC</b>					
Accuracy			$\pm 2.0$ $\pm 3.0$	$^{\circ}\text{C}$ $^{\circ}\text{C}$	$T_{\text{A}} = -25^{\circ}\text{C}$ to $+100^{\circ}\text{C}$ ( $V_{\text{DD}} = 3\text{ V min}$ ) <sup>1</sup> $T_{\text{A}} = -55^{\circ}\text{C}$ to $+125^{\circ}\text{C}$ ( $V_{\text{DD}} = 3\text{ V min}$ ) <sup>1</sup>
Resolution		10		Bits	
Temperature Conversion Time			40	$\mu\text{s}$	
Update Rate, $t_{\text{R}}$		400		$\mu\text{s}$	
OTI Delay	$1 \times t_{\text{R}}$		$6 \times t_{\text{R}}$	ms	Depends on Fault Queue Setting
Supply Current			1.0	mA	I <sup>2</sup> C Active
			350	$\mu\text{A}$	I <sup>2</sup> C Inactive
			0.2	$\mu\text{A}$	Shutdown Mode
			1.5	$\mu\text{A}$	
$T_{\text{OTI}}$ Default Temperature		80		$^{\circ}\text{C}$	
$T_{\text{HYST}}$ Default Temperature		75		$^{\circ}\text{C}$	
<b>DIGITAL INPUTS</b>					
Input High Voltage, $V_{\text{IH}}$	$+V_{\text{S}} \times 0.7$		$+V_{\text{S}} + 0.5$	V	
Input Low Voltage, $V_{\text{IL}}$	$-0.3$		$+V_{\text{S}} \times 0.3$	V	
Input High Current, $I_{\text{IH}}$		0.005	1.0	$\mu\text{A}$	$V_{\text{IN}} = 5\text{ V}$
Input Low Current, $I_{\text{IL}}$		$-0.005$	$-1.0$	$\mu\text{A}$	$V_{\text{IN}} = 0\text{ V}$
Input Capacitance, $C_{\text{IN}}$		20		pF	All Digital Inputs
<b>DIGITAL OUTPUTS</b>					
Output Low Voltage, $V_{\text{OL}}$			0.4	V	I <sub>OL</sub> = 3 mA
Output High Current			1	mA	V <sub>OH</sub> = 5 V
Output Fall Time, $t_{\text{f}}$			250	ns	C <sub>L</sub> = 400 pF, I <sub>O</sub> = 3 mA
OS Output Low Voltage, $V_{\text{OL}}$			0.8	V	I <sub>OUT</sub> = 4 mA
<b>AC ELECTRICAL CHARACTERISTICS<sup>2</sup></b>					
Serial Clock Period, $t_1$			2.5	$\mu\text{s}$	AD7416/AD7417/AD7418 See Figure 1
Data In Setup Time to SCL High, $t_2$	50			ns	See Figure 1
Data Out Stable after SCL Low, $t_3$	0			ns	See Figure 1
SDA Low Setup Time to SCL Low (Start Condition), $t_4$	50			ns	See Figure 1
SDA High Hold Time after SCL High (Stop Condition), $t_5$	50			ns	See Figure 1
SDA and SCL Fall Time, $t_6$			90	ns	See Figure 1

**NOTES**

<sup>1</sup>For  $V_{\text{DD}} = 2.7\text{ V}$  to  $3\text{ V}$ ,  $T_{\text{A}} \text{ max} = +85^{\circ}\text{C}$  and accuracy =  $\pm 3^{\circ}\text{C}$ .

<sup>2</sup>Sample tested during initial release and after any redesign or process change that may affect this parameter.

Specifications subject to change without notice.

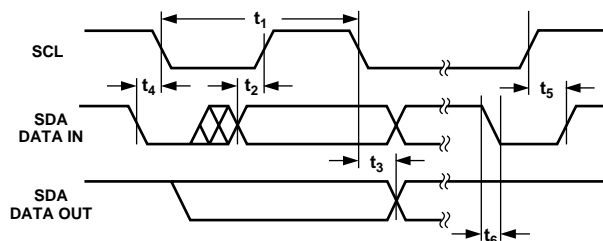

Figure 1. Diagram for Serial Bus Timing

# AD7416/AD7417/AD7418

## AD7417 PIN FUNCTION DESCRIPTION

Pin No.	Mnemonic	Description
1, 16	NC	No Connection. Do not connect anything to this pin.
2	SDA	Digital I/O. Serial Bus Bidirectional Data. Push-pull output.
3	SCL	Digital Input. Serial Bus Clock.
4	OTI	This is a logic output. The Over Temperature Indicator (OTI) is set if the result of a conversion on Channel 0 (temperature sensor) is greater than an 8-bit word in the Over Temperature Register (OTR). The signal is reset at the end of a serial read operation. Open-drain output.
5	REF <sub>IN</sub>	Reference Input. An external 2.5 V reference can be connected to the AD7417 at this pin. To enable the on-chip reference the REF <sub>IN</sub> pin should be tied to GND. If an external reference is connected to the AD7417, the internal reference will shut down.
6	GND	Ground Reference for Track/Hold, Comparator and Capacitor DAC, and Digital Circuitry.
7–10	A <sub>IN1</sub> to A <sub>IN4</sub>	Analog Input Channels. The AD7417 has four analog input channels. The input channels are single-ended with respect to GND. The input channels can convert voltage signals in the range 0 V to V <sub>REF</sub> . A channel is selected by writing to the configuration register of the AD7417. (See Control Byte section.)
11	A2	Digital Input. The highest programmable bit of the Serial Bus Address.
12	A1	Digital Input. The middle programmable bit of the Serial Bus Address.
13	A0	Digital Input. The lowest programmable bit of the Serial Bus Address.
14	V <sub>DD</sub>	Positive Supply Voltage, +2.7 V to +5.5 V.
15	CONVST	Logic Input Signal. Convert Start Signal. The rising edge of this signal fully powers up the part. The power-up time for the part is 4 μs. If the CONVST pulse is greater than 4 μs, the falling edge of CONVST places the track/hold mode into hold mode and initiates a conversion. If the pulse is less than 4 μs, an internal timer ensures that the track/hold does not go into hold and conversion is not initiated until the power-up time has elapsed. The track/hold goes into track mode again at the end of conversion. (See Operating Mode section.)

## AD7417 PIN CONFIGURATION SOIC/TSSOP

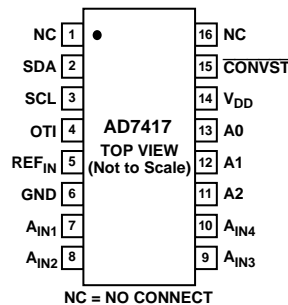

## AD7416 PIN FUNCTION DESCRIPTION

Pin No.	Mnemonic	Description
1	SDA	Digital I/O. Serial Bus Bidirectional Data. Push-pull output.
2	SCL	Digital Input. Serial Bus Clock.
3	OTI	This is a logic output. The Over-Temperature Indicator (OTI) is set if the result of a conversion on Channel 0 (Temperature Sensor) is greater than an 8-bit word in the Over-Temperature Register (OTR). The signal is reset at the end of a serial read operation. Open-drain output.
4	GND	Ground reference for track/hold, comparator and capacitor DAC, and digital circuitry.
5	A2	Digital Input. The highest programmable bit of the Serial Bus Address.
6	A1	Digital Input. The middle programmable bit of the Serial Bus Address.
7	A0	Digital Input. The lowest programmable bit of the Serial Bus Address.
8	V <sub>DD</sub>	Positive Supply Voltage, +2.7 V to +5.5 V.

## AD7418 PIN FUNCTION DESCRIPTION

Pin No.	Mnemonic	Description
1	SDA	Digital I/O. Serial Bus Bidirectional Data. Push-pull output.
2	SCL	Digital Input. Serial Bus Clock.
3	OTI	This is a logic output. The Over-Temperature Indicator (OTI) is set if the result of a conversion on Channel 0 (Temperature Sensor) is greater than an 8-bit word in the Over-Temperature Register (OTR). The signal is reset at the end of a serial read operation. Open-drain output.
4	GND	Ground reference for track/hold, comparator and capacitor DAC, and digital circuitry.
5	A <sub>IN</sub>	Analog Input Channel. The input channel is single-ended with respect to GND. The input channel can convert voltage signals in the range 0 V to V <sub>REF</sub> . The analog input channel is selected by writing to the configuration register of the AD7418 and choosing Channel 4. (See Control Byte section.)
6	REF <sub>IN</sub>	Reference Input. An external 2.5 V reference can be connected to the AD7418 at this pin. To enable the on-chip reference the REF <sub>IN</sub> pin should be tied to GND. If an external reference is connected to the AD7418, the internal reference will shut down.
7	V <sub>DD</sub>	Positive Supply Voltage, +2.7 V to +5.5 V.
8	CONVST	Logic Input Signal. Convert Start Signal. The rising edge of this signal fully powers up the part. The power-up time for the part is 4 μs. If the CONVST pulse is greater than 4 μs, the falling edge of CONVST places the track/hold mode into hold mode and initiates a conversion. If the pulse is less than 4 μs, an internal timer ensures that the track/hold does not go into hold and conversion is not initiated until the power-up time has elapsed. The track/hold goes into track mode again at the end of conversion. (See Operating Mode section.)

**AD7416 PIN CONFIGURATION**  
SOIC/μSOIC

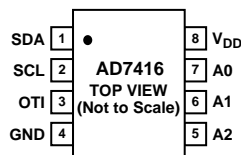

**AD7418 PIN CONFIGURATION**  
SOIC/μSOIC

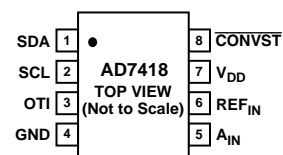

# AD7416/AD7417/AD7418

## ABSOLUTE MAXIMUM RATINGS<sup>1</sup>

(T<sub>A</sub> = +25°C unless otherwise noted)

V <sub>DD</sub> to AGND	−0.3 V to +7 V
V <sub>DD</sub> to DGND	−0.3 V to +7 V
Analog Input Voltage to AGND	
A <sub>IN1</sub> to A <sub>IN4</sub>	−0.3 V to V <sub>DD</sub> + 0.3 V
Reference Input Voltage to AGND <sup>2</sup>	−0.3 V to V <sub>DD</sub> + 0.3 V
Digital Input Voltage to DGND	−0.3 V to V <sub>DD</sub> + 0.3 V
Digital Output Voltage to DGND	−0.3 V to V <sub>DD</sub> + 0.3 V
Operating Temperature Range	
A Version	−55°C to +125°C
B Version	−40°C to +85°C
Storage Temperature Range	
Junction Temperature	−65°C to +150°C
TSSOP, Power Dissipation	
θ <sub>JA</sub> Thermal Impedance	120°C/W
Lead Temperature, Soldering	+260°C
Vapor Phase (60 sec)	+215°C
Infrared (15 sec)	+220°C
16-Lead SOIC Package, Power Dissipation	
θ <sub>JA</sub> Thermal Impedance	100°C/W
Lead Temperature, Soldering	
Vapor Phase (60 sec)	+215°C
Infrared (15 sec)	+220°C

8-Lead SOIC Package, Power Dissipation	450 mW
θ <sub>JA</sub> Thermal Impedance	157°C/W
Lead Temperature, Soldering	
Vapor Phase (60 sec)	+215°C
Infrared (15 sec)	+220°C
μSOIC Package, Power Dissipation	
θ <sub>JA</sub> Thermal Impedance	206°C/W
Lead Temperature, Soldering	
Vapor Phase (60 sec)	+215°C
Infrared (15 sec)	+220°C

## NOTES

<sup>1</sup>Stresses above those listed under Absolute Maximum Ratings may cause permanent damage to the device. This is a stress rating only; functional operation of the device at these or any other conditions above those listed in the operational sections of this specification is not implied. Exposure to absolute maximum rating conditions for extended periods may affect device reliability.

<sup>2</sup>If the Reference Input Voltage is likely to exceed V<sub>DD</sub> by more than 0.3 V (e.g., during power-up) and the reference is capable of supplying 30 mA or more, it is recommended to use a clamping diode between the REF<sub>IN</sub> pin and V<sub>DD</sub> pin. The diagram below shows how the diode should be connected.

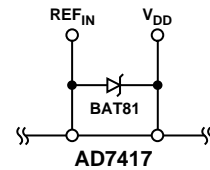

## ORDERING GUIDE

Model	Temperature Range	Temperature Error @ +25°C	Package Description	Branding Information	Package Options
AD7416AR	−55°C to +125°C	±2°C	8-Lead Narrow Body (SOIC)	C6A	SO-8
AD7416ARM	−55°C to +125°C	±2°C	8-Lead μSOIC		RM-8
AD7417AR	−55°C to +125°C	±2°C	16-Lead Narrow Body (SOIC)		R-16A
AD7417ARU	−55°C to +125°C	±2°C	16-Lead (TSSOP)		RU-16
AD7417BR	−40°C to +85°C	±1°C	16-Lead Narrow Body (SOIC)		R-16A
AD7418AR	−55°C to +125°C	±2°C	8-Lead Narrow Body (SOIC)		SO-8
AD7418ARM	−55°C to +125°C	±2°C	8-Lead μSOIC	C7A	RM-8

## CAUTION

ESD (electrostatic discharge) sensitive device. Electrostatic charges as high as 4000 V readily accumulate on the human body and test equipment and can discharge without detection. Although the AD7416/AD7417/AD7418 features proprietary ESD protection circuitry, permanent damage may occur on devices subjected to high energy electrostatic discharges. Therefore, proper ESD precautions are recommended to avoid performance degradation or loss of functionality.



(continued from page 1)

An I<sup>2</sup>C-compatible serial interface allows the AD7416/AD7417/AD7418 registers to be written to and read back. The 3 LSBs of the AD7416/AD7417's serial bus address can be selected, which allows up to eight AD7416/AD7417s to be connected to a single bus.

The AD7417 is available in a narrow body 0.15" 16-lead small outline IC (SOIC) and in a 16-lead, thin shrink small outline package (TSSOP). The AD7416 and AD7418 are available in 8-lead SOIC and  $\mu$ SOIC packages.

#### PRODUCT HIGHLIGHTS

1. The AD7416/AD7417/AD7418 have an on-chip temperature sensor that allows an accurate measurement of the ambient temperature ( $\pm 1^\circ\text{C}$  @  $+25^\circ\text{C}$ ,  $\pm 2^\circ\text{C}$  over temperature) to be made. The measurable temperature range is  $-55^\circ\text{C}$  to  $+125^\circ\text{C}$ . An over-temperature indicator is implemented by carrying out a digital comparison of the ADC code for Channel 0 (temperature sensor) with the contents of the on-chip over-temperature register.
2. The AD7417 offers a space saving 10-bit A/D solution with four external voltage input channels, an on-chip temperature sensor, an on-chip reference and clock oscillator.
3. The automatic power-down feature enables the AD7416/AD7417/AD7418 to achieve superior power performance. At slower throughput rates the part can be programmed to operate in a low power shutdown mode allowing further savings in power consumption.

#### TERMINOLOGY

##### Relative Accuracy

Relative accuracy or endpoint nonlinearity is the maximum deviation from a straight line passing through the endpoints of the ADC transfer function.

##### Differential Nonlinearity

This is the difference between the measured and the ideal 1 LSB change between any two adjacent codes in the ADC.

##### Offset Error

This is the deviation of the first code transition (0000 . . . 000) to (0000 . . . 001) from the ideal, i.e., GND + 1 LSB.

##### Offset Error Match

This is the difference in Offset Error between any two channels.

##### Gain Error

This is the deviation of the last code transition (1111 . . . 110) to (1111 . . . 111) from the ideal, i.e., VREF – 1 LSB, after the offset error has been adjusted out.

##### Gain Error Match

This is the difference in gain error between any two channels.

##### Track/Hold Acquisition Time

Track/hold acquisition time is the time required for the output of the track/hold amplifier to reach its final value, within  $\pm 1/2$  LSB, after the end of conversion (the point at which the track/hold returns to track mode). It also applies to situations where a change in the selected input channel takes place or where there is a step input change on the input voltage applied to the selected  $A_{IN}$  input of the AD7417 or AD7418. It means that the user must wait for the duration of the track/hold acquisition time after the end of conversion or after a channel change/step input change to  $A_{IN}$  before starting another conversion, to ensure that the part operates to specification.

# AD7416/AD7417/AD7418

## CIRCUIT INFORMATION

The AD7417 and AD7418 are single- and four-channel, 15  $\mu$ s conversion time, 10-bit A/D converters with on-chip temperature sensor, reference and serial interface logic functions on a single chip. The AD7416 has no analog input channel and is intended for temperature measurement only. The A/D converter section consists of a conventional successive-approximation converter based around a capacitor DAC. The AD7416, AD7417 and AD7418 are capable of running on a 2.7 V to 5.5 V power supply and the AD7417 and AD7418 accept an analog input range of 0 V to +VREF. The on-chip temperature sensor allows an accurate measurement of the ambient device temperature to be made. The working measurement range of the temperature sensor is  $-55^{\circ}\text{C}$  to  $+125^{\circ}\text{C}$ . The parts require a +2.5 V reference which can be provided from the part's own internal reference or from an external reference source.

## CONVERTER DETAILS

Conversion is initiated on the AD7417/AD7418 by pulsing the CONVST input. The conversion clock for the part is internally generated so no external clock is required except when reading from and writing to the serial port. The on-chip track/hold goes from track to hold mode and the conversion sequence is started on the falling edge of the CONVST signal. A conversion is also initiated in the automatic conversion mode every time a read or write operation to the AD7416/AD7417/AD7418 takes place. In this case, the internal clock oscillator (which runs the automatic conversion sequence) is restarted at the end of the read or write operation. The track/hold goes into hold approximately 3  $\mu$ s after the read or write operation is complete and a conversion is then initiated. The result of the conversion is available either 15  $\mu$ s or 30  $\mu$ s later, depending on whether an analog input channel or the temperature sensor is selected. The track/hold acquisition time of the AD7417/AD7418 is 400 ns.

A temperature measurement is made by selecting the Channel 0 of the on-chip MUX and carrying out a conversion on this channel. A conversion on Channel 0 takes 30  $\mu$ s to complete. Temperature measurement is explained in the Temperature Measurement section of this data sheet.

The on-chip reference is not available to the user, but REF<sub>IN</sub> can be overdriven by an external reference source (+2.5 V only). The effect of reference tolerances on temperature measurements is discussed in the Reference section of the data sheet.

All unused analog inputs should be tied to a voltage within the nominal analog input range to avoid noise pickup. For minimum power consumption, the unused analog inputs should be tied to GND.

## TYPICAL CONNECTION DIAGRAM

Figure 2 shows a typical connection diagram for the AD7417. Using the A0, A1 and A2 pins allows the user to select from up to eight AD7417s on the same serial bus, if desired. An external 2.5 V reference can be connected at the REF<sub>IN</sub> pin. If an external reference is used, a 10  $\mu$ F capacitor should be connected between REF<sub>IN</sub> and GND. SDA and SCL form the two-wire I<sup>2</sup>C-compatible interface. For applications where power consumption is of concern, the automatic power-down at the end of a conversion should be used to improve power performance. See Operating Modes section of the data sheet.

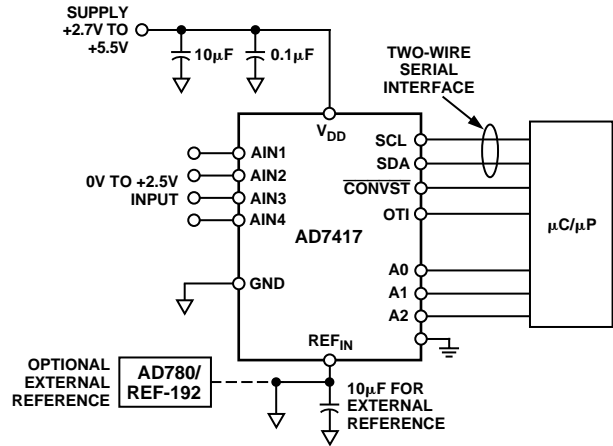

Figure 2. Typical Connection Diagram

## ANALOG INPUTS

Figure 3 shows an equivalent circuit of the analog input structure of the AD7417 and AD7418. The two diodes, D1 and D2, provide ESD protection for the analog inputs. Care must be taken to ensure that the analog input signal never exceeds the supply rails by more than 200 mV. This will cause these diodes to become forward-biased and start conducting current into the substrate. The maximum current these diodes can conduct without causing irreversible damage to the part, is 20 mA. The capacitor C2 in Figure 3 is typically about 4 pF and can primarily be attributed to pin capacitance. The resistor R1 is a lumped component made up of the on resistance of a multiplexer and a switch. This resistor is typically about 1 k $\Omega$ . The capacitor C1 is the ADC sampling capacitor and has a capacitance of 3 pF.

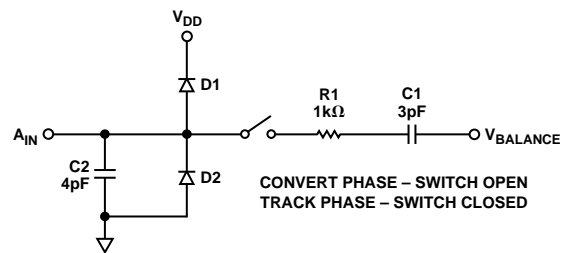

Figure 3. Equivalent Analog Input Circuit

## ON-CHIP REFERENCE

The AD7416/AD7417/AD7418 has an on-chip 1.2 V band-gap reference which is gained up by a switched capacitor amplifier to give an output of 2.5 V. The amplifier is only powered up at the start of the conversion phase and is powered down at the end of the conversion. The on-chip reference is selected by connecting the REF<sub>IN</sub> pin to analog ground. This causes SW1—(see Figure 4) to open and the reference amplifier to power up during a conversion. Therefore the on-chip reference is not available externally. An external 2.5 V reference can be connected to the REF<sub>IN</sub> pin. This has the effect of shutting down the on-chip reference circuitry.



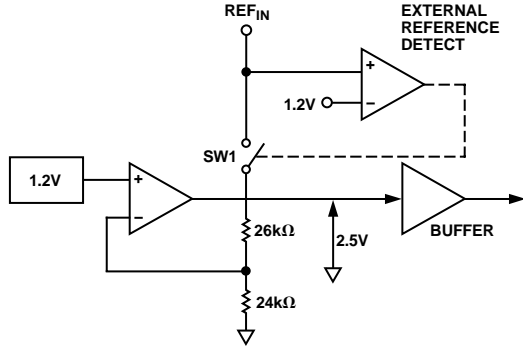

Figure 4. On-Chip Reference

### INTERNAL REGISTER STRUCTURE

The AD7417/AD7418 has seven internal registers, as shown in Figure 5. Six of these are data registers and one is an address pointer register. The AD7416 has five internal registers (the ADC and Config2 registers are not applicable to the AD7416).

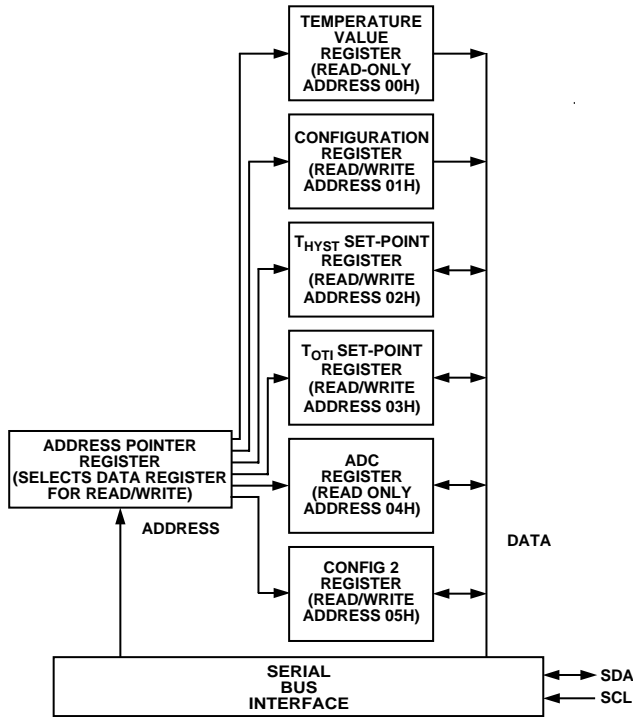

Figure 5. AD7417/AD7418 Register Structure

### ADDRESS POINTER REGISTER

The Address Pointer Register is an 8-bit register which stores an address that points to one of the six data registers. The first data byte of every serial write operation to the AD7416/AD7417/AD7418 is the address of one of the data registers, which is stored in the Address Pointer Register, and selects the data register to which subsequent data bytes are written. Only the three LSBs of this register are used to select a data register.

Table I. Address Pointer Register

P7*	P6*	P5*	P4*	P3*	P2	P1	P0
0	0	0	0	0	Register Select		

\*P3 to P7 must be set to 0.

Table II. Register Addresses

P2	P1	P0	Registers
0	0	0	Temperature Value (Read Only)
0	0	1	Config Register (Read/Write)
0	1	0	T <sub>HYST</sub> (Read/Write)
0	1	1	T <sub>OTI</sub>
1	0	0	ADC (AD7417/AD7418 Only)
1	0	1	Config2 (AD7417/AD7418 Only)

### TEMPERATURE VALUE REGISTER (ADDRESS 00H)

The temperature value register is a 16-bit, read-only register whose 10 MSBs store the temperature reading from the ADC in 10-bit twos complement format. Bits 5 to 0 are unused.

Table III. Temperature Value Register

D15	D14	D13	D12	D11	D10	D9	D8	D7	D6
MSB	B8	B7	B6	B5	B4	B3	B2	B1	LSB

The temperature data format is shown in Table IV. This shows the full theoretical range of the ADC from  $-128^{\circ}\text{C}$  to  $+127^{\circ}\text{C}$ , but in practice the temperature measurement range is limited to the operating temperature range of the device.

Table IV. Temperature Data Format

Temperature	Digital Output
$-128^{\circ}\text{C}$	10 0000 0000
$-125^{\circ}\text{C}$	10 0000 1100
$-100^{\circ}\text{C}$	10 0111 0000
$-75^{\circ}\text{C}$	10 1101 0100
$-50^{\circ}\text{C}$	11 0011 1000
$-25^{\circ}\text{C}$	11 1001 1100
$-0.25^{\circ}\text{C}$	11 1111 1111
$0^{\circ}\text{C}$	00 0000 0000
$+0.25^{\circ}\text{C}$	00 0000 0001
$+10^{\circ}\text{C}$	00 0010 1000
$+25^{\circ}\text{C}$	00 0110 0100
$+50^{\circ}\text{C}$	00 1100 1000
$+75^{\circ}\text{C}$	01 0010 1100
$+100^{\circ}\text{C}$	01 1001 0000
$+125^{\circ}\text{C}$	01 1111 0100
$+127^{\circ}\text{C}$	01 1111 1100

### CONFIGURATION REGISTER (ADDRESS 01H)

The Configuration Register is an 8-bit, read/write register that is used to set the operating modes of the AD7416/AD7417/AD7418. Bits D7 to D5 control the channel selection as outlined in Table VI. These bits should always be 0,0,0 for the AD7416. Bits D4 and D3 are used to set the length of the fault queue. D2 sets the sense of the OTI output. D1 selects comparator or interrupt mode of operation, and D0 selects shutdown mode.

Table V. Configuration Register

D7	D6	D5	D4	D3	D2	D1	D0
Channel Selection			Fault Queue		OTI Polarity	Cmp/Int	Shut-down

# AD7416/AD7417/AD7418

The AD7416 contains a temperature-only channel, the AD7417 has four analog input channels and a temperature channel, while the AD7418 has two channels, a temperature channel and an analog input channel. The temperature channel address for all parts is the same, CH0. The address for the analog input channel on the AD7418 is CH4. Table VI outlines the channel selection on the parts, while Table VII shows the fault queue settings.

**Table VI. Channel Selection**

D7	D6	D5	Channel Selection
0	0	0	Temperature Sensor (All Parts)
0	0	1	AIN1 (AD7417 Only)
0	1	0	AIN2 (AD7417 Only)
0	1	1	AIN3 (AD7417 Only)
1	0	0	AIN4 (AD7417) and AIN (AD7418)

**Table VII. Fault Queue Settings**

D4	D3	Number of Faults
0	0	1 (Power Up Default)
0	1	2
1	0	4
1	1	6

## T<sub>HYST</sub> SETPOINT REGISTER (ADDRESS 02H)

The T<sub>HYST</sub> Setpoint Register is a 16-bit, read/write register whose 9 MSBs store the T<sub>HYST</sub> setpoint in twos complement format equivalent to the 9 MSBs of the temperature value register. Bits 6 to 0 are unused.

## T<sub>OTI</sub> SETPOINT REGISTER (ADDRESS 03H)

The T<sub>OTI</sub> Setpoint Register is a 16-bit, read/write register whose 9 MSBs store the T<sub>OTI</sub> setpoint in twos complement format equivalent to the 9 MSBs of the temperature value register. Bits 6 to 0 are unused.

**Table VIII. Setpoint Registers**

D15	D14	D13	D12	D11	D10	D9	D8	D7
MSB	B7	B6	B5	B4	B3	B2	B1	LSB

## ADC VALUE REGISTER (ADDRESS 04H)

The ADC value register is a 16-bit, read only register whose 10 MSBs store the value produced by the ADC in binary format. Bits 5 to 0 are unused. Table IX shows the ADC value register with 10 MSBs containing the ADC conversion request.

**Table IX.**

D15	D14	D13	D12	D11	D10	D9	D8	D7	D6
MSB	B8	B7	B6	B5	B4	B3	B2	B1	LSB

## ADC Transfer Function

The designed code transitions occur at successive integer LSB values (i.e., 1 LSB, 2 LSB, etc.). The LSB size is = REF/1024. The ideal transfer function characteristic for the AD7417 and AD7418 ADC is shown in Figure 6.

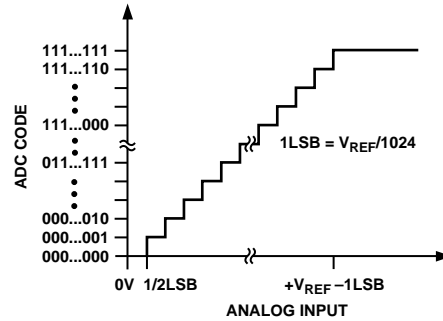

**Figure 6.**

## CONFIG2 REGISTER (ADDRESS 05H)

A second configuration register is included in the AD7417/AD7418 for the functionality of the  $\overline{\text{CONVST}}$  pin. It is an 8 bit register with bits D5 to D0 being left at 0. Bit D7 determines whether the AD7417/AD7418 should be operated in its default mode (D7 = 0), performing conversions every 355  $\mu\text{s}$  or in  $\overline{\text{CONVST}}$  pin mode (D7 = 1), where conversions will start only when the  $\overline{\text{CONVST}}$  pin is used. Bit 6 contains the Test 1 bit. When this bit is 0 the I<sup>2</sup>C filters are enabled (default). A 1 disables the filters.

**Table X.**

D7	D6	D5	D4	D3	D2	D1	D0
Conversion Mode	Test 1	0	0	0	0	0	0

## SERIAL BUS INTERFACE

Control of the AD7416/AD7417/AD7418 is carried out via the I<sup>2</sup>C-compatible serial bus. The AD7416/AD7417/AD7418 is connected to this bus as a slave device, under the control of a master device, e.g., the processor.

## SERIAL BUS ADDRESS

As with all I<sup>2</sup>C-compatible devices, the AD7416/AD7417/AD7418 have a 7-bit serial address. The four MSBs of this address for the AD7416 are set to 1001, the AD7417 are 0101, while the three LSBs can be set by the user by connecting the A2 to A0 pins to either +V<sub>S</sub> or GND. By giving them different addresses, up to eight AD7416/AD7417s can be connected to a single serial bus, or the addresses can be set to avoid conflicts with other devices on the bus. The four MSBs of this address for the AD7418 are 0101, while the three LSBs are all set to zero.

The serial bus protocol operates as follows:

1. The master initiates data transfer by establishing a START condition, defined as a high-to-low transition on the serial data line SDA while the serial clock line SCL remains high. This indicates that an address/data stream will follow. All slave peripherals connected to the serial bus respond to the START condition, and shift in the next eight bits, consisting of a 7-bit address (MSB first) plus a R $\overline{\text{W}}$  bit, which determines the direction of the data transfer, i.e., whether data will be written to or read from the slave device.

The peripheral whose address corresponds to the transmitted address responds by pulling the data line low during the low period before the ninth clock pulse, known as the Acknowledge Bit. All other devices on the bus now remain idle while

the selected device waits for data to be read from or written to it. If the  $R/\overline{W}$  bit is a 0 then the master will write to the slave device. If the  $R/\overline{W}$  bit is a 1 the master will read from the slave device.

2. Data is sent over the serial bus in sequences of nine clock pulses, eight bits of data followed by an Acknowledge Bit from the receiver of data. Transitions on the data line must occur during the low period of the clock signal and remain stable during the high period, as a low-to-high transition when the clock is high may be interpreted as a STOP signal.
3. When all data bytes have been read or written, stop conditions are established. In WRITE mode, the master will pull the data line high during the 10th clock pulse to assert a STOP condition. In READ mode, the master device will pull the data line high during the low period before the 9th clock pulse. This is known as No Acknowledge. The master will then take the data line low during the low period before the 10th clock pulse, then high during the 10th clock pulse to assert a STOP condition.

Any number of bytes of data may be transferred over the serial bus in one operation, but it is not possible to mix read and write in one operation, because the type of operation is determined at the beginning and cannot subsequently be changed without starting a new operation.

### WRITING TO THE AD7416/AD7417/AD7418

Depending on the register being written to, there are three different writes for the AD7416/AD7417/AD7418.

1. Writing to the Address Pointer Register for a subsequent read.

In order to read data from a particular register, the Address Pointer Register must contain the address of that register. If it does not, the correct address must be written to the Address Pointer register by performing a single-byte write operation, as shown in Figure 7. The write operation consists of the serial bus address followed by the address pointer byte. No data is written to any of the data registers.

2. Writing a single byte of data to the Configuration Registers or  $T_{OTI}$ ,  $T_{HYST}$  Registers.

The Configuration Register is an 8-bit register, so only one byte of data can be written to it. If only 8-bit temperature comparisons are required, the temperature LSB can be ignored in  $T_{OTI}$  and  $T_{HYST}$ , and only eight bits need be written to the  $T_{OTI}$  and  $T_{HYST}$  registers.

Writing a single byte of data to one of these registers consists of the serial bus address, the data register address, written to the Address Pointer Register, followed by the data byte, written to the selected data register. This is illustrated in Figure 8.

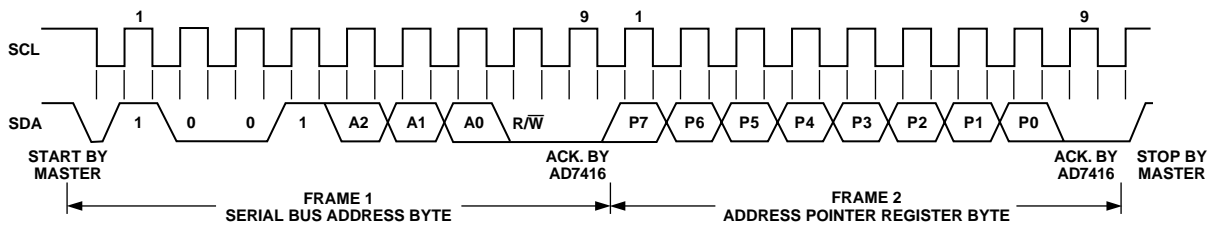

Figure 7. Writing to the Address Pointer Register to Select a Data Register for a Subsequent Read Operation

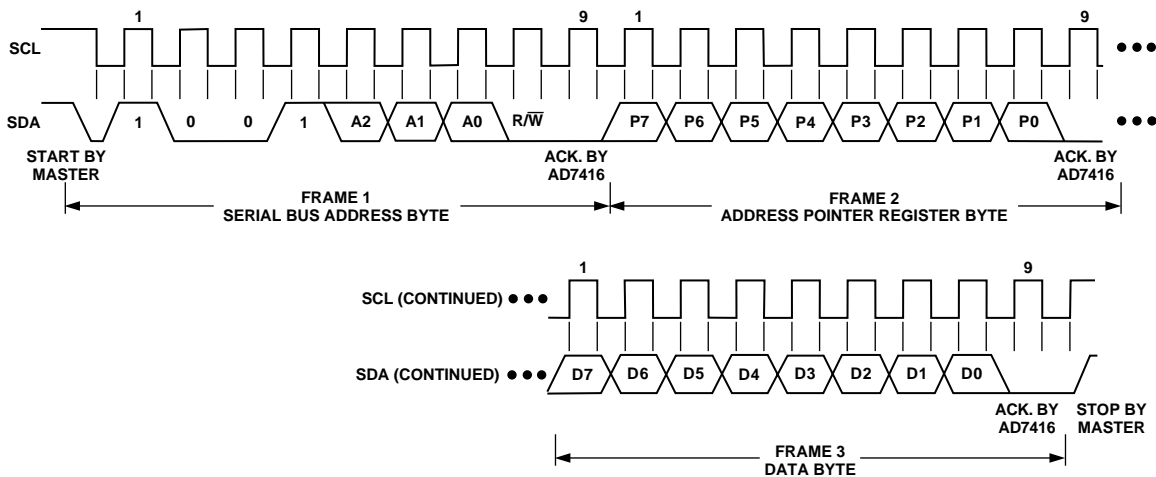

Figure 8. Writing to the Address Pointer Register Followed by a Single Byte of Data to the Selected Data Register

# AD7416/AD7417/AD7418

## 3. Writing two bytes of data to the $T_{OTI}$ or $T_{HYST}$ Register.

If 9-bit resolution is required for the temperature setpoints, then two bytes of data must be written to the  $T_{OTI}$  and  $T_{HYST}$  registers. This consists of the serial bus address, the register address, written to the address pointer register, followed by two data bytes written to the selected data register. This is illustrated in Figure 9.

## READING DATA FROM THE AD7416/AD7417/AD7418

Reading data from the AD7416/AD7417/AD7418 is a one or two byte operation. Reading back the contents of the Configuration Register is a single byte read operation, as shown in Figure 10, the register address previously having been set by a single-byte write operation to the address pointer register.

Reading data from the temperature value,  $T_{OTI}$  or  $T_{HYST}$  registers is a two-byte operation, as shown in Figure 11. It is also possible to read the most significant bit of a 9-/10-bit register in this manner.

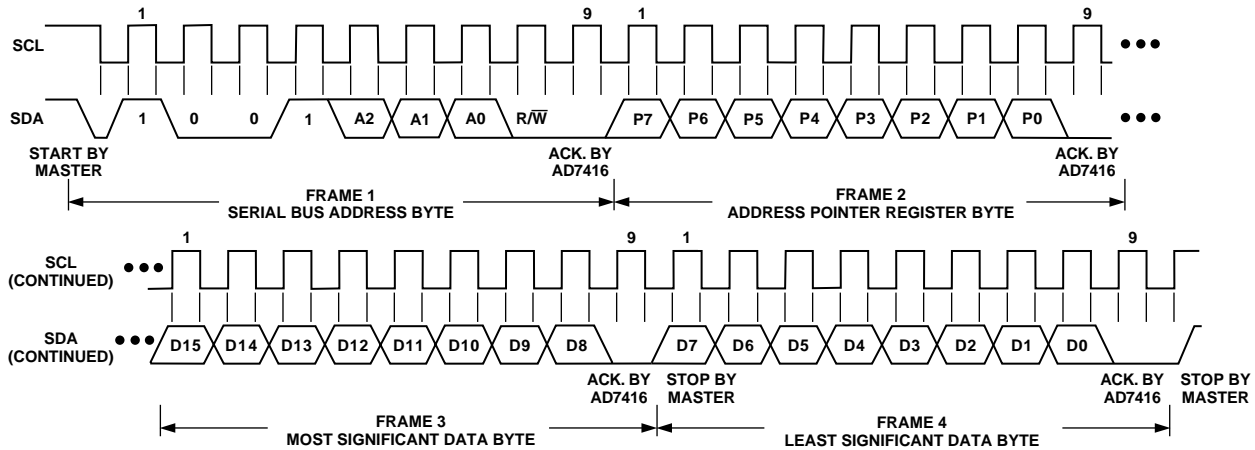

Figure 9. Writing to the Address Pointer Register Followed by a Two Bytes of Data to the  $T_{OTI}$  or  $T_{HYST}$  Register

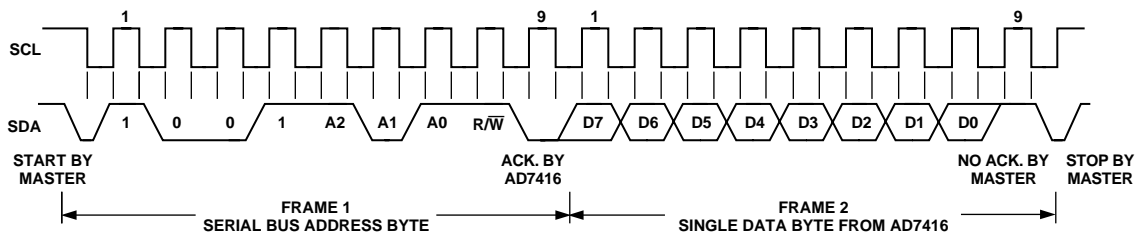

Figure 10. Reading a Single Byte of Data from the Configuration Register

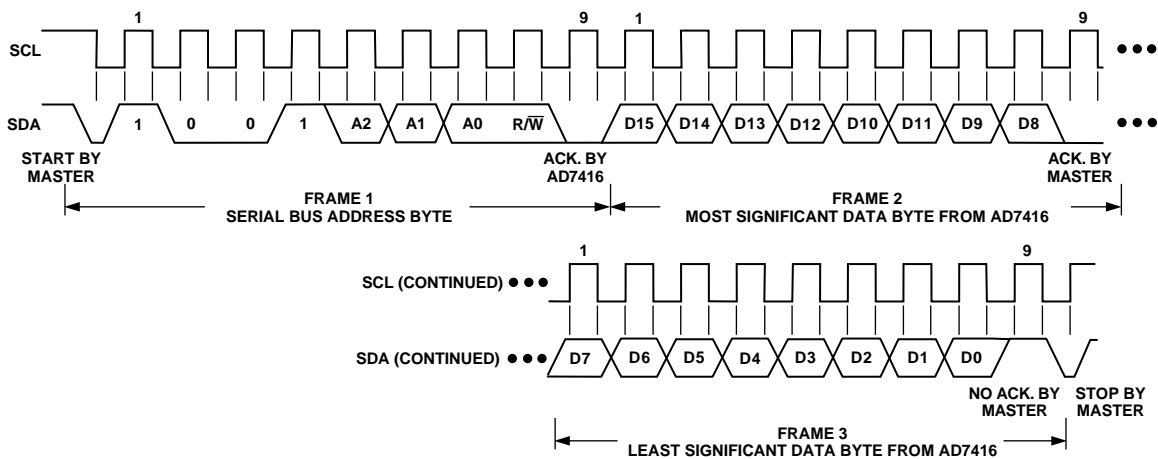

Figure 11. Reading Two Bytes of Data from  $T_{OTI}$  or  $T_{HYST}$  Register

## OTI OUTPUT

The OTI output has two operating modes, which are selected by Bit D1 of the Configuration Register. In the comparator mode, (D1 = 0), the OTI output becomes active when the temperature exceeds  $T_{OTI}$ , and remains active until the temperature falls below  $T_{HYST}$ . This mode allows the AD7416/AD7417/AD7418 to be used as a thermostat, for example to control the operation of a cooling fan.

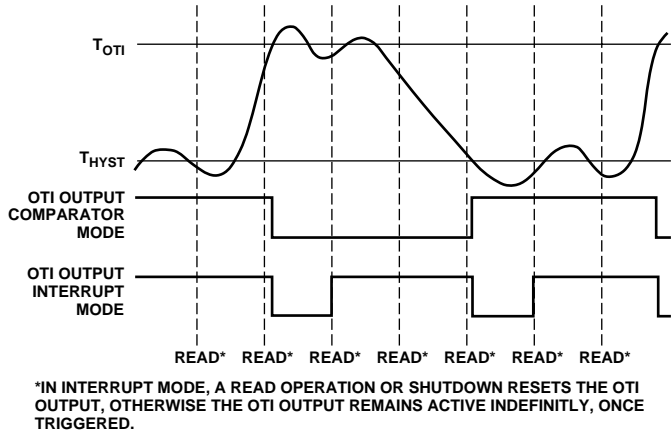

Figure 12. Operation of OTI Output (Shown Active Low)

The open-drain configuration of OTI allows the OTI outputs of several AD7416/AD7417/AD7418s to be wire-ANDed together when in active low mode.

The OTI output is used to indicate that an out-of-limit temperature excursion has occurred. OTI is an open-drain output that can be programmed to be active low by setting Bit D2 of the Configuration Register to 0, or active high by setting Bit D2 of the Configuration Register to 1.

In the Interrupt mode (D1 = 1), the OTI output becomes active when the temperature exceeds  $T_{OTI}$ , and remains active *even if the temperature falls below  $T_{HYST}$* , until it is reset by a read operation. Once OTI has become active by the temperature exceeding  $T_{OTI}$ , then been reset, it will remain inactive *even if the temperature remains, or subsequently rises again, above  $T_{OTI}$* . It will not become active again until the temperature falls below  $T_{HYST}$ . It will then remain active until reset by a read operation. Once OTI has become active by the temperature falling below  $T_{HYST}$ , then been reset, it will remain inactive *even if the temperature remains, or subsequently falls again, below  $T_{HYST}$* .

OTI is also reset when the AD7416/AD7417/AD7418 is placed in shutdown mode, by setting bit D0 of the Configuration Register to 1.

The OTI output requires an external pull-up resistor. This can be connected to a voltage different from  $+V_S$  (for example, to allow interfacing between 5 V and 3.3 V systems) provided that the maximum voltage rating of the OTI output is not exceeded.

The value of the pull-up resistor depends on the application, but should be as large as possible to avoid excessive sink currents at the OTI output, which can heat the chip and affect the temperature reading. The maximum value of pull-up resistor that will meet the output high current specification of the OTI output is 30 k $\Omega$ , but higher values may be used if a lower output current is required. For most applications a value of 10 k $\Omega$  will prove suitable.

## FAULT QUEUE

To avoid false triggering of the AD7416/AD7417/AD7418 in noisy environments, a fault queue counter is provided, which can be programmed by Bits D3 and D4 of the Configuration Register (see Table V) to count 1, 2, 4 or 6 fault events before OTI becomes active. In order to trigger OTI, the faults must occur consecutively. For example, if the fault queue is set to 4, then four consecutive temperature measurements greater than  $T_{OTI}$  (or less than  $T_{HYST}$ ) must occur. Any reading that breaks the sequence will reset the fault queue counter, so if there are three readings greater than  $T_{OTI}$  followed by a reading less than  $T_{OTI}$ , the fault queue counter will be reset without triggering OTI.

## POWER-ON DEFAULTS

The AD7416/AD7417/AD7418 always powers up with the following defaults:

Address pointer pointing to Temperature Value Register  
Comparator mode:

$T_{OTI} = 80^{\circ}\text{C}$   
 $T_{HYST} = 75^{\circ}\text{C}$   
OTI Active LOW  
Fault Queue = 1

These default settings allow the AD7416/AD7417/AD7418 to be used as a stand-alone thermostat without any connection to a serial bus.

## OPERATING MODES

The AD7416/AD7417/AD7418 has two possible modes of operation depending on the value of D0 in the Configuration Register.

### Mode 1

Normal operation of the AD7416/AD7417/AD7418 occurs when  $D0 = 0$ . In this active mode, a conversion takes place every 400  $\mu\text{s}$ . Once the conversion has taken place, the part partially powers down, consuming typically 350  $\mu\text{A}$  of current until the next conversion occurs.

Two situations can arise in this mode on the request of a temperature read. If a read occurs during a conversion, the conversion aborts and a new one starts on the Stop/Repeat start condition. The temperature value that is read is that of the previous completed conversion. The next conversion will typically occur 400  $\mu\text{s}$  after the new conversion has begun.

If a read is called between conversions, a conversion is initiated on the stop/repeat start condition. After this conversion, the part returns to performing a conversion every 400  $\mu\text{s}$ .

With a  $V_{DD} = 3\text{ V}$ , for each 400  $\mu\text{s}$  cycle, the AD7416 spends 40  $\mu\text{s}$  (or 10% of the time) in conversion mode. It spends 360  $\mu\text{s}$  (or 90% of time) in partial power-down mode. Thus the average power dissipated by the AD7416/AD7417/AD7418 is:

$$3\text{ mW} \times 0.1 + 1\text{ mW} \times 0.9 = 1.2\text{ mW}$$

### Mode 2

For applications where temperature measurements are required at a slower rate e.g., every second, power consumption of the part can be reduced by writing to the part to go to a full power-down between reads. The current consumption in full power-down is typically 0.2  $\mu\text{A}$  and full power-down is initiated when  $D0 = 1$  in the configuration register. When a measurement is required, a write operation can be performed to power-up the

# AD7416/AD7417/AD7418

part. The part then performs a conversion and is returned to power-down. The temperature value can be read in the full power-down because the I<sup>2</sup>C bus is continuously active.

The power dissipation in this mode depends on the rate at which reads take place. Taking the requirements for a temperature measurement every 100 ms as an example, the optimum power dissipation is achieved by placing the part in full power-down, waking it up every 100 ms, letting it operate for 400 μs and putting it into full power-down again. In this case the average power consumption is calculated as follows. The part spends 40 μs (or 0.04% of time) converting with 3 mW dissipation, and a 99.96 ms (99.96% of time) in full shutdown with 60 nW dissipation. Thus the average power dissipation is:

$$3 \text{ mW} \times 0.004 + 60 \text{ nW} \times 0.9996 = 1.2 \text{ μW}$$

The fastest throughput rate at which the AD7416/AD7417/AD7418 can be operated is 2.5 kHz (i.e., a read every 400 μs conversion period). Since T<sub>OTI</sub> and T<sub>HYST</sub> are two byte reads, the read time with the I<sup>2</sup>C operating at 100 kbit/s would be 270 μs. If temperature reads are called too often, reads will overlap with conversions, aborting them continuously, which results in invalid readings.

## CONVERT START MODE

The AD7417/AD7418 has an extra mode, set by writing to the MSB of the Config2 Register.

### CONVST Mode

By setting the CONVST mode bit to 1, conversions are initiated only by using the CONVST pin. When the AD7417/AD7418 is in this CONVST mode, there are two possible methods of operation, depending on the status of the CONVST line at the end of conversion.

If the CONVST line is high at the end of a conversion, the AD7417/AD7418 remains powered up at the end of a conversion and the next conversion is initiated and the track/hold goes into hold mode on the next falling edge of CONVST. The part never powers down provided the D0 bit of the configuration register remains at 0. In this method of operation, CONVST is normally high with a low-going pulse controlling the track/hold and conversion starts.

The second method is where the CONVST input is low at the end of conversion. When this happens, the part automatically enters its power-down mode at the end of conversion. The next rising edge of CONVST starts the power-up time. This power-up time is 4 μs. If the CONVST high time is longer than 4 μs, a conversion is initiated on the falling edge of CONVST and the track/hold also enters its hold mode at this time. If the CONVST high time is less than 4 μs, an internal timer, initiated by the rising edge of CONVST holds of the track/hold and the initiation of conversion until timer times out (4 μs after the rising edge of CONVST, which corresponds with the power-up time). In this method of operation, CONVST is normally low with a high-going pulse controlling the power-up and conversion starts.

The CONVST pin should not be pulsed when reading from or writing to the port. When performing temperature conversions, a minimum of 40 μs should be left between any two CONVST pulses to allow temperature conversions to complete before starting another.

## APPLICATIONS INFORMATION

### SUPPLY DECOUPLING

The AD7416/AD7417/AD7418 should be decoupled with a 0.1 μF ceramic capacitor between +V<sub>S</sub> and GND. This is particularly important if the part is mounted remote from the power supply.

### MOUNTING THE AD7416

The AD7416/AD7417/AD7418 can be used for surface or air-temperature sensing applications. If the device is cemented to a surface with thermally conductive adhesive, the die temperature will be within about 0.2°C of the surface temperature, thanks to the device's low power consumption. Care should be taken to insulate the back and leads of the device from the air, if the ambient air temperature is different from the surface temperature being measured.

The ground pin provides the best thermal path to the die, so the temperature of the die will be close to that of the printed circuit ground track. Care should be taken to ensure that this is in good thermal contact with the surface being measured.

As with any IC, the AD7416/AD7417/AD7418 and its associated wiring and circuits must be kept free from moisture to prevent leakage and corrosion, particularly in cold conditions where condensation is more likely to occur. Water resistant varnishes and conformal coatings can be used for protection. The small size of the AD7416 package allows it to be mounted inside sealed metal probes, which provide a safe environment for the device.

### FAN CONTROLLER

Figure 13 shows a simple fan controller that will switch on a cooling fan when the temperature exceeds 80°C, and switch it off again when the temperature falls below 75°C. The AD7416 can be used stand-alone in this application, or with a serial bus interface if different trip temperatures are required. If the AD7416 is used with a bus interface, the sense of OTI can be set to active high, Q1 and R1 can be omitted, and OTI connected directly to the gate of Q2, with R2 as the pull-up resistor.

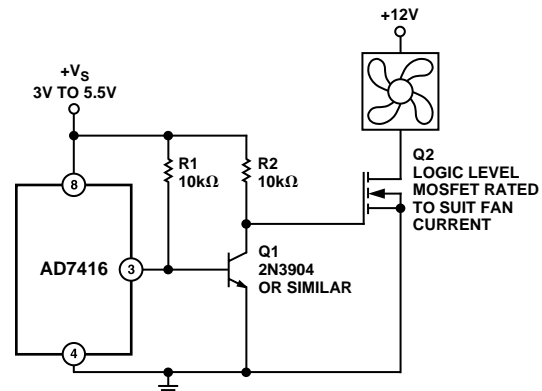

Figure 13. AD7416 Used as a Fan Controller

## THERMOSTAT

Figure 14 shows the AD7416 used as a thermostat. The heater will be switched on when the temperature falls below  $T_{HYST}$ , and switched off again when the temperature rises above  $T_{OS}$ . For this application, the OTI output should be programmed active low, and for comparator mode.

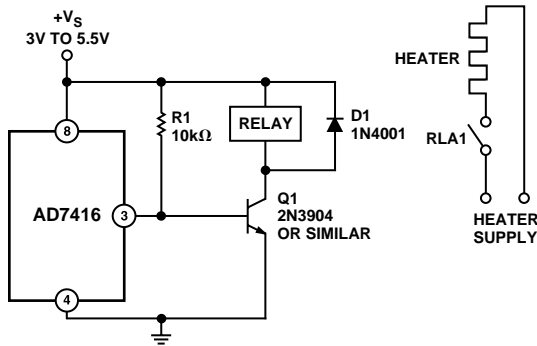

Figure 14. AD7416 Used as a Thermostat

## SYSTEM WITH MULTIPLE AD7416s

The three LSBs of the AD7416's serial address can be set by the user, allowing eight different addresses from 1001000 to 1001111. Figure 15 shows a system in which eight AD7416s are connected to a single serial bus, with their OTI outputs wire ANDed together to form a common interrupt line. This arrangement does mean that each device must be read to determine which one has generated the interrupt, and if a unique interrupt is required for each device, the OTI outputs can be connected separately to the I/O chip.

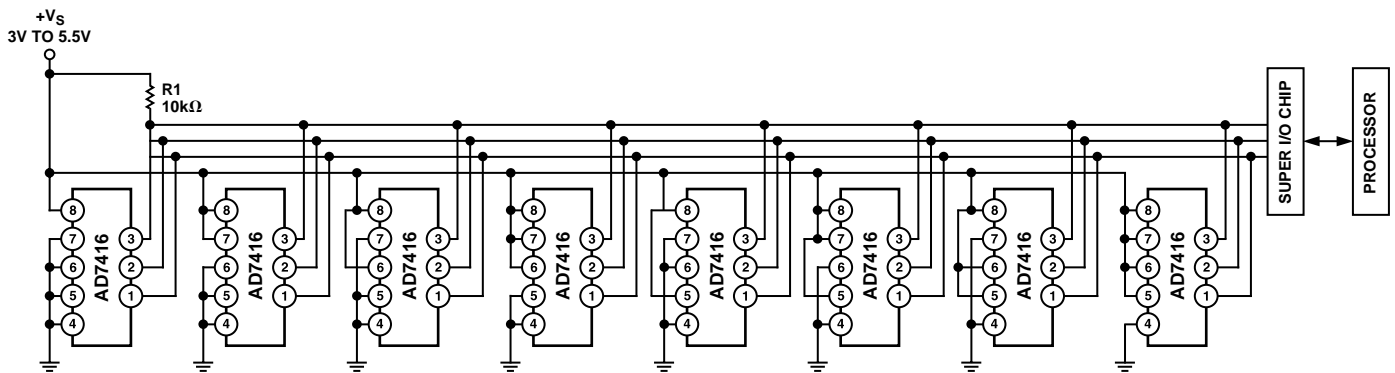

Figure 15. Multiple Connection of AD7416s to a Single Serial Bus

# AD7416/AD7417/AD7418

## OUTLINE DIMENSIONS

Dimensions shown in inches and (mm).

**16-Lead Narrow Body (SOIC)  
(R-16A)**

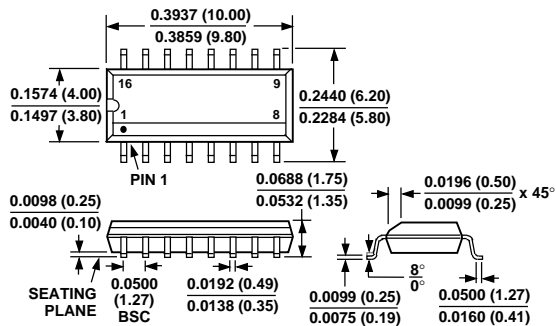

**16-Lead Thin Shrink Small Outline Package  
(TSSOP) (RU-16)**

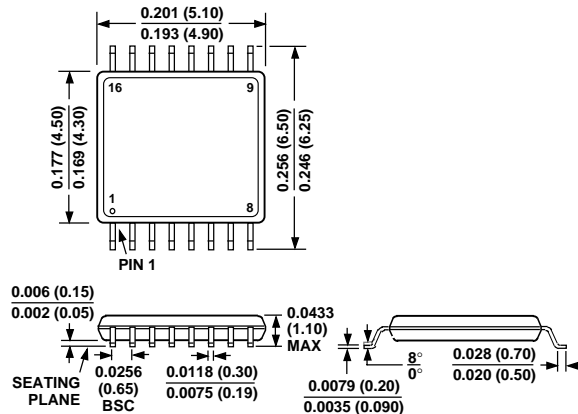

**8-Lead Narrow Body (SOIC)  
(SO-8)**

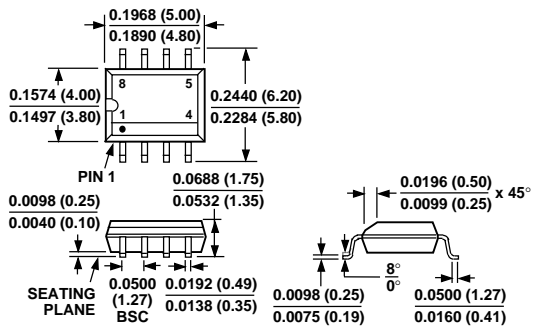

**8-Lead  $\mu$ SOIC Package  
(RM-8)**

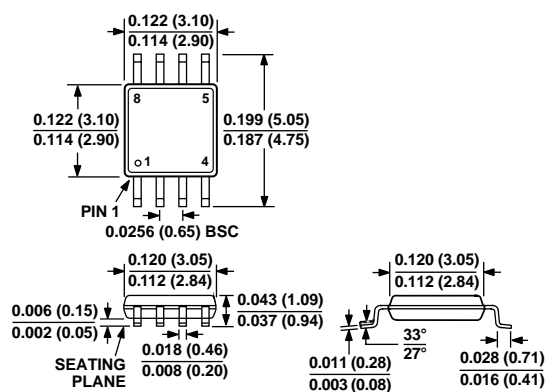

C3449-0-9/99

PRINTED IN U.S.A.